

OV9284 1-megapixel product brief

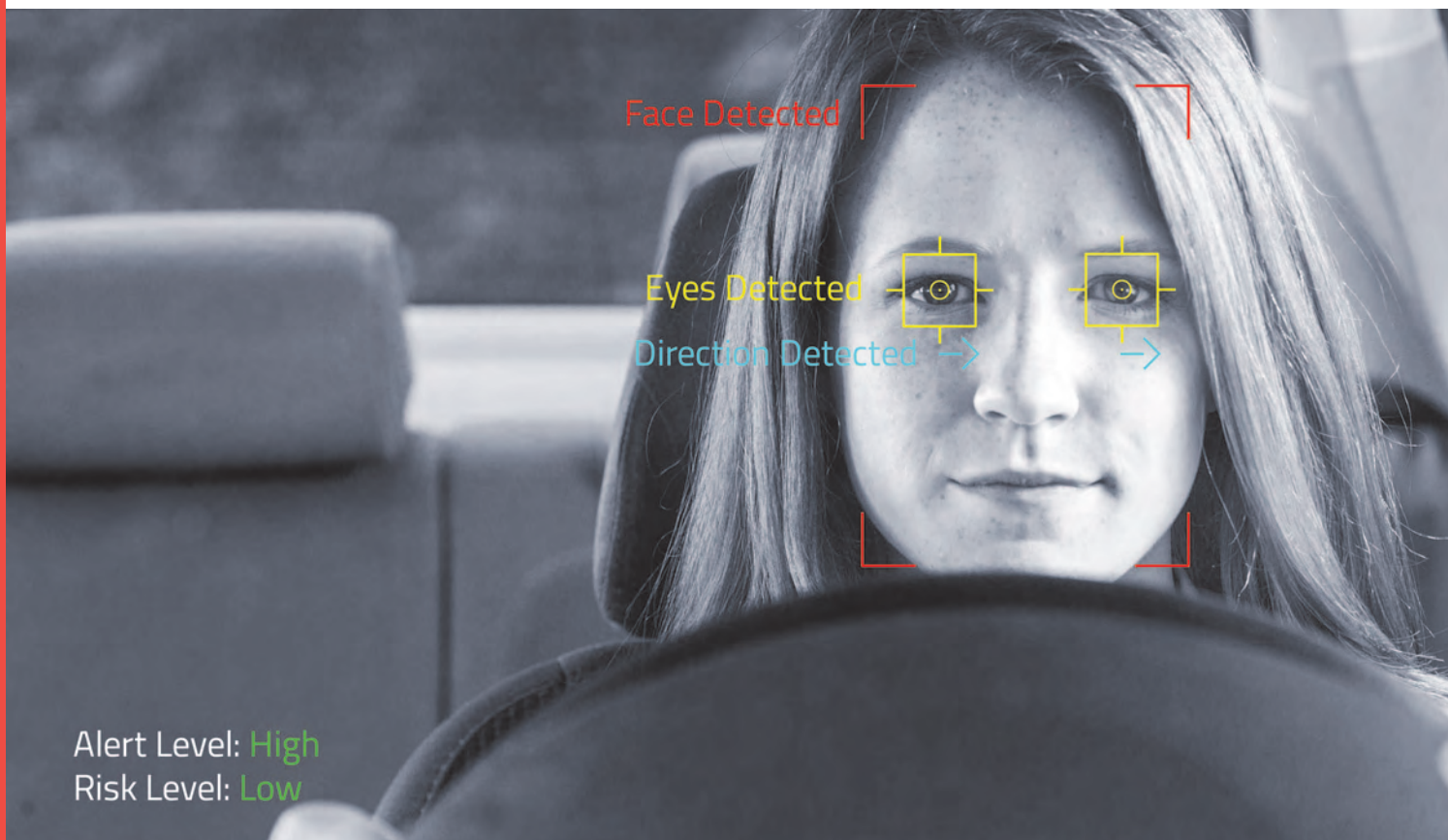

Alert Level: **High**
Risk Level: **Low**

Cost-Effective 1MP, High-Speed Global Shutter Image Sensor for Driver and Passenger Monitoring in Mainstream Vehicles



available in
a lead-free
package

Omnivision's OV9284 is a 1-megapixel global shutter image sensor that is ideal for in-cabin camera modules in passenger vehicles, where driver state monitoring (DSM) and passenger-monitoring cameras need to be extremely small and unobtrusive, while complying with new, stringent safety regulations. Semiautonomous vehicles use DSM to track the driver's eye gaze and allow the vehicle to take control when the driver becomes drowsy or distracted. The OV9284 is the industry's first image sensor with the right balance of cost effectiveness, high-quality imaging and advanced features to meet the needs for incorporating DSM in the mainstream automotive market.

The OV9284 also offers the industry's best near-infrared (NIR) quantum efficiency (QE) in a driver-monitoring image sensor, with 12% at 940 nm, which allows designers to achieve sufficient illumination with

fewer LEDs, thus reducing total system cost and power consumption. This sensor consumes only 90 mW of power at 60 frames per second (fps), which is 30% lower than the nearest competitor. Additionally, the high-speed global shutter sensor with OmniPixel®3-GS technology offers 1280 x 800 resolution at video speeds of up to 120 fps.

This sensor comes in a compact automotive chip-scale package (a-CSP™), which measures 5237 μm x 4463 μm for smaller lens designs. Its 27-degree chief ray angle enables a wider viewing angle in a thinner package, allowing for greater flexibility with camera design and placement.

Find out more at www.ovt.com.



Omnivision

Applications

- Driver Monitoring Systems
- Industrial Bar Code Scanning

Product Features

- 3 μm x 3 μm pixel with OmniPixel³-GS technology
- automatic black level calibration (ABLC)
- programmable controls for:
 - frame rate
 - mirror and flip
 - cropping
 - windowing
- support output formats: 8/10-bit RAW
- fast mode switching
- supports 2x2 monochrome binning
- two-lane MIPI serial output interface
- DVP parallel output interface
- supports horizontal and vertical 2:1 and 4:1 monochrome subsampling
- support for image sizes:
 - 1280 x 800
 - 1280 x 720
 - 640 x 480
 - 640 x 400
- embedded 256 bits of one-time programmable (OTP) memory for part identification
- two on-chip phase lock loops (PLLs)
- LED PWM
- built-in strobe control

OV9284



Ordering Information

- OV09284-E64Y-1A-Z (B&W, lead-free) 64-pin a-CSP™

Product Specifications

- active array size: 1296 x 816
- power supply:
 - analog: 2.8V (nominal)
 - core: 1.2V (nominal)
 - I/O: 1.8V (nominal)
- power requirements:
 - active: 156 mW
 - standby: 150 μA
 - XSHUTDOWN: 150 μA
- temperature range:
 - operating: -40°C to +105°C sensor ambient temperature and -40°C to +125°C junction temperature
- output interfaces: 2-lane MIPI serial output and DVP parallel output
- output formats: 8/10-bit RAW
- lens size: 1/4"
- input clock frequency: 6 - 27 MHz
- lens chief ray angle: 26.78° non-linear
- max S/N ratio: 38 dB
- dynamic range: 68 dB
- maximum image transfer rate:
 - 1280 x 800: 120 fps
- sensitivity:
 - 13000 mV/ $\mu\text{W}\cdot\text{cm}^2\cdot\text{sec}$ @ 850 nm
 - 6100 mV/ $\mu\text{W}\cdot\text{cm}^2\cdot\text{sec}$ @ 940 nm
- scan mode: progressive
- minimum exposure time: 1 row period
- maximum exposure time:
 - frame length - 25 row periods, where frame length is set by registers {0x380E, 0x380F}
- pixel size: 3 μm x 3 μm
- image area: 3896 μm x 2453 μm
- package dimensions:
 - a-CSP™: 5237 μm x 4463 μm

Functional Block Diagram

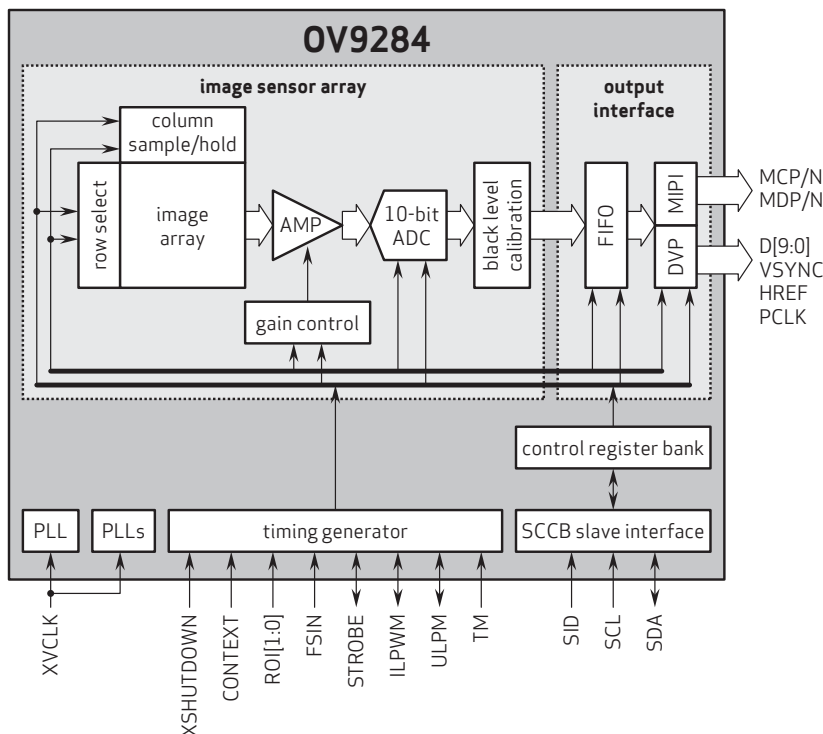

4275 Burton Drive
Santa Clara, CA 95054
USA

Tel: +1 408 567 3000
Fax: +1 408 567 3001
www.ovt.com

OmniVision reserves the right to make changes to their products or to discontinue any product or service without further notice. OmniVision, the OmniVision logo and OmniPixel are registered trademarks of OmniVision Technologies, Inc. a-CSP is a trademark of OmniVision Technologies, Inc. All other trademarks are the property of their respective owners.



OmniVision