



# 3.3V PROGRAMMABLE SKEW PLL CLOCK DRIVER TURBOCLOCK™ II PLUS

IDT5V996

## FEATURES:

- 3.3V operation
- 4 pairs of programmable skew outputs
- Low skew: 150ps same pair, 350ps all outputs
- Selectable positive or negative edge synchronization:  
Excellent for DSP applications
- Synchronous output enable
- Input frequency: 25MHz to 225MHz
- Output frequency: 25MHz to 225MHz
- 2x, 4x, 1/2, and 1/4 outputs (of VCO frequency)
- 3-level inputs for skew control
- PLL bypass for DC testing
- External feedback, internal loop filter
- 12mA balanced drive outputs
- Low Jitter: <150ps peak-to-peak
- Available in 144-pin BGA package

## DESCRIPTION:

The IDT5V996 is a high fanout PLL based clock driver intended for high performance computing and data-communication applications. The IDT5V996 has eight programmable skew outputs organized in four banks of two. Skew is controlled by 3-level input signals that may be hard wired to appropriate HIGH-MID-LOW levels. The IDT5V996 provides up to 18 programmable levels of output skew, prescaling, and other features.

Other features of IDT5V996 are synchronous output enable (G), TEST, and lock detect indicator (LOCK). When G is held low, all the outputs are synchronously enabled, however, if G is held high, all outputs except 3Q0 and 3Q1 are in the state designated by SE (HIGH or LOW).

When TEST is held low, the chip operates in normal condition. When held high, the PLL is shut off and the chip functions as a buffer. The lock detect indicator asserts high when the phase lock loop has acquired lock. During acquisition, the indicator is in the low state. Once the PLL has reached the steady-state condition within a specified frequency range, LOCK is asserted high.

The PLL is closed externally to provide more flexibility by allowing the user to control the delay between the input clock and the outputs. The IDT5V996 has LVTTTL outputs with 12mA balanced drive outputs.

The IDT5V996 is characterized for operation from -40°C to +85°C.

## FUNCTIONAL BLOCK DIAGRAM

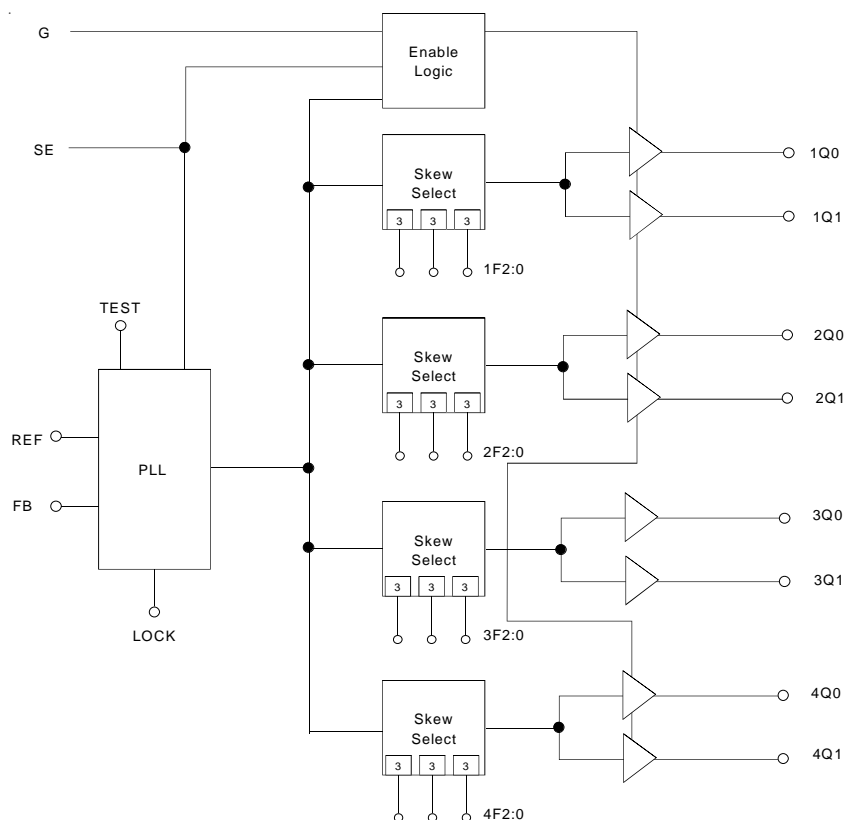

The IDT logo is a registered trademark of Integrated Device Technology, Inc.

INDUSTRIAL TEMPERATURE RANGE

DECEMBER 2001

PIN CONFIGURATION

|   | 1    | 2    | 3    | 4   | 5   | 6    | 7   | 8   | 9   | 10   | 11   | 12   |   |
|---|------|------|------|-----|-----|------|-----|-----|-----|------|------|------|---|
| A | VDDQ | VDDQ | VDDQ | GND | GND | LOCK | GND | GND | GND | VDDQ | VDDQ | VDDQ | A |
| B | VDDQ | VDDQ | VDDQ | GND | 2Q1 | 2Q0  | 1Q1 | 1Q0 | GND | VDDQ | VDDQ | VDDQ | B |
| C | VDDQ | VDDQ | VDD  | VDD | VDD | VDD  | VDD | VDD | VDD | VDD  | VDDQ | VDDQ | C |
| D | VDDQ | VDDQ | VDD  | GND | GND | GND  | GND | GND | GND | VDD  | 2F2  | 2F1  | D |
| E | VDDQ | G    | VDD  | GND | GND | GND  | GND | GND | GND | VDD  | 2F0  | 1F2  | E |
| F | TEST | REF  | VDD  | GND | GND | GND  | GND | GND | GND | VDD  | 1F1  | 1F0  | F |
| G | VDDQ | FB   | VDD  | GND | GND | GND  | GND | GND | GND | VDD  | 4F1  | 4F0  | G |
| H | VDDQ | SE   | VDD  | GND | GND | GND  | GND | GND | GND | VDD  | 3F0  | 4F2  | H |
| J | VDDQ | VDDQ | VDD  | GND | GND | GND  | GND | GND | GND | VDD  | 3F2  | 3F1  | J |
| K | VDDQ | VDDQ | VDD  | VDD | VDD | VDD  | VDD | VDD | VDD | VDD  | VDDQ | VDDQ | K |
| L | VDDQ | VDDQ | VDDQ | GND | 3Q1 | 3Q0  | 4Q1 | 4Q0 | GND | VDDQ | VDDQ | VDDQ | L |
| M | VDDQ | VDDQ | VDDQ | GND | GND | GND  | GND | GND | GND | VDDQ | VDDQ | VDDQ | M |
|   | 1    | 2    | 3    | 4   | 5   | 6    | 7   | 8   | 9   | 10   | 11   | 12   |   |

BGA  
TOP VIEW

ABSOLUTE MAXIMUM RATINGS<sup>(1)</sup>

| Symbol                                                   | Description                                                  | Max                            | Unit |
|----------------------------------------------------------|--------------------------------------------------------------|--------------------------------|------|
| V <sub>DDQ</sub> , V <sub>DD</sub>                       | Supply Voltage Range                                         | -0.5 to +4.6                   | V    |
| V <sub>I</sub> <sup>(2)</sup>                            | Input Voltage Range                                          | -0.5 to 4.6                    | V    |
| V <sub>O</sub> <sup>(2)</sup>                            | Voltage range applied to any output in the high or low state | -0.5 to V <sub>DDQ</sub> + 0.5 | V    |
| I <sub>IK</sub> (V <sub>I</sub> < 0)                     | Input Clamp Current                                          | -50                            | mA   |
| I <sub>O</sub> (V <sub>O</sub> = 0 to V <sub>DDQ</sub> ) | Continuous Output Current                                    | ±50                            | mA   |
| V <sub>DDQ</sub> or GND                                  | Continuous Current                                           | ±100                           | mA   |
| T <sub>STG</sub>                                         | Storage Temperature Range                                    | -65 to +150                    | °C   |

## NOTES:

- Stresses beyond those listed under ABSOLUTE MAXIMUM RATINGS may cause permanent damage to the device. These are stress ratings only, and functional operation of the device at these or any other conditions above those indicated in the operational sections of this specification is not implied. Exposure to absolute-maximum-rated conditions for extended periods may affect device reliability.
- The input and output negative-voltage ratings may be exceeded if the input and output clamp-current ratings are observed.

CAPACITANCE<sup>(1,2)</sup> (T<sub>A</sub> = +25°C, f = 1MHz, V<sub>IN</sub> = 0V)

| Parameter       | Description                                                   | Min | Typ. | Max. | Unit |
|-----------------|---------------------------------------------------------------|-----|------|------|------|
| C <sub>IN</sub> | Input Capacitance<br>V <sub>I</sub> = V <sub>DDQ</sub> or GND | —   | 8    | —    | pF   |

## NOTES:

- Unused inputs must be held high or low to prevent them from floating.
- Capacitance applies to all inputs except nF<sub>2:0</sub>. This value is characterized but not production tested.

## PIN DESCRIPTION

| Pin Name            | Type | Description                                                                                                                                                                                                                                                                                                                                                                  |
|---------------------|------|------------------------------------------------------------------------------------------------------------------------------------------------------------------------------------------------------------------------------------------------------------------------------------------------------------------------------------------------------------------------------|
| REF                 | IN   | Reference Clock Input                                                                                                                                                                                                                                                                                                                                                        |
| SE                  | IN   | Selectable positive or negative edge control. When LOW/HIGH, the outputs are synchronized with the negative/positive edge of the reference clock. When outputs are synchronously stopped with the G pin, SE determines the level at which outputs stop. When SE is LOW/HIGH, outputs synchronously stop HIGH/LOW.                                                            |
| FB                  | IN   | Feedback Input                                                                                                                                                                                                                                                                                                                                                               |
| G                   | IN   | Output gate for "true" nQ <sub>[1:0]</sub> outputs. When G is LOW, the "true" nQ <sub>[1:0]</sub> outputs are enabled. When G is HIGH, the "true" nQ <sub>[1:0]</sub> outputs are in the state designated by SE (HIGH or LOW) (except 3Q <sub>0</sub> and 3Q <sub>1</sub> ) - 3Q <sub>0</sub> and 3Q <sub>1</sub> may be used as the feedback signal to maintain phase lock. |
| TEST                | IN   | TEST = LOW means normal operation. TEST = HIGH means that the PLL is powered down and REF is routed to all the outputs. The skews selected with the nF <sub>[2:0]</sub> pins are still in effect. (The TEST pin is a TTL input.)                                                                                                                                             |
| nF <sub>[2:0]</sub> | IN   | 3-level inputs for selecting 1 of 18 skew taps or frequency functions                                                                                                                                                                                                                                                                                                        |
| nQ <sub>[1:0]</sub> | OUT  | Clock Output Pairs                                                                                                                                                                                                                                                                                                                                                           |
| V <sub>DDQ</sub>    | PWR  | Power supply for output buffers                                                                                                                                                                                                                                                                                                                                              |
| V <sub>DD</sub>     | PWR  | Power supply for phase locked loop and other internal circuitry                                                                                                                                                                                                                                                                                                              |
| GND                 | PWR  | Ground                                                                                                                                                                                                                                                                                                                                                                       |
| LOCK                | OUT  | Lock Detect. Asserted (HIGH) when the PLL is locked. The REF input must be oscillating.                                                                                                                                                                                                                                                                                      |

## PROGRAMMABLE SKEW

Output skew with respect to the REF input is adjustable to compensate for PCB trace delays, backplane propagation delays or to accommodate requirements for special timing relationships between clocked components. Skew is selectable as a multiple of a time unit (t<sub>u</sub>) which ranges from 278ps to 625ps (see Programmable Skew Range and Resolution Table). There are 16 skew configurations available for each output pair. These configurations are chosen by the nF<sub>2:0</sub> control pins. In order to

minimize the number of control pins, 3-level inputs (HIGH-MID-LOW) are used, they are intended for but not restricted to hard-wiring. Undriven 3-level inputs default to the MID level. Where programmable skew is not a requirement, the control pins can be left open for the zero skew default setting. The Control Summary Table shows how to select specific skew taps by using the nF<sub>2:0</sub> control pins.

## EXTERNAL FEEDBACK

By providing external feedback, the IDT5V996 gives users flexibility with regard to skew adjustment. The FB signal is compared with the input REF signal at the phase detector in order to drive the VCO. Phase differences cause the VCO of the PLL to adjust upwards or downwards accordingly.

An internal loop filter moderates the response of the VCO to the phase detector. The loop filter transfer function has been chosen to provide minimal jitter (or frequency variation) while still providing accurate responses to input frequency changes.

## PLL PROGRAMMABLE SKEW RANGE AND RESOLUTION TABLE

| Timing Unit Calculation (tu)                            | $1/(16 \times F_{NOM})$ | Comments        |
|---------------------------------------------------------|-------------------------|-----------------|
| VCO Frequency Range ( $F_{NOM}$ ) <sup>(1)</sup>        | 100 to 225 MHz          |                 |
| Skew Adjustment Range <sup>(2)</sup><br>Max Adjustment: | $\pm 4.375\text{ns}$    | ns              |
|                                                         | $\pm 157.5^\circ$       | Phase Degrees   |
|                                                         | $\pm 43.75\%$           | % of Cycle Time |
| Example 1, $F_{NOM} = 100\text{MHz}$                    | $t_u = 0.625\text{ns}$  | —               |
| Example 2, $F_{NOM} = 167\text{MHz}$                    | $t_u = 0.374\text{ns}$  | —               |
| Example 3, $F_{NOM} = 225\text{MHz}$                    | $t_u = 0.278\text{ns}$  | —               |

### NOTES:

- The VCO frequency always appears at nQ1:0 outputs when they are operated in their undivided modes. The frequency appearing at the REF and FB inputs will be  $F_{NOM}$  when the output connected to FB is undivided. The frequency of the REF and FB inputs will be  $F_{NOM}/2$  or  $F_{NOM}/4$  when the part is configured for frequency multiplication by using a divided output as the FB input. Using the nF[2:0] inputs allows a different method for frequency multiplication (see Control Summary Table for Feedback Signals).
- Skew adjustment range assumes that a zero skew output is used for feedback. If a skewed Q output is used for feedback, then adjustment range will be greater. For example if a  $4t_u$  skewed output is used for feedback, all other outputs will be skewed  $-4t_u$  in addition to whatever skew value is programmed for those outputs. 'Max adjustment' range applies to all output pairs where  $\pm 7t_u$  skew adjustment is possible and at the lowest  $F_{NOM}$  value.

## CONTROL SUMMARY TABLE FOR FEEDBACK SIGNALS<sup>(1)</sup>

| nF2 | nF1 | nF0 | Output Skew            |
|-----|-----|-----|------------------------|
| L   | L   | L   | Disable <sup>(2)</sup> |
| L   | H   | L   | -7tu                   |
| L   | H   | M   | -6tu                   |
| L   | H   | H   | -5tu                   |
| M   | L   | L   | -4tu                   |
| M   | L   | M   | -3tu                   |
| M   | L   | H   | -2tu                   |
| M   | M   | L   | -1tu                   |
| M   | M   | M   | Zero Skew              |
| M   | M   | H   | +1tu                   |
| M   | H   | L   | +2tu                   |
| M   | H   | M   | +3tu                   |
| M   | H   | H   | +4tu                   |
| H   | L   | L   | +5tu                   |
| H   | L   | M   | +6tu                   |
| H   | L   | H   | +7tu                   |
| H   | M   | L   | Inverted               |
| H   | M   | M   | Divide by 2            |
| H   | M   | H   | Divide by 4            |

### NOTES:

- All unused/unnoted combinations are reserved.
- When G is LOW, all output pairs are individually disabled to the level designated by SE. When SE is LOW/HIGH, output pairs disable HIGH/LOW.

## RECOMMENDED OPERATING RANGE

| Symbol                             | Description                   | Min. | Typ. | Max. | Unit |
|------------------------------------|-------------------------------|------|------|------|------|
| V <sub>DD</sub> / V <sub>DDQ</sub> | Power Supply Voltage          | 3    | 3.3  | 3.6  | V    |
| T <sub>A</sub>                     | Ambient Operating Temperature | -40  | +25  | +85  | °C   |

## DC ELECTRICAL CHARACTERISTICS OVER OPERATING RANGE

| Symbol           | Parameter                                      | Conditions                                                         | Min.                   | Max.                   | Unit |
|------------------|------------------------------------------------|--------------------------------------------------------------------|------------------------|------------------------|------|
| V <sub>IH</sub>  | Input HIGH Voltage                             | Guaranteed Logic HIGH (REF, FB Inputs Only)                        | 2                      | —                      | V    |
| V <sub>IL</sub>  | Input LOW Voltage                              | Guaranteed Logic LOW (REF, FB Inputs Only)                         | —                      | 0.8                    | V    |
| V <sub>IHH</sub> | Input HIGH Voltage Level <sup>(1)</sup>        | 3-Level Inputs Only                                                | V <sub>DD</sub> -0.6   | —                      | V    |
| V <sub>IMM</sub> | Input MID Voltage Level <sup>(1)</sup>         | 3-Level Inputs Only                                                | V <sub>DD</sub> /2-0.3 | V <sub>DD</sub> /2+0.3 | V    |
| V <sub>ILL</sub> | Input LOW Voltage Level <sup>(1)</sup>         | 3-Level Inputs Only                                                | —                      | 0.6                    | V    |
| I <sub>IN</sub>  | Input Leakage Current<br>(REF, FB Inputs Only) | V <sub>IN</sub> = V <sub>CC</sub> or GND<br>V <sub>CC</sub> = Max. | -5                     | +5                     | μA   |
| I <sub>3</sub>   | 3-Level Input DC Current (nF2:0)               | V <sub>IN</sub> = V <sub>DD</sub><br>HIGH Level                    | —                      | +200                   | μA   |
|                  |                                                | V <sub>IN</sub> = V <sub>DD</sub> /2<br>MID Level                  | -50                    | +50                    |      |
|                  |                                                | V <sub>IN</sub> = GND<br>LOW Level                                 | -200                   | —                      |      |
| V <sub>OH</sub>  | Output HIGH Voltage Level                      | V <sub>DD</sub> = Min., I <sub>OH</sub> = -12mA                    | 2.4                    | —                      | V    |
| V <sub>OL</sub>  | Output LOW Voltage Level                       | V <sub>DD</sub> = Min., I <sub>OL</sub> = 12mA                     | —                      | 0.4                    | V    |

**NOTE:**  
1. These inputs are normally wired to V<sub>DDQ</sub>, GND, or unconnected. Internal termination resistors bias unconnected inputs to V<sub>DDQ</sub>/2. If these inputs are switched, the function and timing of the outputs may be glitched, and the PLL may require an additional t<sub>LOCK</sub> time before all datasheet limits are achieved.

## POWER SUPPLY CHARACTERISTICS

| Symbol           | Parameter                               | Test Conditions <sup>(1)</sup>                                                                                             | Typ. <sup>(2)</sup> | Max. | Unit   |
|------------------|-----------------------------------------|----------------------------------------------------------------------------------------------------------------------------|---------------------|------|--------|
| I <sub>DDQ</sub> | Quiescent Power Supply Current          | V <sub>DDQ</sub> = Max., REF = FB = SE = G = LOW,<br>TEST = HIGH, All nF2:0 = HHM <sup>(3)</sup> ,<br>All outputs floating | —                   | 30   | mA     |
| I <sub>DD</sub>  | Dynamic Power Supply Current per Output | V <sub>DDQ</sub> = Max., C <sub>L</sub> = 0pF                                                                              | 410                 | 650  | μA/MHz |
| I <sub>TOT</sub> | Total Power Supply Current              | V <sub>DDQ</sub> = 3.3V, F <sub>VCO</sub> = 100MHz, C <sub>L</sub> = 20pF                                                  | 124                 | —    | mA     |
|                  |                                         | V <sub>DDQ</sub> = 3.3V, F <sub>VCO</sub> = 167MHz, C <sub>L</sub> = 20pF                                                  | 197                 | —    |        |
|                  |                                         | V <sub>DDQ</sub> = 3.3V, F <sub>VCO</sub> = 225MHz, C <sub>L</sub> = 20pF                                                  | 253                 | —    |        |

**NOTES:**  
1. Measurements are for divide-by-1 outputs.  
2. For nominal voltage and temperature.  
3. This configuration is only specific for I<sub>DDQ</sub> measurements.

## SWITCHING CHARACTERISTICS OVER OPERATING RANGE <sup>(1)</sup>

| Symbol               | Parameter                                                                     | Min.                                                 | Typ. | Max.  | Unit |
|----------------------|-------------------------------------------------------------------------------|------------------------------------------------------|------|-------|------|
| F <sub>NOM</sub>     | VCO Frequency Range                                                           | See PLL Programmable Skew Range and Resolution Table |      |       |      |
| F <sub>REF</sub>     | REF Clock Input Frequency                                                     | 25                                                   | —    | 225   | MHz  |
| t <sub>REF</sub>     | REF Clock Duty Cycle                                                          | 10                                                   | —    | 90    | %    |
| t <sub>u</sub>       | Programmable Skew Time Unit                                                   | See Control Summary Table                            |      |       |      |
| t <sub>SK(EPR)</sub> | Matched-Pair Skew (xQ <sub>0</sub> , xQ <sub>1</sub> ) <sup>(1,2,3)</sup>     | —                                                    | —    | 150   | ps   |
| t <sub>SK(O)</sub>   | Output Skew (Rise-Rise, Fall-Fall, Same Frequency and Phase) <sup>(1,2)</sup> | —                                                    | —    | 350   |      |
| t <sub>SK(ω)</sub>   | Multiple Frequency Skew <sup>(1,2)</sup>                                      | —                                                    | —    | 550   |      |
| t <sub>SK(INV)</sub> | Inverting Skew Between Nominal and Inverted <sup>(1,2,4)</sup>                | —                                                    | —    | 500   |      |
| t <sub>SK(EV)</sub>  | Output Skew (Rise-Fall, Inverted-Divided) <sup>(1,2)</sup>                    | —                                                    | —    | 500   |      |
| t <sub>SK(E4)</sub>  | Output Skew (Rise-Fall, Divided-Divided) <sup>(1,2,4)</sup>                   | —                                                    | —    | 500   |      |
| t <sub>DEV</sub>     | Device-to-Device Skew <sup>(2,5)</sup>                                        | —                                                    | —    | 250   |      |
| t <sub>φ</sub>       | REF Input to FB Static Phase Offset (V <sub>TH</sub> = V <sub>DDO</sub> /2)   | -250                                                 | —    | +250  | ns   |
| t <sub>ODCV</sub>    | Output Duty Cycle Variation from 50% <sup>(1,7)</sup>                         | -0.75                                                | —    | +0.75 |      |
| t <sub>R</sub>       | Output Rise Time (0.8V to 2V) <sup>(1)</sup>                                  | —                                                    | —    | 2.2   |      |
| t <sub>F</sub>       | Output Fall Time (2V to 0.8V) <sup>(1)</sup>                                  | —                                                    | —    | 2.2   | ms   |
| t <sub>LOCK</sub>    | PLL Lock Time <sup>(6)</sup>                                                  | —                                                    | —    | 0.5   |      |
| t <sub>j</sub>       | Cycle-to-Cycle Output Jitter, Peak-to-Peak <sup>(1)</sup>                     | —                                                    | —    | 150   | ps   |

### NOTES:

1. Measured at V<sub>TH</sub> = V<sub>DDO</sub>/2, output load C<sub>L</sub> = 20pF.
2. Skew is the time between the earliest and the latest output transition among all outputs for which the same t<sub>u</sub> delay has been selected when all are loaded with the specified load.
3. t<sub>SK(EPR)</sub> is the skew between a pair of outputs (xQ<sub>0</sub> and xQ<sub>1</sub>) when all eight outputs are selected for 0t<sub>u</sub>.
4. There are 3 classes of outputs: Nominal (multiple of t<sub>u</sub> delay), Inverted, and Divided (Divide-by-2 or Divide-by-4 mode).
5. t<sub>DEV</sub> is the output-to-output skew between any two devices operating under the same conditions (V<sub>DD</sub> and V<sub>DDO</sub>, ambient temperature, air flow, etc.)
6. t<sub>LOCK</sub> is the time that is required before synchronization is achieved. This specification is valid only after V<sub>DD</sub> and V<sub>DDO</sub> are stable and within normal operating limits. This parameter is measured from the application of a new signal or frequency at REF or FB until t<sub>PD</sub> is within specified limits.
7. t<sub>ODCV</sub> is measured with nF<sub>[2:0]</sub> = MMM.

## AC TEST LOADS AND WAVEFORMS

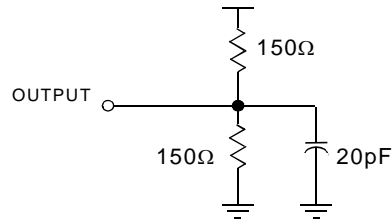

*AC Load*

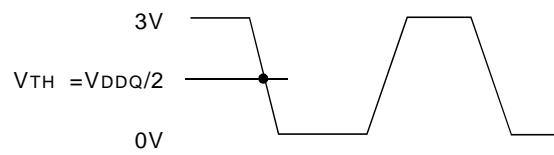

*Input Waveform*

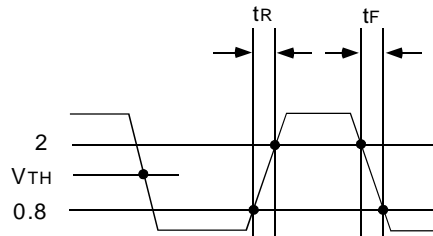

*Output Waveform*

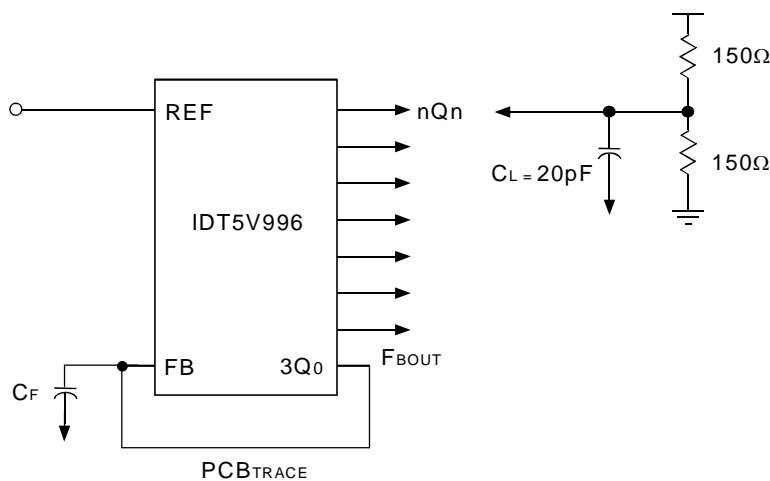

*Static Phase Offset and Skew Calculations (2,3)*

**NOTES:**

1.  $V_{TH} = V_{DDQ}/2$ .
2.  $C_F = C_L - C_{FBIN} - C_{PCBTRACE}$ ;  $C_{FBIN} \cong 6pF$
3. Calculations were done by adjusting the input slew rate to match with the output slew rate.

## AC TIMING DIAGRAM

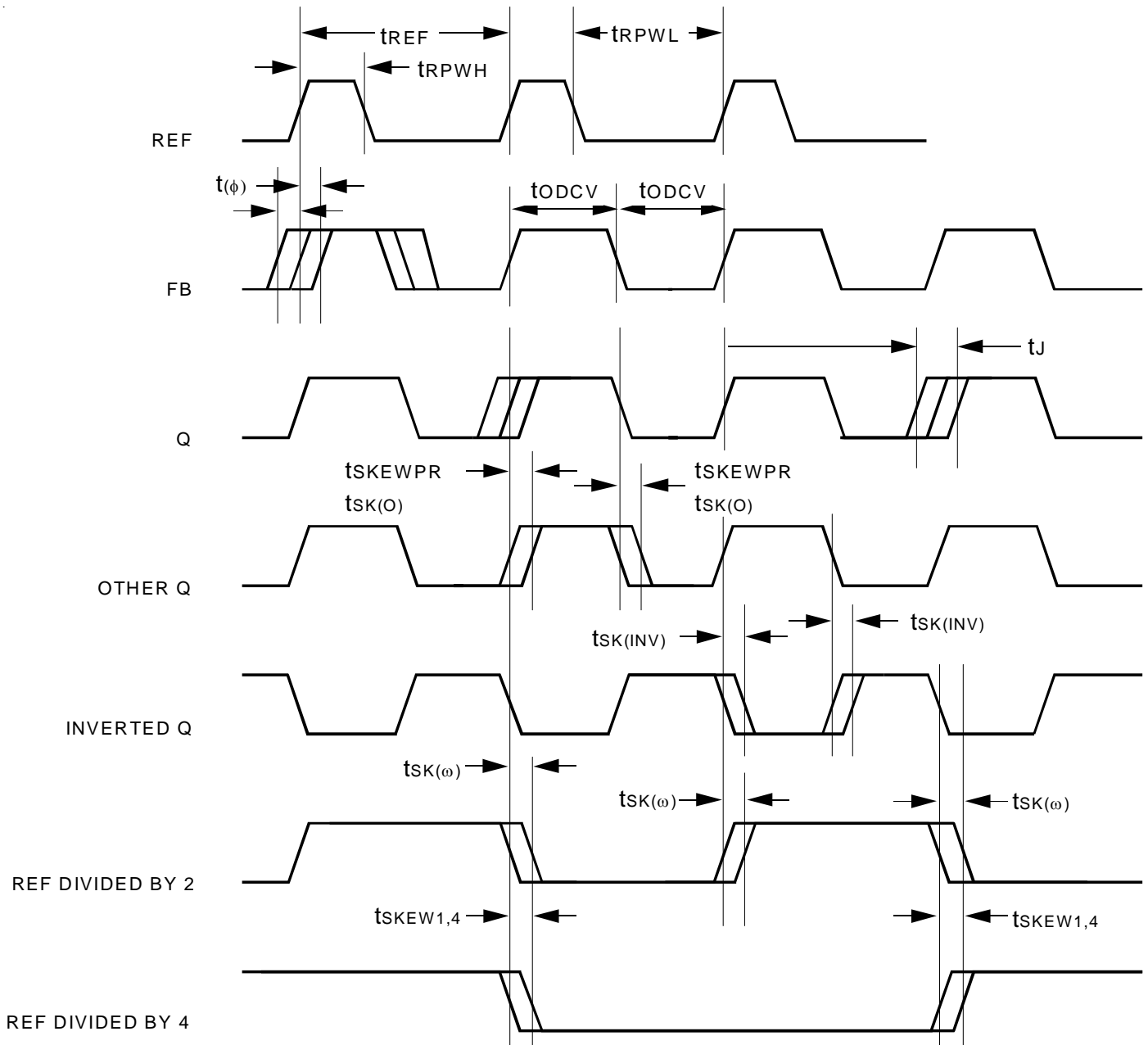

### NOTES:

SE: The AC Timing Diagram applies to SE=VDD. For SE=GND, the negative edge of FB aligns with the negative edge of REF, divided outputs change on the negative edge of REF, and the positive edges of the divide-by-2 and the divide-by-4 signals align.

Skew: The time between the earliest and the latest output transition among all outputs for which the same  $t_u$  delay has been selected when all are loaded with 20pF and terminated with 75Ω to VDD/2.

tSKEWPR: The skew between a pair of outputs (xQ0 and xQ1) when all eight outputs are selected for 0tu.

tSK(O): The skew between outputs when they are selected for 0tu.

tDEV: The output-to-output skew between any two devices operating under the same conditions (VDD, VDD, ambient temperature, air flow, etc.)

tODCV: The deviation of the output from a 50% duty cycle. Output pulse width variations are included in tSKEW1 and tSKEW4 specifications.

tSK(ω): The skew between outputs of different frequencies.

tSK(INV): The skew between inverting and non-inverting outputs.

tr and tf are measured between 0.8V and 2V.

tLOCK: The time that is required before synchronization is achieved. This specification is valid only after VDD/VDD is stable and within normal operating limits. This parameter is measured from the application of a new signal or frequency at REF or FB until tPD is within specified limits.



## ORDERING INFORMATION

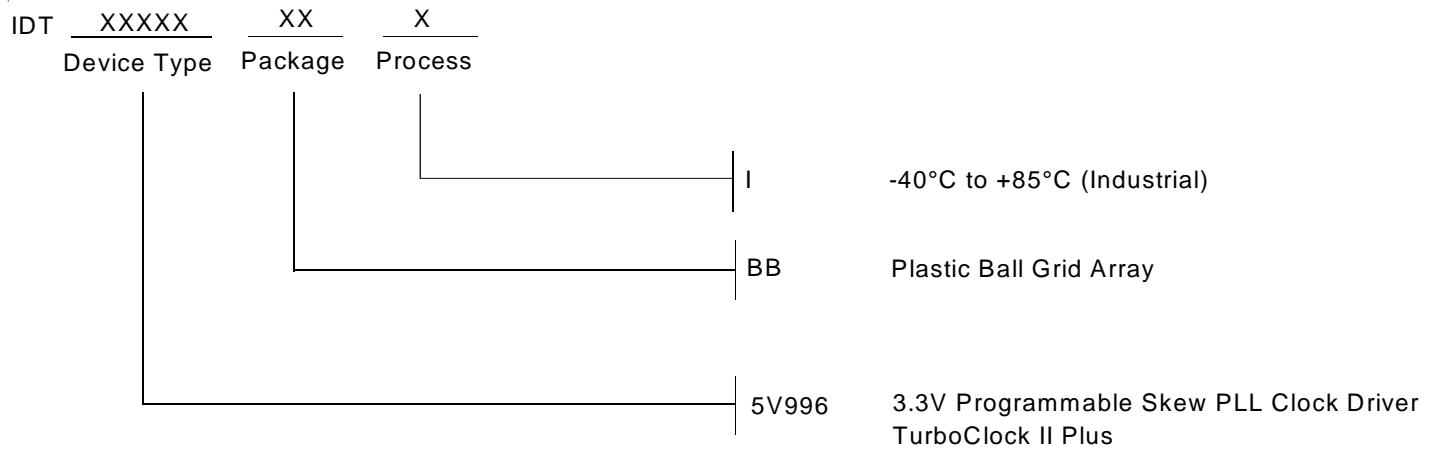

**CORPORATE HEADQUARTERS**  
2975 Stender Way  
Santa Clara, CA 95054

**for SALES:**  
800-345-7015 or 408-727-6116  
fax: 408-492-8674  
www.idt.com

**for Tech Support:**  
logichelp@idt.com  
(408) 654-6459