

SPECIFICATION	CONNECTION	UNIPOLAR	BIPOLAR (SERIAL)
AMPS/PHASE		0.31	0.22
RESISTANCE/PHASE(Ohms)@25°C		35.80±10%	77.00±10%
INDUCTANCE/PHASE(mH)@1KHz		36.00±20%	144.00±20%
HOLDING TORQUE(Nm)[lb-in]		0.16[1.42]	0.23[2.04]
STEP ANGLE(°)		0.90	
STEP ACCURACY(NON-ACCUM)		±5.00%	
ROTOR INERTIA(g-cm ²)		38.00	
WEIGHT(Kg)[lb]		0.28[0.62]	
TEMPERATURE RISE:MAX.80°C (MOTOR STANDSTILL;FOR 2PHASE ENERGIZED)			
AMBIENT TEMPERATURE -10°C~50°C[14°F~122°F]			
INSULATION RESISTANCE 100 Mohm (UNDER NORMAL TEMPERATURE AND HUMIDITY)			
INSULATION CLASS B 130°C[266°F]			
DIELECTRIC STRENGTH 500VAC FOR 1MIN.(BETWEEN THE MOTOR COILS AND THE MOTOR CASE)			
AMBIENT HUMIDITY MAX.85%(NO CONDENSATION)			

STEP	A	B	\bar{A}	\bar{B}	O(\bar{O})	CW
1	+	+			+	
2		+	+		+	
3			+	+	+	
4	+			+	+	
1	+	+			+	

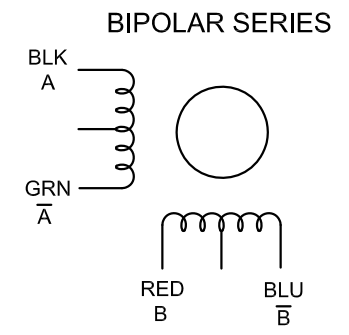
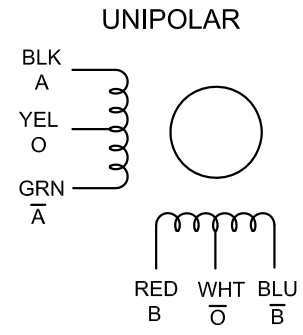

APVD		8.18.2018
CHKD		
1:1	DRN	
SCALE	SIGNATURE	DATE

STEPPER MOTOR

17HM13-0316D