

Features

- 1.6Gb/s Operation
- Non-blocking Architecture
- Duty-cycle Distortion: $\leq 150\text{pS}$
- $\leq 2\text{nS}$ Propagation Delay for Data Path
- $\leq 250\text{pS}$ Output to Output Skew in Broadcast Mode
- Power Supply: -2 V and 3.3 V
- ECL Differential Data Paths
- 3.3 V TTL Control Signals
- Low Power Dissipation
- Package: 256-pin LDCC

General Description

This VSC851 is a 32 x 32 crosspoint switch intended for high speed digital data communications applications. This product has 32 data inputs and 32 data outputs. Any input can be multiplexed to any, some, or all outputs. High speed digital data up to 1.6Gb/s can be switched with less than 150pS pulse width distortion. In broadcast mode, any two outputs will exhibit less than 250pS of skew relative to one another. Signals in data paths are fully differential to minimize duty cycle distortion. The VSC851 requires both -2V and 3.3V power supplies.

The address signals that control traffic patterns for data paths are double buffered. the *LSTROBE* signal load individual addresses for each output. The *GSTROBE* signal is used to update addresses for all 32 outputs simultaneously. This method allows users to configure any, some or all switches independently without disrupting data flow of the data paths. Broadcast and flow through functionality are controlled via *BROADCAST* and *FLOWTHRU* inputs.

This product is ideal for high speed digital applications including Gigabit Ethernet and ATM switch cores, data distribution for telecommunications, fiber channel networking, computer networking, multiprocessor switching, and test equipment. In a telecommunications SONET application, for example, the VSC851 can be used as an STS-12 protection switch.

The VSC851 is packaged in a 256 pin thermally enhanced LDCC package. This product is fabricated using Vitesse's E/D GaAs MESFET process which achieves high speed coupled with low power dissipation.

Functional Description

The VSC851 may be used to connect any one of 32 inputs to any one or combination of 32 output channels, according to a user defined bit pattern stored in each output channel's control latches (see Figure 1). For data path operation, signals flow transparently from inputs $I+/I-[0:31]$ to output channels $Z+/Z-[0:31]$ through thirty-two 32:1 multiplexers. The traffic pattern is controlled by data previously stored in thirty-two 5-bit control latches each corresponding to an output channel. Value of these 5-bit control latches is a binary numerical representation of the input channel selected. $D[4:0] = 00000$ corresponds to $I[0]$, $D[4:0] = 00001$ corresponds to $I[1]$, etc. Similarly, $A[4:0] = 00000$ selects path to output $Z[0]$, $A[4:0] = 00001$ to $Z[1]$, etc. To configure the switch, at rising edge of *LSTROBE*, the bank of holding registers for a particular channel is updated by input addresses $D[4:0]$ which describes a new path for that channel. After some or all holding registers are programmed, a high pulse is applied to *GSTROBE* to transfer the information from holding registers into all control latches. By this method, the entire crosspoint switch can be reconfigured simultaneously.

The VSC851 can be configured in Broadcast mode. In Broadcast Mode, at the rising edge of *LSTROBE*, all holding registers are updated by input addresses *D[4:0]*. If a high pulse is applied to *GSTROBE*, the entire crosspoint is configured and the selected data are broadcasted to all of the outputs.

In FlowThru mode, at the rising edge of *LSTROBE*, all holding registers are set to the numerical representation of the output which they control, (i.e., 00000 is loaded for output *Z[0]*, 00001 is loaded for output *Z[1]* etc.). If a high pulse is then applied to *GSTROBE*, these values are passed to the control latches. In this mode, data from *I[0]* is switched to *Z[0]* data from *I[1]* is switched to *Z[1]*, etc. The input address values at *D[4:0]* and the output address values at *A[4:0]* are ignored in FlowThru Mode. All data input and output signals (*I+/I-[0:31]*, *Z+/Z-[0:31]*) are differential ECL levels. All other signals are TTL levels. If both BROADCAST and FLOWTHRU inputs are asserted, the FlowThru Mode overrides the Broadcast Mode.

VSC851 Block Diagram

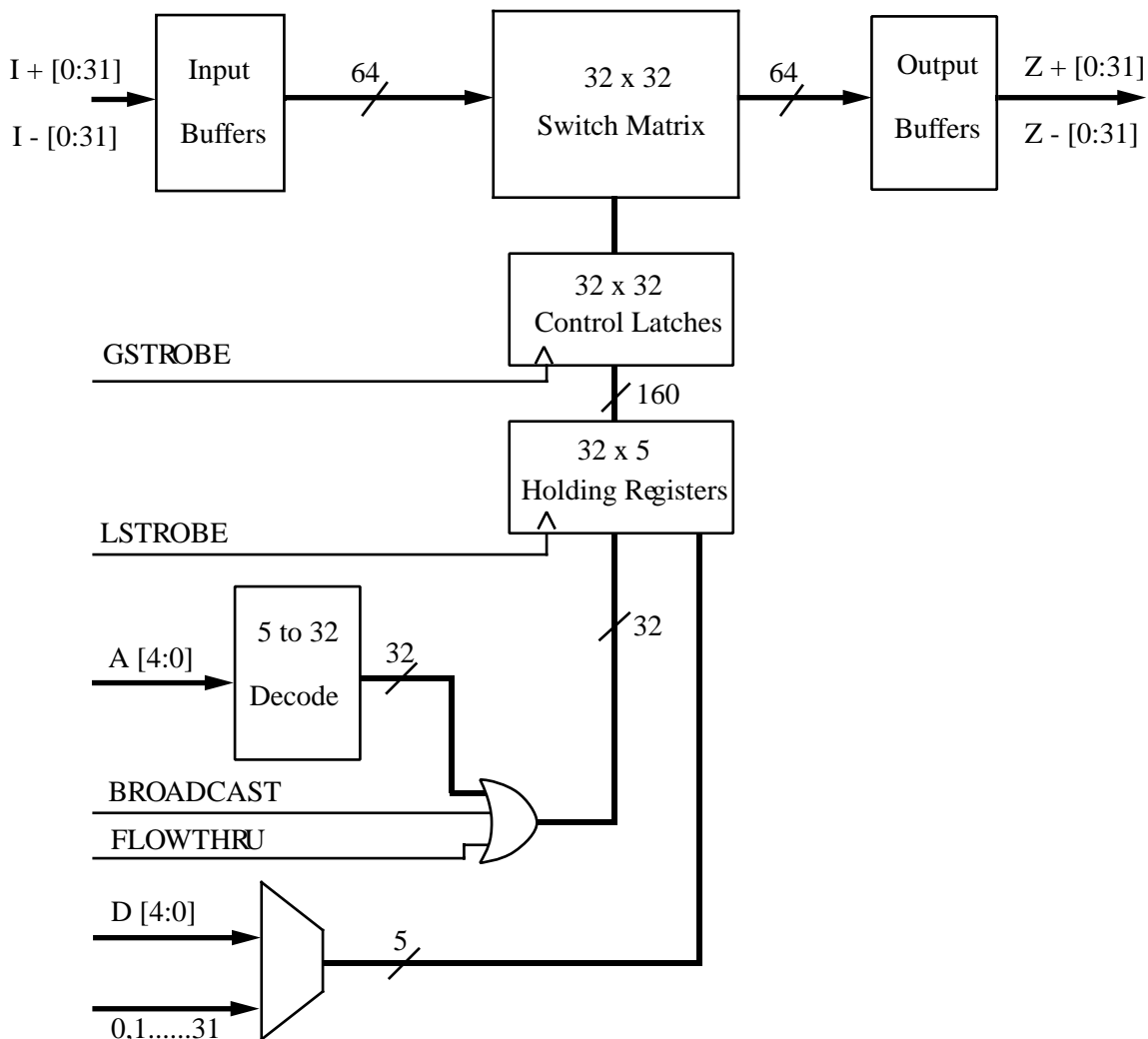

AC Characteristics (Over recommended operating conditions. ECL Output load 50Ω to V_{TT})

Table 1: Data Flow Mode.

Parameters	Description	Min	Typ	Max	Units	Conditions
T_{PW}	Minimum input pulse width	640	—	—	pS	Worst case 60/40 input duty cycle
T_{DLY}	Propagation delay	600	—	2000	pS	—
T_{duty}	Duty cycle distortion	—	—	150	pS	at 1.6 Gb/s Note(1)
T_{skew}	Output to output skew	—	—	250	pS	On a given part broadcast mode
T_{pskew}	Data path skew	—	—	500	pS	For any 2 paths from I+/I- to Z+/Z- on a given part

(1) Duty cycle distortion = duty cycle out - duty cycle in (pS). With 8B/10B encoded data.

AC Timing Waveforms

Figure 1: Normal Data Flow Timing

Minimum Input Pulse Width & Propagation Delay

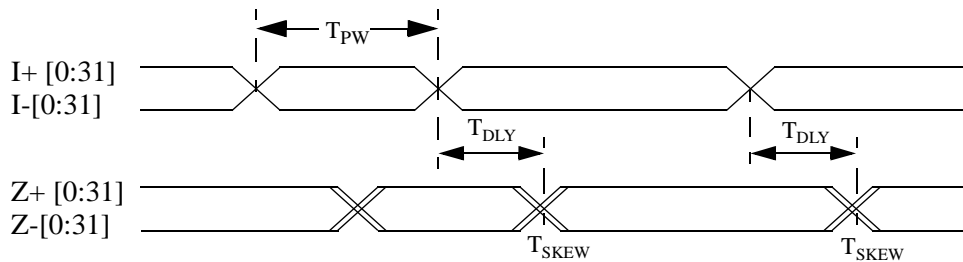

Table 2: Configuration, Broadcast, FlowThru Mode.

Parameters	Description	Min	Typ	Max	Units	Conditions
T_{LSW}	LSTROBE pulse width	5	—	—	nS	—
T_{GSW}	GSTROBE pulse width	5	—	—	nS	—
T_{GSZ}	GSTROBE to Z+/Z- Outputs Delay	1.5	—	5.0	nS	—
T_{LSZ}	LSTROBE to Z+/Z- Outputs Delay	2	—	6.0	nS	GSTROBE high
T_{ALSSU}	A[4:0] to LSTROBE setup time	3.5	—	—	nS	—
T_{ALSH}	A[4:0] to LSTROBE hold time	1	—	—	nS	—
T_{DLSSU}	D[4:0] to LSTROBE setup time	3.5	—	—	nS	—
T_{DLSH}	D[4:0] to LSTROBE hold time	1	—	—	nS	—
T_{GLSU}	GSTROBE to LSTROBE setup time	2.5	—	—	nS	—
T_{GLH}	GSTROBE to LSTROBE hold time	2	—	—	nS	—
T_{BLSSU}	BROADCAST to LSTROBE setup time	4	—	—	nS	—
T_{BLSH}	BROADCAST to LSTROBE hold time	1	—	—	nS	—
T_{FLSSU}	FLOWTHRU to LSTROBE setup time	4	—	—	nS	—
T_{FLSH}	FLOWTHRU to LSTROBE hold time	1	—	—	nS	—

Figure 2: Configuration Mode Timing

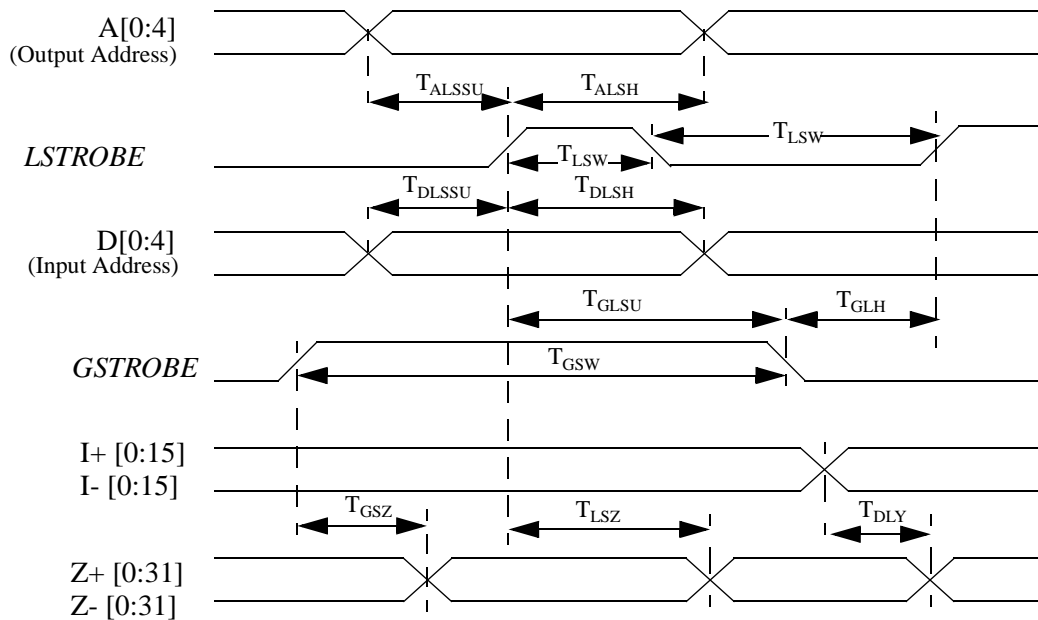
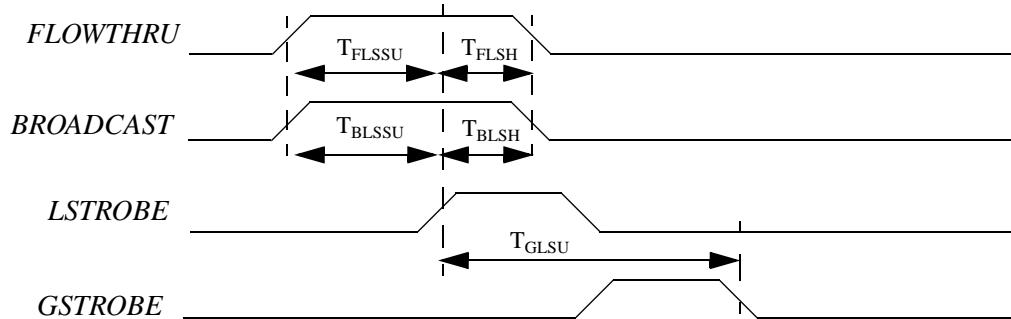

Figure 3: Broadcast and FlowThru Timing



DC Characteristics (Over recommended operating conditions. ECL Output load 50Ω to V_{TT})

Parameters	Description	Min	Typ	Max	Units	Conditions
V _{ODIF}	Differential ECL Output Voltage	600	—	1100	mV	50Ω to V _{TT}
V _{OCM}	Common Mode ECL Output Voltage	-1.5	—	-1.0	V	50Ω to V _{TT}
V _{IDIF}	Differential ECL Input Voltage	200	—	1200	mV	
V _{ICM}	Common Mode ECL Input Voltage	-1.5	—	-0.5	V	
I _{IHE}	Input HIGH ECL Current	—	—	+200	μA	V _{IN} = -0.7V
I _{ILE}	Input LOW ECL Current	-50	—	—	μA	V _{IN} = -2.0V
V _{IHT}	Input HIGH voltage (TTL)	2.0	—	4.3	V	
V _{ILT}	Input LOW voltage (TTL)	0	—	0.8	V	
I _{IHT}	Input HIGH current (TTL)	—	50	—	μA	2.0V < V _{IN} < 4.3V
I _{ILT}	Input LOW current (TTL)	-500	—	—	μA	-0.5V < V _{IN} < 0.8V
I _{VTTL}	VTTL Supply Current	—	—	20	mA	
I _{VTT}	VTT Supply Current	—	—	3600	mA	Outputs open
P _D	Power dissipation	—	—	7500	mW	

Absolute Maximum Ratings ⁽¹⁾

ECL Power Supply Voltage, V_{TT} potential to GND.....	-2.5V to +0.5V
TTL Power Supply Voltage, V_{TTL} potential to GND.....	-0.5V to +4.3V
ECL input Voltage Applied, V_{ECLIN}	V_{TT} -0.5V to +0.5V
TTL input Voltage Applied, V_{TTLIN}	-0.5V to V_{TTL} +1.0V
Output Current, I_{OUT} (DC, output HI).....	50 mA
Case Temperature Under Bias, T_C	-55° to +125°C
Storage Temperature (ambient), T_{STG}	-65°C to +150°C

Recommended Operating Conditions

ECL Supply Voltage, V_{TT}	-2.0V ± 5%
TTL Supply Voltage, V_{TTL}	3.3V ± 5%
Commercial Operating Temperature Range, T (2).....	0° to 70°C

NOTES: (1) CAUTION: Stresses listed under "Absolute Maximum Ratings" may be applied to devices one at a time without causing permanent damage. Functionality at or above the values listed is not implied. Exposure to these values for extended periods may affect device reliability.

(2) Lower limit of specification is ambient temperature and upper limit is case temperature.

Table 3: Package Pin Identification

<i>Signal</i>	<i>Pin</i>	<i>I/O</i>	<i>Level</i>	<i>Pin Description</i>
VTT	1	P	-2V	-2.0V power supply
VCC	2	P	GND	Ground
N/C	3			No connection
N/C	4			No connection
N/C	5			No connection
VTTL	6	P	+3.3V	+3.3V power supply
N/C	7			No connection
N/C	8			No connection
N/C	9			No connection
N/C	10			No connection
VTTL	11	P	+3.3V	+3.3V power supply
N/C	12			No connection
N/C	13			No connection
Z15	14	O	ECL	Serial data out
ZN15	15	O	ECL	Serial data out
VTT	16	P	-2V	-2.0V power supply
VCC	17	P	GND	Ground
VTTL	18	P	+3.3V	+3.3V power supply
N/C	19			No connection
Z14	20	O	ECL	Serial data out
ZN14	21	O	ECL	Serial data out
Z13	22	O	ECL	Serial data out
ZN13	23	O	ECL	Serial data out
VCC	24	P	GND	Ground
Z12	25	O	ECL	Serial data out
ZN12	26	O	ECL	Serial data out
Z11	27	O	ECL	Serial data out
ZN11	28	O	ECL	Serial data out
VCC	29	P	GND	Ground
Z10	30	O	ECL	Serial data out
ZN10	31	O	ECL	Serial data out
VTT	32	P	-2V	-2.0V power supply
VCC	33	P	GND	Ground
Z9	34	O	ECL	Serial data out
ZN9	35	O	ECL	Serial data out
VCC	36	P	GND	Ground
Z8	37	O	ECL	Serial data out

<i>Signal</i>	<i>Pin</i>	<i>I/O</i>	<i>Level</i>	<i>Pin Description</i>
ZN8	38	O	ECL	Serial data out
Z7	39	O	ECL	Serial data out
ZN7	40	O	ECL	Serial data out
VCC	41	P	GND	Ground
Z6	42	O	ECL	Serial data out
ZN6	43	O	ECL	Serial data out
Z5	44	O	ECL	Serial data out
ZN5	45	O	ECL	Serial data out
N/C	46			No connection
VCC	47	P	GND	Ground
VTT	48	P	-2V	-2.0V power supply
VCC	49	P	GND	Ground
Z4	50	O	ECL	Serial data out
ZN4	51	O	ECL	Serial data out
Z3	52	O	ECL	Serial data out
ZN3	53	O	ECL	Serial data out
VCC	54	P	GND	Ground
Z2	55	O	ECL	Serial data out
ZN2	56	O	ECL	Serial data out
Z1	57	O	ECL	Serial data out
ZN1	58	O	ECL	Serial data out
VCC	59	P	GND	Ground
Z0	60	O	ECL	Serial data out
ZN0	61	O	ECL	Serial data out
I0	62	I	ECL	Serial data in
VTT	63	P	-2V	-2.0V power supply
VCC	64	P	GND	Ground
IN0	65	I	ECL	Serial data in
I1	66	I	ECL	Serial data in
IN1	67	I	ECL	Serial data in
VCC	68	P	GND	Ground
VTT	69	P	-2V	-2.0V power supply
VCC	70	P	GND	Ground
N/C	71			No connection
I2	72	I	ECL	Serial data in
IN2	73	I	ECL	Serial data in
I3	74	I	ECL	Serial data in
IN3	75	I	ECL	Serial data in
I4	76	I	ECL	Serial data in

<i>Signal</i>	<i>Pin</i>	<i>I/O</i>	<i>Level</i>	<i>Pin Description</i>
IN4	77	I	ECL	Serial data in
I5	78	I	ECL	Serial data in
IN5	79	I	ECL	Serial data in
I6	80	I	ECL	Serial data in
IN6	81	I	ECL	Serial data in
N/C	82			No connection
I7	83	I	ECL	Serial data in
IN7	84	I	ECL	Serial data in
I8	85	I	ECL	Serial data in
IN8	86	I	ECL	Serial data in
VTT	87	P	-2V	-2.0V power supply
VCC	88	P	GND	Ground
I9	89	I	ECL	Serial data in
IN9	90	I	ECL	Serial data in
I10	91	I	ECL	Serial data in
IN10	92	I	ECL	Serial data in
I11	93	I	ECL	Serial data in
IN11	94	I	ECL	Serial data in
I12	95	I	ECL	Serial data in
IN12	96	I	ECL	Serial data in
I13	97	I	ECL	Serial data in
IN13	98	I	ECL	Serial data in
I14	99	I	ECL	Serial data in
IN14	100	I	ECL	Serial data in
I15	101	I	ECL	Serial data in
IN15	102	I	ECL	Serial data in
I16	103	I	ECL	Serial data in
IN16	104	I	ECL	Serial data in
VTT	105	P	-2.0V	-2.0V power supply
VCC	106	P	GND	Ground
I17	107	I	ECL	Serial data in
IN17	108	I	ECL	Serial data in
I18	109	I	ECL	Serial data in
IN18	110	I	ECL	Serial data in
N/C	111			No connection
I19	112	I	ECL	Serial data in
IN19	113	I	ECL	Serial data in
I20	114	I	ECL	Serial data in
IN20	115	I	ECL	Serial data in

<i>Signal</i>	<i>Pin</i>	<i>I/O</i>	<i>Level</i>	<i>Pin Description</i>
I21	116	I	ECL	Serial data in
IN21	117	I	ECL	Serial data in
I22	118	I	ECL	Serial data in
IN22	119	I	ECL	Serial data in
I23	120	I	ECL	Serial data in
IN23	121	I	ECL	Serial data in
N/C	122			No connection
VTT	123	P	-2V	-2.0V power supply
VCC	124	P	GND	Ground
VCC	125	P	GND	Ground
I24	126	I	ECL	Serial data in
IN24	127	I	ECL	Serial data in
I25	128	I	ECL	Serial data in
VTT	129	P	-2V	-2.0V power supply
VCC	130	P	GND	Ground
IN25	131	I	ECL	Serial data in
I26	132	I	ECL	Serial data in
IN26	133	I	ECL	Serial data in
VCC	134	P	GND	Ground
I27	135	I	ECL	Serial data in
IN27	136	I	ECL	Serial data in
I28	137	I	ECL	Serial data in
IN28	138	I	ECL	Serial data in
VCC	139	P	GND	Ground
I29	140	I	ECL	Serial data in
IN29	141	I	ECL	Serial data in
I30	142	I	ECL	Serial data in
IN30	143	I	ECL	Serial data in
VTT	144	P	-2V	-2.0V power supply
VCC	145	P	GND	Ground
VCC	146	P	GND	Ground
N/C	147			No connection
I31	148	I	ECL	Serial data in
IN31	149	I	ECL	Serial data in
Z31	150	O	ECL	Serial data out
ZN31	151	O	ECL	Serial data out
VCC	152	P	GND	Ground
Z30	153	O	ECL	Serial data out
ZN30	154	O	ECL	Serial data out

Data Sheet VSC851

1.6 Gb/s 32 X 32
Crosspoint Switch

<i>Signal</i>	<i>Pin</i>	<i>I/O</i>	<i>Level</i>	<i>Pin Description</i>
Z29	155	O	ECL	Serial data out
ZN29	156	O	ECL	Serial data out
VCC	157	P	GND	Ground
Z28	158	O	ECL	Serial data out
ZN28	159	O	ECL	Serial data out
VTT	160	P	-2V	-2.0V power supply
VCC	161	P	GND	Ground
Z27	162	O	ECL	Serial data out
ZN27	163	O	ECL	Serial data out
VCC	164	P	GND	Ground
Z26	165	O	ECL	Serial data out
ZN26	166	O	ECL	Serial data out
Z25	167	O	ECL	Serial data out
ZN25	168	O	ECL	Serial data out
VCC	169	P	GND	Ground
Z24	170	O	ECL	Serial data out
ZN24	171	O	ECL	Serial data out
Z23	172	O	ECL	Serial data out
ZN23	173	O	ECL	Serial data out
N/C	174			No connection
VTTL	175	P	+3.3V	+3.3V power supply
VTT	176	P	-2V	-2.0V power supply
VCC	177	P	GND	Ground
Z22	178	O	ECL	Serial data out
ZN22	179	O	ECL	Serial data out
Z21	180	O	ECL	Serial data out
ZN21	181	O	ECL	Serial data out
VTTL	182	P	+3.3V	+3.3V power supply
Z20	183	O	ECL	Serial data out
ZN20	184	O	ECL	Serial data out
Z19	185	O	ECL	Serial data out
ZN19	186	O	ECL	Serial data out
VTTL	187	P	+3.3V	+3.3V power supply
Z18	188	O	ECL	Serial data out
ZN18	189	O	ECL	Serial data out
Z17	190	O	ECL	Serial data out
VTT	191	P	-2V	-2.0V power supply
VCC	192	P	GND	Ground
ZN17	193	O	ECL	Serial data out

<i>Signal</i>	<i>Pin</i>	<i>I/O</i>	<i>Level</i>	<i>Pin Description</i>
Z16	194	O	ECL	Serial data out
ZN16	195	O	ECL	Serial data out
VCC	196	P	GND	Ground
VTT	197	P	-2V	-2.0V power supply
VCC	198	P	GND	Ground
N/C	199			No connection
N/C	200			No connection
N/C	201			No connection
N/C	202			No connection
N/C	203			No connection
VSCTE	204!	I	-2.0	Test enable (tie to -2V)
N/C	205			No connection
N/C	206			No connection
N/C	207			No connection
N/C	208			No connection
N/C	209			No connection
N/C	210			No connection
N/C	211			No connection
N/C	212			No connection
N/C	213			No connection
N/C	214			No connection
VTT	215	P	-2V	-2.0V power supply
VCC	216	P	GND	Ground
N/C	217			No connection
N/C	218			No connection
N/C	219			No connection
A4	220	I	TTL	Output address
A3	221	I	TTL	Output address
A2	222	I	TTL	Output address
A1	223	I	TTL	Output address
A0	224	I	TTL	Output address
BROADCAST	225	I	TTL	Control signal to enable flow thru mode
FLOWTHRU	226	I	TTL	Control signal to enable flow thru mode
LSTROBE	227	I	TTL	Load addresses into holding registers
D4	228	I	TTL	Input address
D3	229	I	TTL	Input address
D2	230	I	TTL	Input address
D1	231	I	TTL	Input address
D0	232	I	TTL	Input address

Data Sheet
VSC851

1.6 Gb/s 32 X 32
Crosspoint Switch

<i>Signal</i>	<i>Pin</i>	<i>I/O</i>	<i>Level</i>	<i>Pin Description</i>
VTT	233	P	-2V	-2.0V power supply
VCC	234	P	GND	Ground
N/C	235			No connection
N/C	236			No connection
N/C	237			No connection
N/C	238			No connection
N/C	239			No connection
N/C	240			No connection
N/C	241			No connection
N/C	242			No connection
N/C	243			No connection
N/C	244			No connection
N/C	245			No connection
N/C	246			No connection
GSTROBE	247	I	TTL	Latch enable to transfer holding register data to control latches
N/C	248			No connection
N/C	249			No connection
N/C	250			No connection
VTT	251	P	-2V	-2.0V power supply
VCC	252	P	GND	Ground
VCC	253	P	GND	Ground
VSCIPNC	254*	I	TTL	Test input (tie to -2V)
VSCOPNC	255#	O	ECL	Test output (leave open)
N/C	256			No connection

Package Information

256 LDCC Cavity Down Package

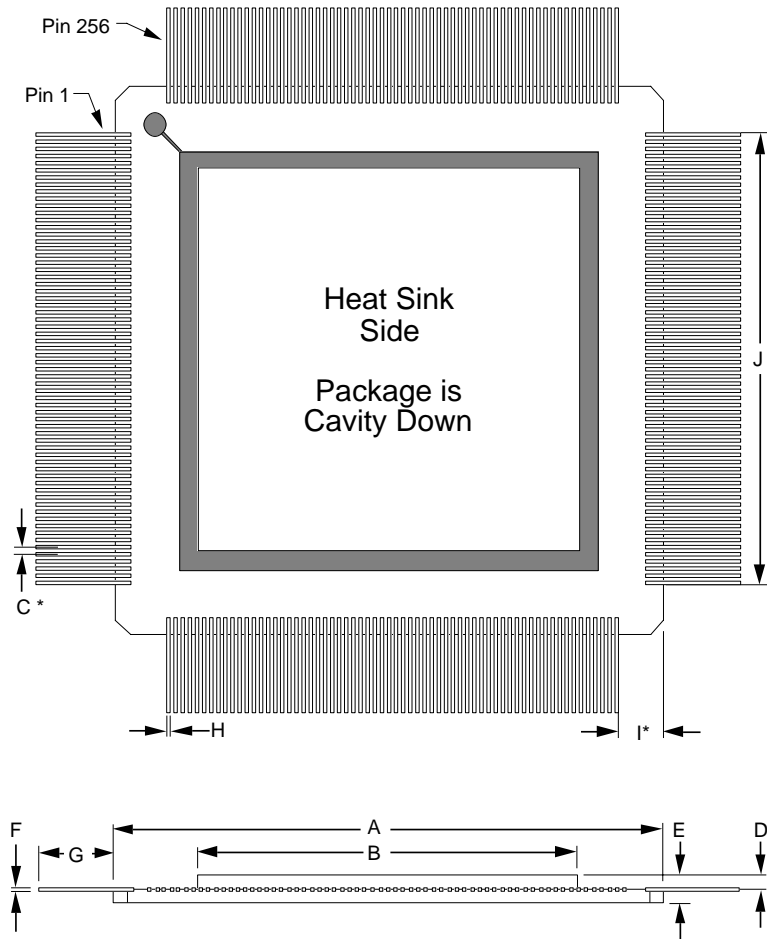

Item	mm (Min/Max)	In (Min/Max)	Item	mm (Min/Max)	In (Min/Max)
A	36.57/37.59 SQ	1.440/1.480 SQ	F	0.09/0.216	0.004/0.008
B	TYP 28 SQ	TYP 1.1 SQ	G	5.08/7.62	0.200/0.300
C*	0.51 TYP	0.020 TYP	H	0.15/0.25	0.006/0.010
D	0.38/0.63	0.015/0.025	I*	REF 2.54 TYP	REF 0.100 TYP
E	2.16/2.92	0.085/0.115	J*	32.00 TYP	1.26 TYP

*At package body.

Notes: 1) Drawing not to scale.

2) Packages: Ceramic (alumina); Heat sinks: Copper-tungsten; Leads: Alloy 42 with gold plating

Ordering Information

VSC851-FX

Device Type:

VSC851: 32x32 Crosspoint Switch

Package Type

F: 256 LDCC

Notice

Vitesse Semiconductor Corporation reserves the right to make changes in its products, specifications or other information at any time without prior notice. Therefore the reader is cautioned to confirm that this datasheet is current prior to placing any orders. The company assumes no responsibility for any circuitry described other than circuitry entirely embodied in a Vitesse product.

Warning

Vitesse Semiconductor Corporation's products are not intended for use in life support appliances, devices or systems. Use of a Vitesse product in such applications without the written consent is prohibited.

1.6 Gb/s 32x32
Crosspoint Switch

Data Sheet
VSC851

