

SOT-223



Pin Definition:

- 1. Input
- 2. Ground (tab)
- 3. Output

General Description

The TS4264GCW50 is a monolithic integrated low-drop fixed voltage regulator which can supply loads up to 150mA. It is functional compatible to the TS4264GCW50 but has a reduced quiescent current of typ. 40µA. The TS4264GCW50 is especially designed for all applications which are require very low quiescent currents. This ULDO is designed to supply microprocessor systems under the severe condition of automotive applications and is therefore equipped with additional protection against overload, short-circuit and over temperature. Of course the TS4264GCW50 can be used in all other applications, wherever a stabilized voltage is required.

An input voltage in the range of 5.5V ~ 45V is regulated to $V_{OUT} = 5V$ with an accuracy of $\pm 3\%$. An accuracy of $\pm 2\%$ is kept for a load current range up to 50mA. The device operates in the temperature range of $T_J = -40 \sim 150^\circ C$.

Features

- Fixed Output Voltage 5V
- Output Voltage Tolerance $\pm 3\%$
- 150mA Current Capability
- Ultra Low Quiescent Current 40uA (Typ.)
- Over Temperature Protection
- Short-Circuit Proof
- Reverse Polarity Proof
- Wide Temperature Polarity Range
- Suitable for use in Automotive Electronics

Ordering Information

Part No.	Package	Packing
TS4264GCW50 RP	SOT-223	2.5Kpcs / 13" Reel

Pin Definition and Function

Pin	Symbol	Function
1	Input	Block to ground directly on IC with ceramic capacitor
2	Ground	Ground
3	Output	Block to ground with 10uF capacitor, ESR < 4Ω

Block Diagram

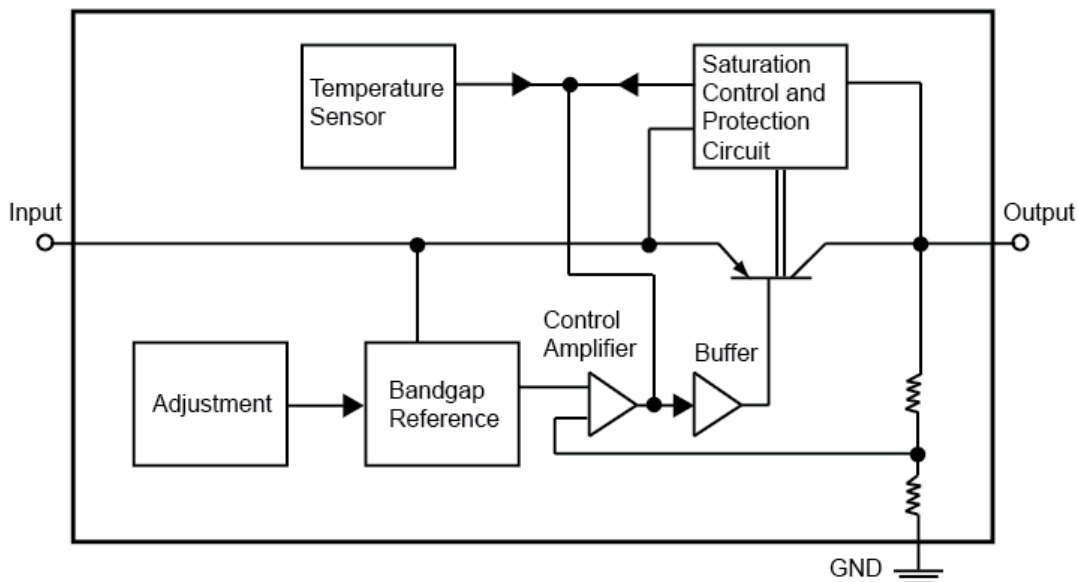

Absolute Maximum Rating

Parameter	Symbol	Limit Values		Unit	Notes
		Min.	Max.		
Input Voltage	V_{IN}	-42	45	V	
Input Voltage (Operating Range)	$V_{IN(OPR)}$	5.5	45	V	
Input Current	I_{IN}	--	--	--	Internally Limited
Output Voltage	V_{OUT}	-0.3	32	V	
Output Current	I_{OUT}	--	--	--	Internally Limited
Ground Current	I_{GND}	50	--	mA	
Junction Temperature	T_J	--	150	°C	
Junction Temperature (Operating Range)	$T_{J(OPR)}$	-40	150	°C	
Storage Temperature	T_{STG}	-50	150	°C	

Thermal Performance

Parameter	Symbol	Limit Values		Unit	Notes
		Min.	Max.		
Thermal Resistance Junction-Ambient	$R\theta_{JA}$	--	80	°C/W	
Thermal Resistance Junction-Pin	$R\theta_{JP}$	--	17	°C/W	

Note: Measured to pin 2 (tab)

Electrical Characteristics $V_{IN}=13.5V$, $-40 \leq T_J \leq +150$, unless otherwise specified.

Parameter	Symbol	Limit Values			Unit	Notes
		Min.	Typ.	Max.		
Output Voltage	V_{OUT}	4.85	5.0	5.15	V	$6V \leq V_{IN} \leq 21V$, $5mA \leq I_o \leq 100mA$
Output Voltage	V_{OUT}	4.90	5.0	5.10	V	$6V \leq V_{IN} \leq 16V$, $5mA \leq I_o \leq 50mA$
Output Current Limit	I_{OUT}	150	200	500	mA	
Current Consumption	I_Q	--	40	60	uA	$I_o = 100\mu A$, $T_J \leq 85^\circ C$
		--	40	70		$I_o = 100\mu A$
		--	1.7	4	mA	$I_o = 50mA$
Dropout Voltage (Note)	V_{DROP}	--	0.22	0.5	V	$I_o = 100mA$
Load Regulation	REG_{LOAD}	--	50	90	mV	$5mA \leq I_o \leq 100mA$, $V_{IN} = 13.5V$
Line Regulation	REG_{LINE}	--	5	30	mV	$6V \leq V_{IN} \leq 28V$, $I_o = 1mA$
Ripple Rejection	PSRR	--	68	--	dB	$f = 100Hz$, $V_R = 0.5V_{PP}$
Output Capacitor	C_{OUT}	10	--	--	uF	$ESR \leq 4\Omega @ 10kHz$

Note: Dropout voltage = $V_{IN} - V_{OUT}$

(Measured where V_{OUT} has dropped 100mV from the nominal value obtained at $V_{IN} = 13.5V$)

Application Information

In the TS4264GCW50 the output voltage is divided and compared to an internal reference of 2.5V typical. The regulation loop controls the output to achieve an output voltage of 5V with an accuracy of $\pm 3\%$ at an input voltage range of 5.5V~45V.

Circuit Description

The control amplifier compares a reference voltage, which is kept highly precise by resistance adjustment, to a voltage that is proportional to the output voltage and drives the base of the series transistor via a buffer. Saturation control, working as a function of load current, prevents any over-saturation of the power element. The IC is additionally protected against overload, over temperature and reverse polarity

Typical Application Circuit

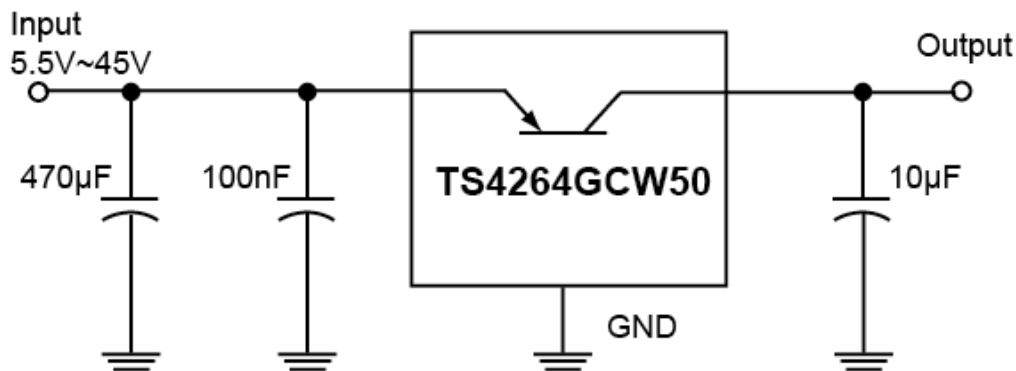

Dimensioning Information on External Components

The input capacitor C_{IN} is necessary for compensating line influences. Using a resistor of approx. 1Ω in series with C_{IN} , the oscillating of input inductivity and input capacitance can be clamped. The output capacitor C_{OUT} is necessary for the stability of the regulating circuit. Stability is guaranteed at values $C_{OUT} \geq 10\mu F$ and an $ESR \leq 4\Omega$ within the operating temperature range.

The application circuit shows additional electrolytic input capacitor of 470uF is added in order to buffer supply line influences. This capacitor is recommended, if the device is sourced via long supply lines of several meters.

The TS4264GCW50 can supply up to 150mA. However for protection for high input voltage above 25V, the output current is reduced (SOA protection).

SOT-223 Mechanical Drawing

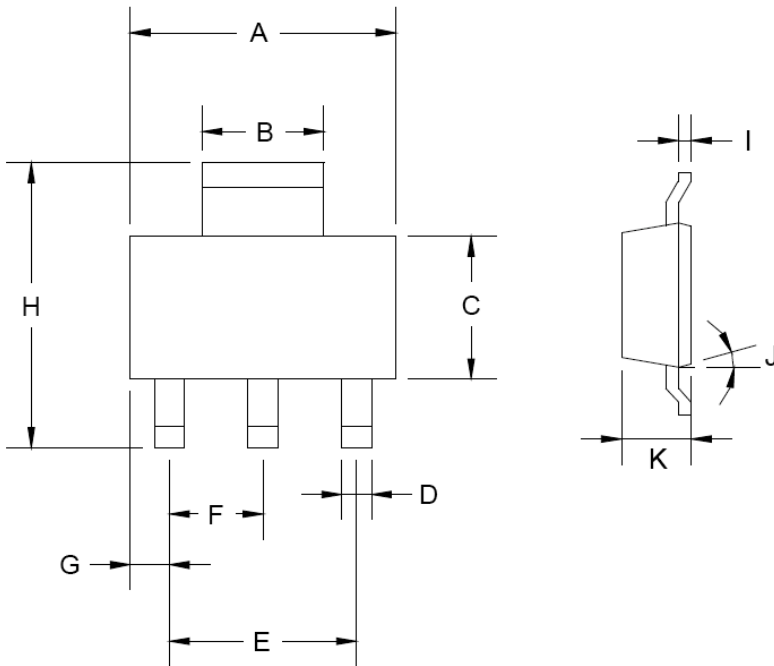

DIM	SOT-223 DIMENSION			
	MILLIMETERS		INCHES	
	MIN	MAX	MIN	MAX
A	6.350	6.850	0.250	0.270
B	2.900	3.100	0.114	0.122
C	3.450	3.750	0.136	0.148
D	0.595	0.635	0.023	0.025
E	4.550	4.650	0.179	0.183
F	2.250	2.350	0.088	0.093
G	0.835	1.035	0.032	0.041
H	6.700	7.300	0.263	0.287
I	0.250	0.355	0.010	0.014
J	10°	16°	10°	16°
K	1.550	1.800	0.061	0.071

Marking Diagram

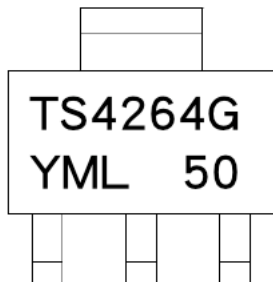

- Y** = Year Code
- M** = Month Code
(A=Jan, B=Feb, C=Mar, D=Apl, E=May, F=Jun, G=Jul, H=Aug, I=Sep, J=Oct, K=Nov, L=Dec)
- L** = Lot Code
- 50** = 5V Fixed Output Voltage

Notice

Specifications of the products displayed herein are subject to change without notice. TSC or anyone on its behalf, assumes no responsibility or liability for any errors or inaccuracies.

Information contained herein is intended to provide a product description only. No license, express or implied, to any intellectual property rights is granted by this document. Except as provided in TSC's terms and conditions of sale for such products, TSC assumes no liability whatsoever, and disclaims any express or implied warranty, relating to sale and/or use of TSC products including liability or warranties relating to fitness for a particular purpose, merchantability, or infringement of any patent, copyright, or other intellectual property right.

The products shown herein are not designed for use in medical, life-saving, or life-sustaining applications. Customers using or selling these products for use in such applications do so at their own risk and agree to fully indemnify TSC for any damages resulting from such improper use or sale.