

Silicon NPN Power Transistor

BDY81

DESCRIPTION

- Continuous Collector Current- $I_C= 4A$
- Collector Power Dissipation-
 $P_C= 36W @T_C= 25^\circ C$
- Complement to Type BDY83

APPLICATIONS

- Designed for general purpose switching and amplifier applications.

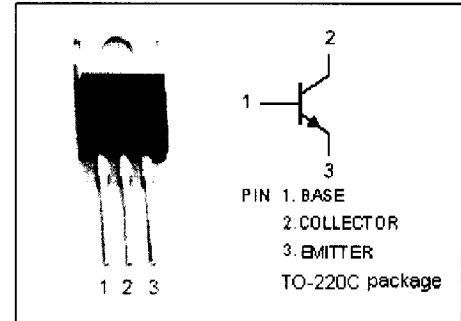

ABSOLUTE MAXIMUM RATINGS($T_a=25^\circ C$)

SYMBOL	PARAMETER	VALUE	UNIT
V_{CBO}	Collector-Base Voltage	60	V
V_{CEX}	Collector-Emitter Voltage $V_{BE} = -1.5V$	60	V
V_{CEO}	Collector-Emitter Voltage	50	V
V_{EBO}	Emitter-Base Voltage	10	V
I_C	Collector Current-Continuous	4	A
I_B	Base Current-Continuous	2	A
P_C	Collector Power Dissipation@ $T_C=25^\circ C$	36	W
T_J	Junction Temperature	150	$^\circ C$
T_{stg}	Storage Temperature	-55~175	$^\circ C$

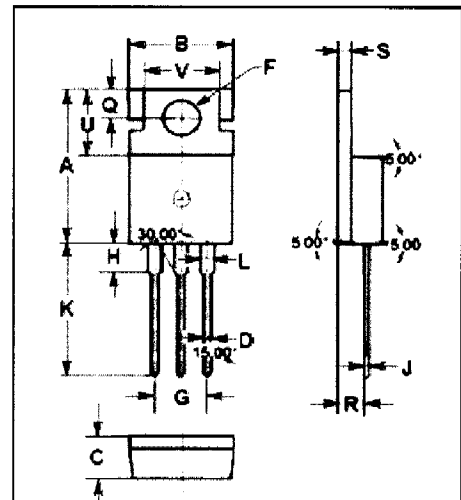

DIM	mm	
	MIN	MAX
A	15.70	15.90
B	9.90	10.10
C	4.20	4.40
D	0.70	0.90
F	3.40	3.60
G	4.98	5.18
H	2.70	2.90
J	0.44	0.46
K	13.20	13.40
L	1.10	1.30
Q	2.70	2.90
R	2.50	2.70
S	1.29	1.31
U	6.45	6.65
V	8.66	8.86

THERMAL CHARACTERISTICS

SYMBOL	PARAMETER	MAX	UNIT
$R_{th\ j-c}$	Thermal Resistance, Junction to Case	3.5	$^\circ C/W$

NJ Semi-Conductors reserves the right to change test conditions, parameter limits and package dimensions without notice. Information furnished by NJ Semi-Conductors is believed to be both accurate and reliable at the time of going to press. However, NJ Semi-Conductors assumes no responsibility for any errors or omissions discovered in its use. NJ Semi-Conductors encourages customers to verify that datasheets are current before placing orders.

Silicon NPN Power Transistor

BDY81

ELECTRICAL CHARACTERISTICS

$T_C=25^\circ\text{C}$ unless otherwise specified

SYMBOL	PARAMETER	CONDITIONS	MIN	TYP.	MAX	UNIT
$V_{CEO(SUS)}$	Collector-Emitter Sustaining Voltage	$I_C=100\text{mA}; I_B=0$	50			V
$V_{(BR)CBO}$	Collector-Base Breakdown Voltage	$I_C=10\text{mA}; I_E=0$	60			V
$V_{(BR)EBO}$	Emitter-Base Breakdown Voltage	$I_E=10\text{mA}; I_C=0$	10			V
$V_{CE(sat)}$	Collector-Emitter Saturation Voltage	$I_C=3\text{A}; I_B=0.3\text{A}$			1.5	V
$V_{BE(on)}$	Base-Emitter On Voltage	$I_C=0.5\text{A}; V_{CE}=5\text{V}$			0.9	V
I_{CEO}	Collector Cutoff Current	$V_{CE}=20\text{V}; I_B=0$			10	mA
I_{CBO}	Collector Cutoff Current	$V_{CB}=20\text{V}; I_E=0$			0.2	mA
I_{EBO}	Emitter Cutoff Current	$V_{EB}=5\text{V}; I_C=0$			0.1	mA
h_{FE-1}	DC Current Gain	$I_C=0.5\text{A}; V_{CE}=5\text{V}$	40		240	
h_{FE-2}	DC Current Gain	$I_C=2.5\text{A}; V_{CE}=5\text{V}$	10			
f_T	Current Gain-Bandwidth Product	$I_C=0.5\text{A}; V_{CE}=10\text{V}$		1		MHz

◆ h_{FE-1} Classifications

A	B	C
40-80	70-140	120-240