

QAE100W SERIES

QUARTER-BRICK DC-DC CONVERTER

4:1 ULTRA WIDE INPUT RANGE
UP TO 90Watts

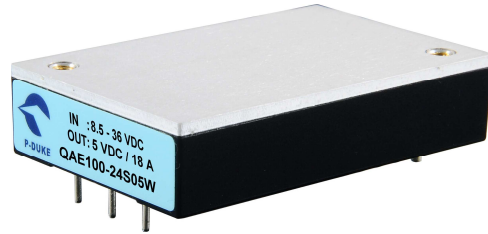

FEATURES

- NO MINIMUM LOAD REQUIRED
- LOW STANDBY POWER CONSUMPTION
- 2250VDC INPUT TO OUTPUT BASIC INSULATION
- SAFETY MEETS UL60950-1, EN60950-1, IEC60950-1, & EN50155
- CE MARKED
- COMPLIANT TO RoHS II & REACH

APPLICATIONS

- RAILWAY SYSTEM
- WIRELESS NETWORK
- TELECOM/DATACOM
- INDUSTRY CONTROL SYSTEM
- DISTRIBUTED POWER ARCHITECTURES
- SEMICONDUCTOR EQUIPMENT

2250VDC ISOLATION	REMOTE CONTROL	UVP	OCP	SCP	OVP	OTP	LOW STANDBY POWER
-------------------	----------------	-----	-----	-----	-----	-----	-------------------

TECHNICAL SPECIFICATION

All specifications are typical at nominal input, full load and 25°C otherwise noted

Model Number	Input Range	Output Voltage	Output Current @Full Load	Input Current @ No Load	Efficiency	Maximum Capacitor Load
	VDC	VDC	A	mA		
QAE100-24S3P3W	8.5 ~ 36	3.3	25	25	88	75000
QAE100-24S05W	8.5 ~ 36	5	18	25	89	36000
QAE100-24S12W	8.5 ~ 36	12	7.5	25	89	6250
QAE100-24S15W	8.5 ~ 36	15	6	25	89	4000
QAE100-24S24W	8.5 ~ 36	24	3.7	25	89	1540
QAE100-24S30W	8.5 ~ 36	30	3	25	89	1000
QAE100-24S48W	8.5 ~ 36	48	1.8	25	88	380
QAE100-48S3P3W	16.5 ~ 75	3.3	25	15	88	75000
QAE100-48S05W	16.5 ~ 75	5	18	15	89	36000
QAE100-48S12W	16.5 ~ 75	12	7.5	15	89	6250
QAE100-48S15W	16.5 ~ 75	15	6	15	90	4000
QAE100-48S24W	16.5 ~ 75	24	3.7	15	90	1540
QAE100-48S30W	16.5 ~ 75	30	3	15	90	1000
QAE100-48S48W	16.5 ~ 75	48	1.8	15	90	380
QAE100-110S3P3W	40 ~ 160	3.3	23	8	88	70000
QAE100-110S05W	40 ~ 160	5	17	8	89	34000
QAE100-110S12W	40 ~ 160	12	7	8	89	5830
QAE100-110S15W	40 ~ 160	15	5.5	8	89	3670
QAE100-110S24W	40 ~ 160	24	3.5	8	89	1460
QAE100-110S30W	40 ~ 160	30	2.8	8	89	930
QAE100-110S48W	40 ~ 160	48	1.8	8	89	380

PART NUMBER STRUCTURE

QAE100	-	48	S	05	W	-	P	HS
Series Name		Input Voltage (VDC)	Output Quantity	Output Voltage (VDC)	Input Range		Ctrl and Pin Options	Heat-sink and Mounting Hole Tread Options
		24:8.5~36 48:16.5~75 110:40~160	S:Single	3P3:3.3 05:5 12:12 15:15 24:24 30:30 48:48	4:1		□:Negative logic P:Positive logic	□:NC HS:H=0.24" Horizontal, 7G-0029A-F HS1:H=0.5" Horizontal, 7G-0030A-F HS2:H=0.24" Vertical, 7G-0031A-F HS3:H=0.5" Vertical, 7G-0032A-F TH:Through hole (No thread) ⁽¹⁾

(1) The module can't equip Heat-sink with TH option.

INPUT SPECIFICATIONS

Parameter	Conditions		Min.	Typ.	Max.	Unit
Operating input voltage range	24Vin(nom)		8.5	24	36	VDC
	48Vin(nom)		16.5	48	75	
	110Vin(nom)		40	110	160	
Start-up voltage	24Vin(nom)				9	VDC
	48Vin(nom)				18	
	110Vin(nom)				43	
Shutdown voltage	24Vin(nom)		7.3		8.1	VDC
	48Vin(nom)		15.5		16.3	
	110Vin(nom)		33.0		36.0	
Start up time	Constant resistive load	Power up		75	100	ms
		Remote ON/OFF		75	100	
Input surge voltage	1 second, max.	24Vin(nom)			50	VDC
		48Vin(nom)			100	
		110Vin(nom)			185	
Input filter ⁽¹⁾			Pi type			
Remote ON/OFF	Referred to -Vin pin	Negative logic	DC-DC ON	Short or 0 ~ 1.2VDC		mA
		(Standard)	DC-DC OFF	Open or 3 ~ 12 VDC		
		Positive logic	DC-DC ON	Open or 3 ~ 12 VDC		
		(Option)	DC-DC OFF	Short or 0 ~ 1.2VDC		
		Input current of Ctrl pin		-0.5		
		Remote off input current		3		mA

OUTPUT SPECIFICATIONS

Parameter	Conditions		Min.	Typ.	Max.	Unit
Voltage accuracy			-1.0		+1.0	%
Line regulation	Low Line to High Line at Full Load		-0.1		+0.1	%
Load regulation	No Load to Full Load	3.3 & 5Vout	-0.2		+0.2	%
		Others	-0.1		+0.1	
Voltage adjustability	Maximum output deviation is inclusive of remote sense		-20		+10	%
Remote sense	% of Vout(nom). If remote sense is not being used, sense pins should connect to the output pins with the same polarity.				10	%
Ripple and noise	Measured by 20MHz bandwidth					mVp-p
	With a 22µF/25V X7R MLCC	3.3Vout, 5Vout		75		
	With a 22µF/25V X7R MLCC	12Vout, 15Vout		100		
	With a 4.7µF/50V X7R MLCC	24Vout, 30Vout		200		
	With a 2.2µF/100V X7R MLCC	48Vout		300		
Temperature coefficient			-0.02		+0.02	%/°C
Transient response recovery time	25% load step change			250		µs
Over voltage protection	% of Vout(nom); Hiccup mode		115		130	%
Over load protection	% of Iout rated; Hiccup mode		110		140	%
Short circuit protection			Continuous, automatic recovery			

GENERAL SPECIFICATIONS

Parameter	Conditions		Min.	Typ.	Max.	Unit
Isolation voltage	1 minute (Basic insulation)	Input to Output	2250			VDC
		Input (Output) to Base-Plate	2250			
Isolation resistance	500VDC		1			GΩ
Isolation capacitance					1500	pF
Switching frequency			270	300	330	kHz
Safety meets			UL60950-1 EN60950-1 IEC60950-1 EN50155			
Case material			Aluminum base-plate with plastic case			
Potting material			Silicone (UL94 V-0)			
Weight			64g (2.26oz)			
MTBF	MIL-HDBK-217F, Full load		5.070 x 10 ⁵ hrs			

ENVIRONMENTAL SPECIFICATIONS

Parameter	Conditions	Min.	Typ.	Max.	Unit
Operating base-plate temperature		-40		+100	°C
Over temperature protection			+110		°C
Storage temperature range		-55		+125	°C
Thermal impedance (2)	Vertical direction by natural convection (20LFM)		9		°C/W
	Mount on 2U iron base-plate		2.8		
	With 0.24" Height Heat-sink		7.1		
	With 0.5" Height Heat-sink		5.5		
Thermal shock					MIL-STD-810F
Shock					EN61373, MIL-STD-810F
Vibration					EN61373, MIL-STD-810F
Relative humidity					5% to 95% RH

EMC SPECIFICATIONS

Parameter	Conditions	Level
EMI (3)	EN55011, EN55022	Class A Class B
ESD	EN61000-4-2 Air ± 8kV Contact ± 6kV	Perf. Criteria A
Radiated immunity	EN61000-4-3 20 V/m	Perf. Criteria A
Fast transient (4)	EN61000-4-4 ± 2kV	Perf. Criteria A
Surge (4)	EN61000-4-5 EN55024:±2kV EN50155:±2kV	Perf. Criteria A
Conducted immunity	EN61000-4-6 10 Vr.m.s	Perf. Criteria A

Note:

- Input source impedance: The power modules will operate as specifications without external components, assuming that the source voltage has a very low impedance and reasonable input voltage regulation. Highly inductive source impedances can affect the stability of the power module. Since real-world voltage source has finite impedance, performance can be improved by adding external filter capacitor. The QAE100-24SXXW and QAE100-48SXXW recommended Nippon Chemi-con KY series, 100µF/100V. The QAE100-110SXXW recommended Ruby-con BXF series, 39µF/200V.
- The heat-sink is optional and P/N: 7G-0029A-F , 7G-0030A-F , 7G-0031A-F , 7G-0032A-F. Please refer to heat-sink selection guide.
- The standard modules meet EMI Class A or Class B with external components. For further information, please contact with P-DUKE.
- An external input filter capacitor is required if the module has to meet EN61000-4-4, EN61000-4-5. The QAE100-24SXXW and QAE100-48SXXW recommended 2 pcs of aluminum electrolytic capacitor (Nippon chemi-con KY series, 220µF/100V) to connect in parallel. The QAE100-110SXXW recommended 3 pcs of aluminum electrolytic capacitor (Ruby-con BXF series, 100µF/250V) to connect in parallel.
- BASE-PLATE GROUNDING: When connect two screw bolts to shield plane, the EMI could be reduced.

CAUTION: This power module is not internally fused. An input line fuse must always be used.

CHARACTERISTIC CURVE

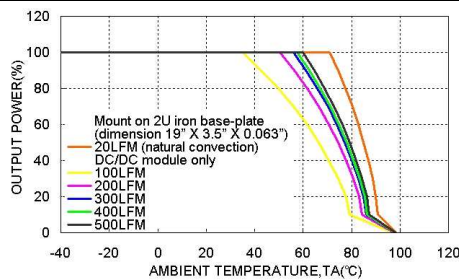

QAE100-24S05W Derating Curve

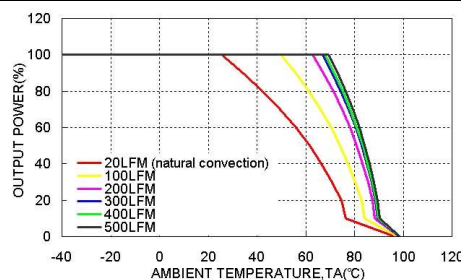

QAE100-24S05W Derating Curve With 0.24" Height Heat-sink

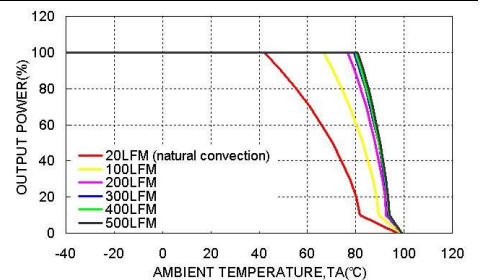

QAE100-24S05W Derating Curve With 0.5" Height Heat-sink

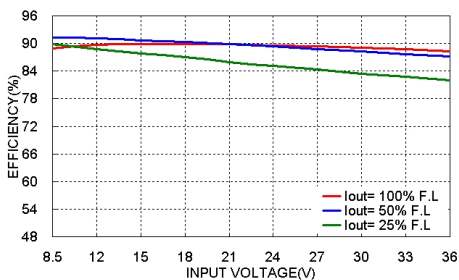

QAE100-24S05W Efficiency vs. Input Voltage

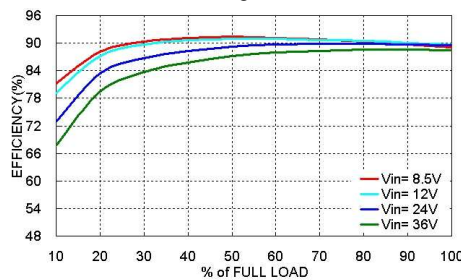

QAE100-24S05W Efficiency vs. Output Load

MECHANICAL DRAWING

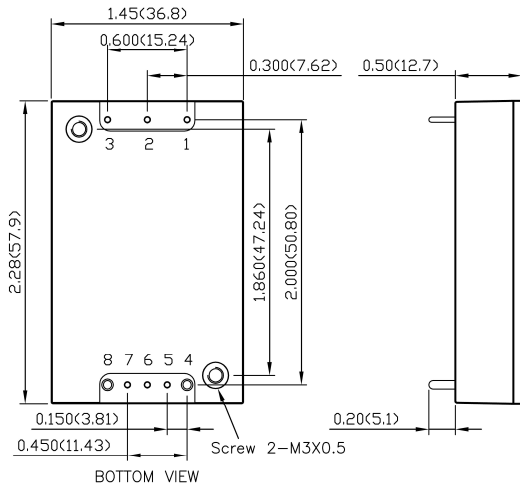

PIN CONNECTION

PIN	DEFINE	DIAMETER
1	- Vin	0.04 Inch
2	Ctrl	0.04 Inch
3	+ Vin	0.04 Inch
4	- Vout	0.06 Inch
5	- Sense	0.04 Inch
6	Trim	0.04 Inch
7	+ Sense	0.04 Inch
8	+ Vout	0.06 Inch

EXTERNAL OUTPUT TRIMMING

Output can be externally trimmed by using the method shown below.

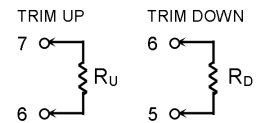

1. All dimensions in inch (mm)
2. Tolerance :x.xx±0.02 (x.x±0.5)
x.xxx±0.01 (x.xx±0.25)
3. Pin pitch tolerance ±0.01 (0.25)
4. Pin dimension tolerance ±0.004(0.1)
5. The screw locked torque:
MAX 3.5kgf-cm (0.34N-m)

$$R_U = \left(\frac{5.11V_{OUT}(100 + \Delta\%)}{1.225\Delta\%} - \frac{(511 + 10.22\Delta\%)}{\Delta\%} \right) k\Omega$$

$$R_D = \left(\frac{511}{\Delta\%} - 10.22 \right) k\Omega$$

HEAT-SINK TYPE OPTIONS

7G-0029A-F

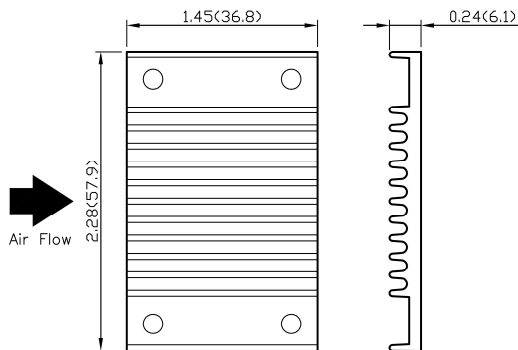

7G-0030A-F

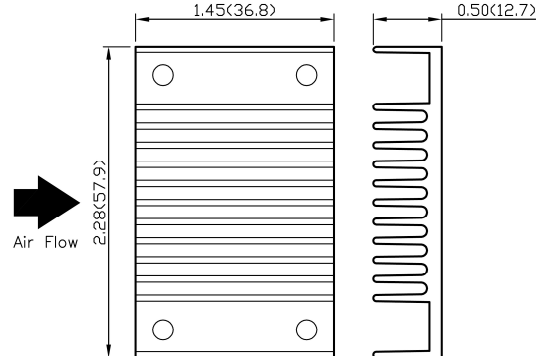

7G-0031A-F

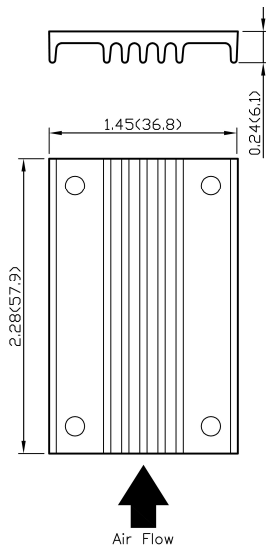

7G-0032A-F

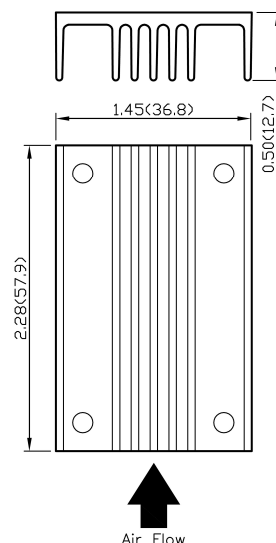

1. All dimensions in inch (mm)
2. Tolerance :x.xx±0.02 (x.x±0.5)