

MME65R280Q

650V 0.28Ω N-channel MOSFET

■ Description

MME65R280Q is power MOSFET using MagnaChip's advanced super junction technology that can realize very low on-resistance and gate charge. It will provide much high efficiency by using optimized charge coupling technology. These user friendly devices give an advantage of low EMI to designers as well as low switching loss.

■ Key Parameters

Parameter	Value	Unit
$V_{DS} @ T_{j, max}$	700	V
$R_{DS(on), max}$	0.28	Ω
$V_{GS(th), typ}$	3	V
I_D	13.8	A
Q_g, typ	27.8	nC

■ Package & Internal Circuit

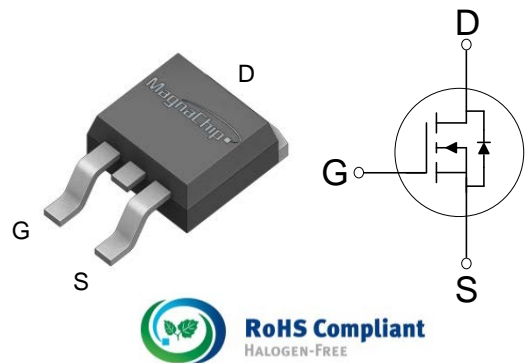

■ Features

- Low power loss by high speed switching and low on-resistance
- 100% avalanche tested
- Green package – Pb-free plating, Halogen-free

■ Applications

- PFC power supply stages
- Switching applications
- Adapter

■ Ordering Information

Order Code	Marking	Temp. Range	Package	Packing	RoHS Status
MME65R280QRH	65R280Q	-55 ~ 150°C	TO-263(D2PAK)	Reel	compliant

■ Absolute Maximum Rating ($T_c=25^\circ\text{C}$ unless otherwise specified)

Parameter	Symbol	Rating	Unit	Note
Drain – Source voltage	V_{DSS}	650	V	
Gate – Source voltage	V_{GSS}	± 30	V	
Continuous drain current	I_D	13.8	A	$T_C = 25^\circ\text{C}$
		8.7	A	$T_C = 100^\circ\text{C}$
Pulsed drain current ⁽¹⁾	I_{DM}	41.4	A	
Power dissipation	P_D	104.2	W	
Single - pulse avalanche energy	E_{AS}	290	mJ	
MOSFET dv/dt ruggedness	dv/dt	50	V/ns	
Diode dv/dt ruggedness ⁽²⁾	dv/dt	15	V/ns	
Storage temperature	T_{stg}	-55 ~150	$^\circ\text{C}$	
Maximum operating junction temperature	T_j	150	$^\circ\text{C}$	

1) I_D limited by maximum junction temperature

2) Pulse width t_P limited by $T_{j,max}$

■ Thermal Characteristics

Parameter	Symbol	Value	Unit
Thermal resistance, junction-case max	R_{thjc}	1.2	$^\circ\text{C/W}$
Thermal resistance, junction-ambient max ⁽³⁾	R_{thja}	62	$^\circ\text{C/W}$

3) Device mounted on minimal footprint of PCB.

■ Static Characteristics ($T_c=25^\circ\text{C}$ unless otherwise specified)

Parameter	Symbol	Min.	Typ.	Max.	Unit	Test Condition
Drain – source breakdown voltage	$V_{(BR)DSS}$	650	-	-	V	$V_{GS} = 0V, I_D = 250\mu A$
Gate threshold voltage	$V_{GS(th)}$	2	3	4	V	$V_{DS} = V_{GS}, I_D = 250\mu A$
Zero gate voltage drain current	I_{DSS}	-	-	1	μA	$V_{DS} = 650V, V_{GS} = 0V$
Gate leakage current	I_{GSS}	-	-	100	nA	$V_{GS} = \pm 30V, V_{DS} = 0V$
Drain-source on state resistance	$R_{DS(ON)}$	-	0.25	0.28	Ω	$V_{GS} = 10V, I_D = 4.4A$

■ Dynamic Characteristics ($T_c=25^\circ\text{C}$ unless otherwise specified)

Parameter	Symbol	Min.	Typ.	Max.	Unit	Test Condition
Input capacitance	C_{iss}	-	1032	-	pF	$V_{DS} = 25V, V_{GS} = 0V, f = 1.0MHz$
Output capacitance	C_{oss}	-	1192	-		
Reverse transfer capacitance	C_{riss}	-	54.8	-		
Effective output capacitance energy related ⁽⁴⁾	$C_{o(er)}$	-	29.3	-		$V_{DS} = 0V \text{ to } 520V, V_{GS} = 0V, f = 1.0MHz$
Turn on delay time	$t_{d(on)}$	-	23.5	-	ns	$V_{GS} = 10V, R_G = 25\Omega, V_{DS} = 325V, I_D = 13.8A$
Rise time	t_r	-	59	-		
Turn off delay time	$t_{d(off)}$	-	151	-		
Fall time	t_f	-	52	-		
Total gate charge	Q_g	-	27.8	-	nC	$V_{GS} = 10V, V_{DS} = 520V, I_D = 13.8A$
Gate – source charge	Q_{gs}	-	9.9	-		
Gate – drain charge	Q_{gd}	-	7.1	-		
Gate resistance	R_G	-	21	-	Ω	$V_{GS} = 0V, f = 1.0MHz$

4) $C_{o(er)}$ is a capacitance that gives the same stored energy as C_{oss} while V_{DS} is rising from 0V to 80% $V_{(BR)DSS}$

■ Reverse Diode Characteristics ($T_c=25^{\circ}\text{C}$ unless otherwise specified)

Parameter	Symbol	Min.	Typ.	Max.	Unit	Test Condition
Continuous diode forward current	I_S	-	-	13.8	A	
Diode forward voltage	V_{SD}	-	-	1.4	V	$I_S = 13.8\text{A}$, $V_{GS} = 0\text{V}$
Reverse recovery time	t_{rr}	-	377	-	ns	$I_S = 13.8\text{A}$ $di/dt = 100\text{A}/\mu\text{s}$ $V_{DD} = 100\text{V}$
Reverse recovery charge	Q_{rr}	-	5.2	-	μC	
Reverse recovery current	I_{rrm}	-	27.6	-	A	

■ Characteristic Graph

Fig.1 Output characteristics.

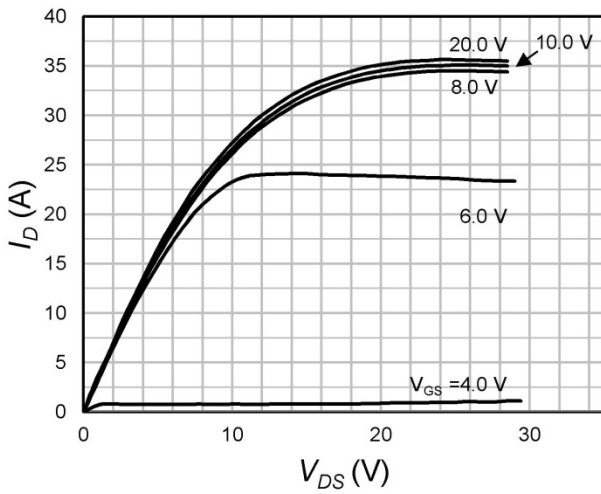

Fig.2 Drain-source on-state resistance vs. drain current

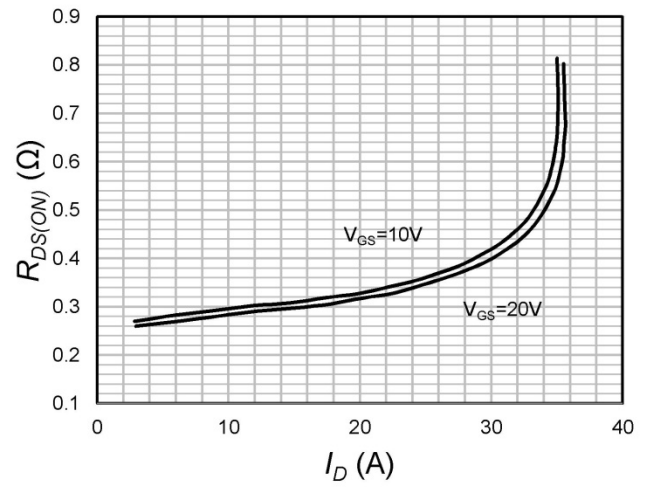

Fig.3 Drain-source on-state resistance (normalized)

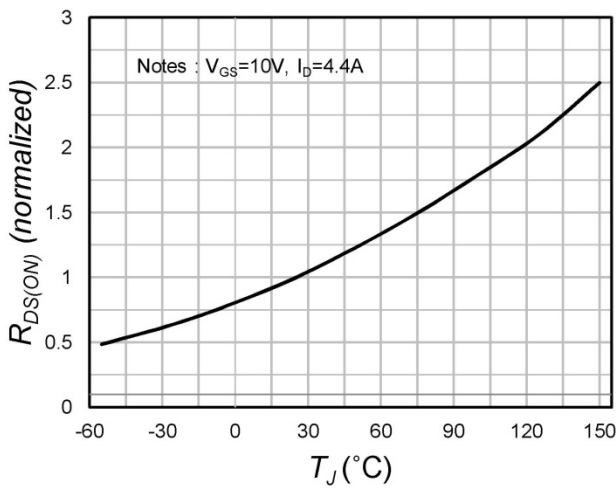

Fig.4 Drain-source breakdown voltage (normalized)

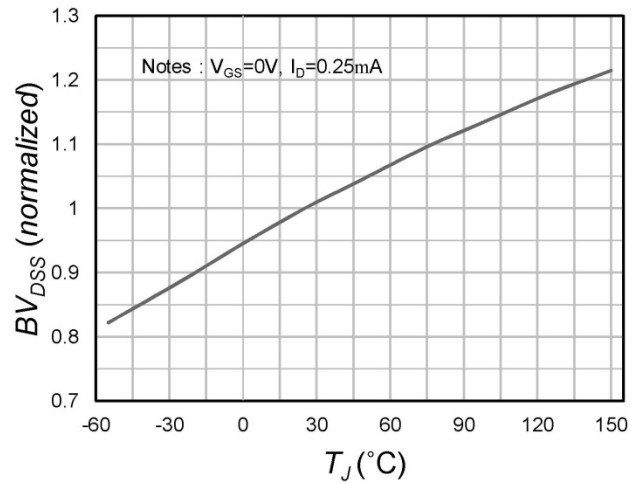

Fig.5 Transfer characteristics

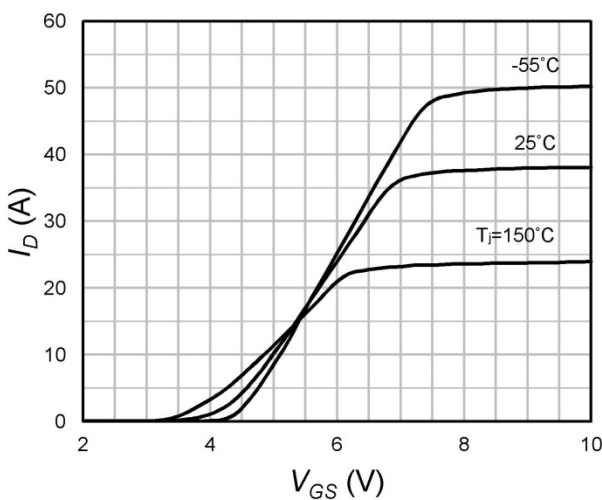

Fig.6 Forward characteristics of reverse diode

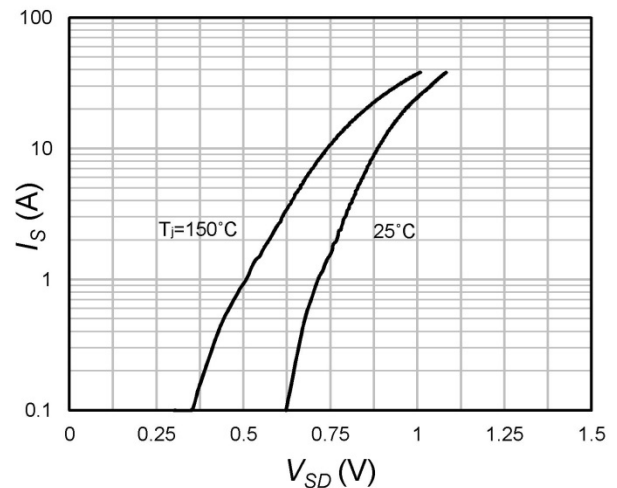

Fig.7 Gate charge

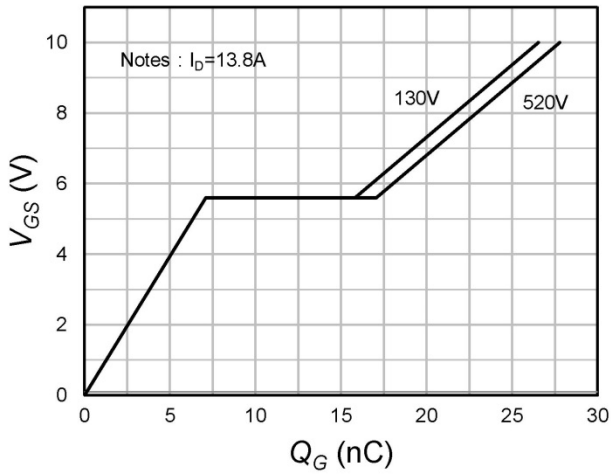

Fig.8 Capacitances

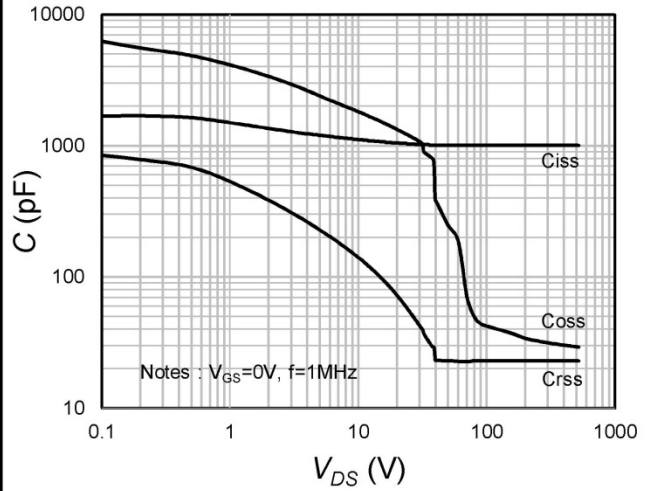

Fig.9 VGS(th) variation vs. temperature (normalized)

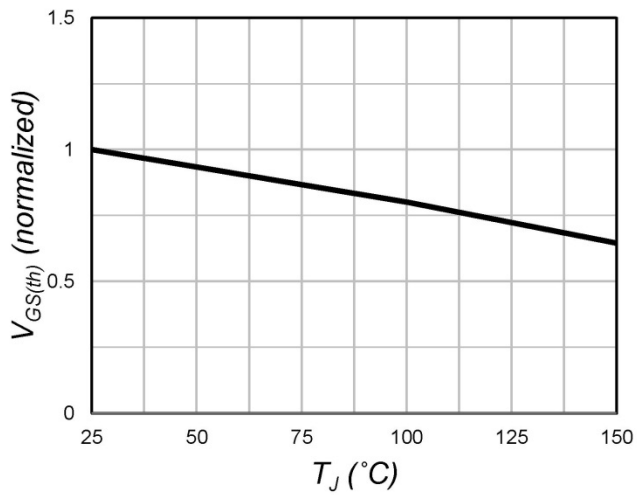

Fig.10 Maximum drain current vs. case temperature

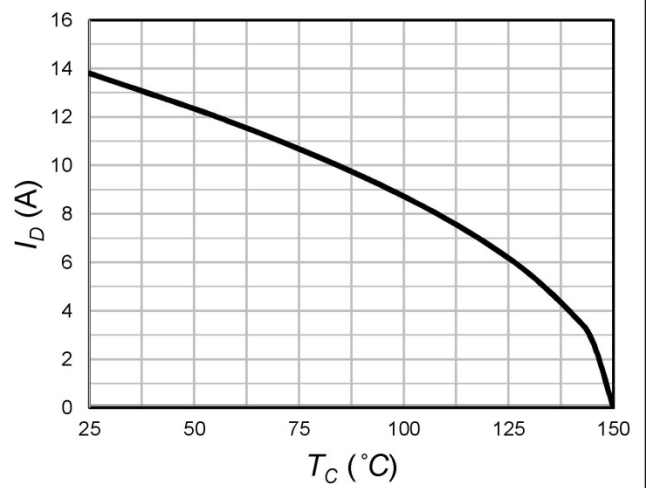

Fig.11 Power dissipation

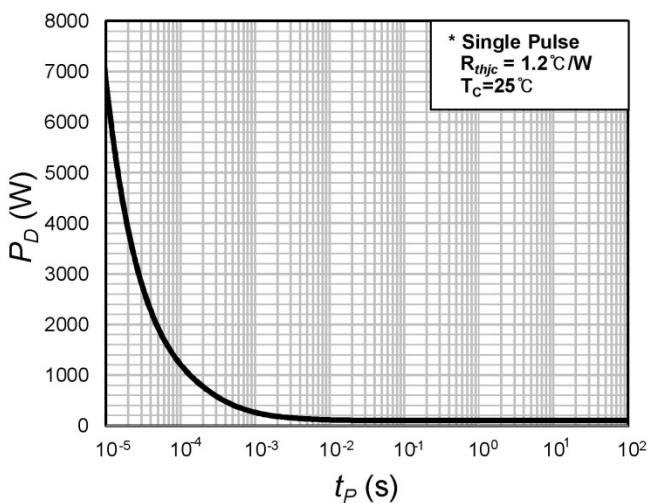

Fig.12 Output capacitance stored energy

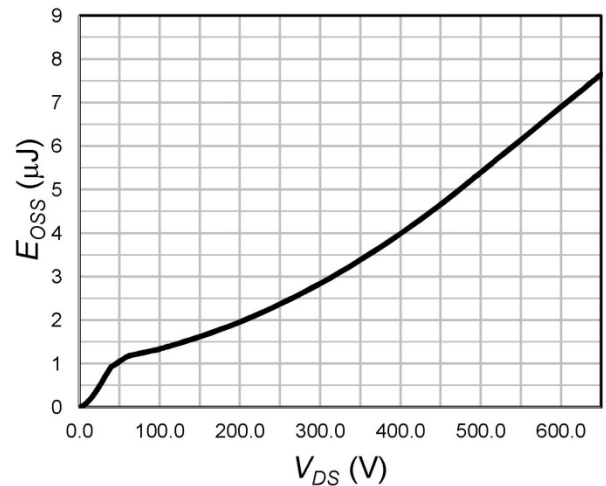

Fig.13 Transient thermal impedance

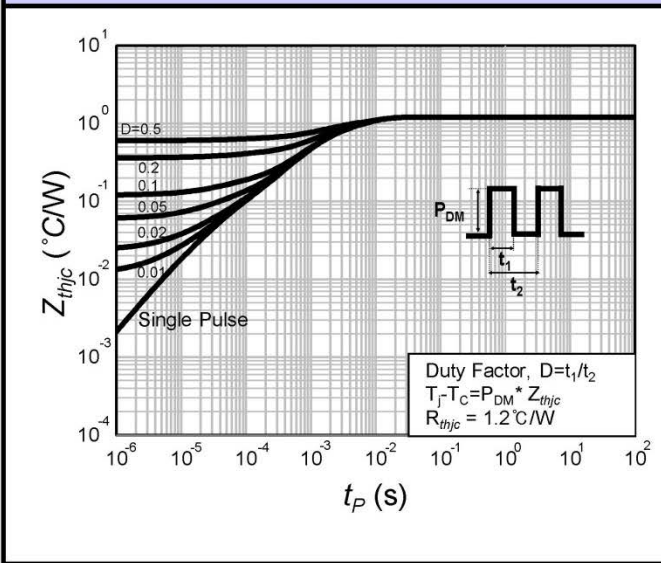
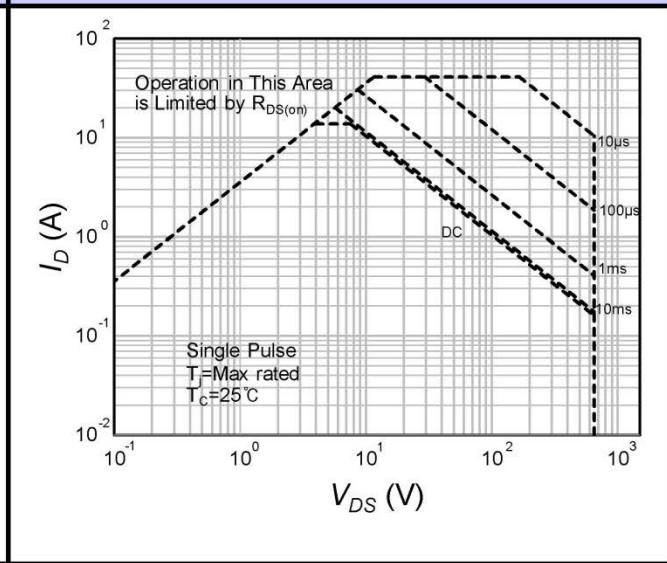

Fig.14 Safe operating area



■ Test Circuit

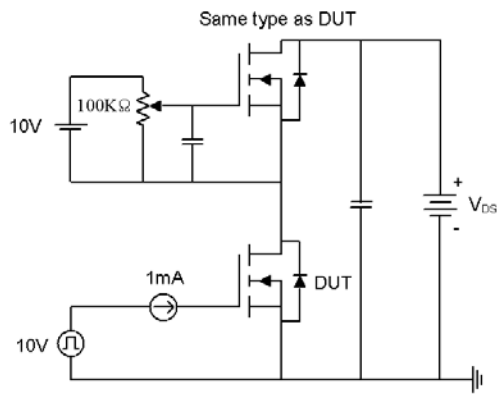

Fig15-1. Gate charge measurement circuit

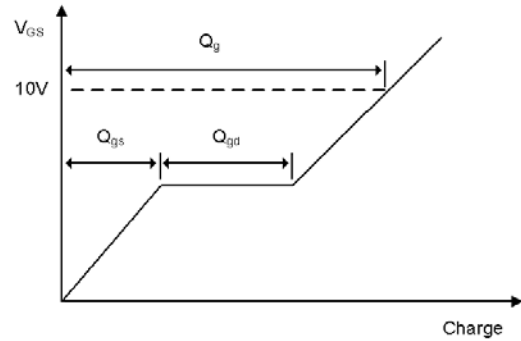

Fig15-2. Gate charge waveform

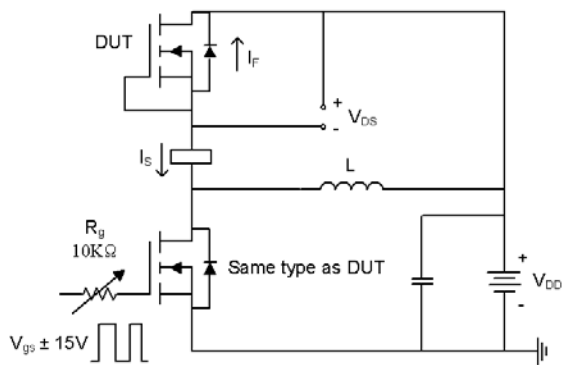

Fig16-1. Diode reverse recovery test circuit

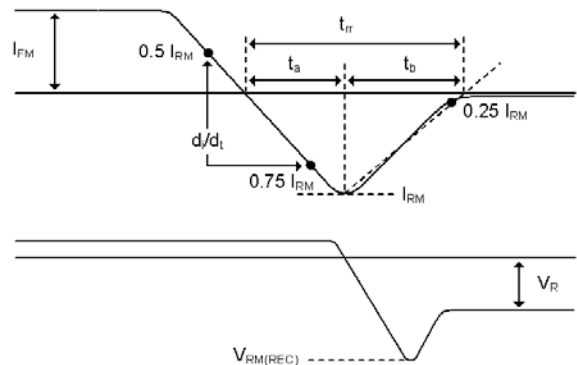

Fig16-2. Diode reverse recovery test waveform

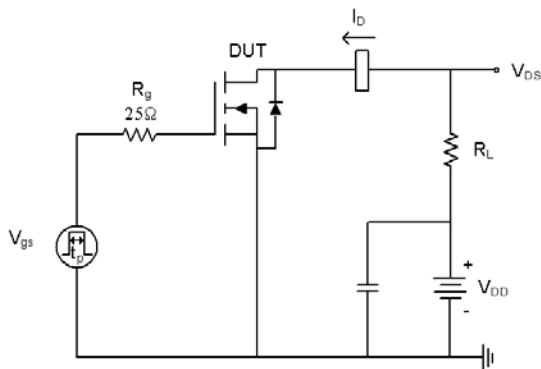

Fig17-1. Switching time test circuit for resistive load

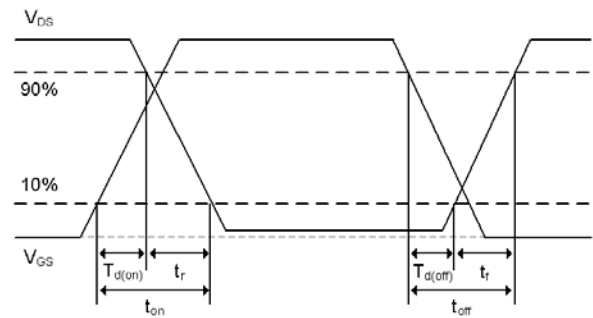

Fig17-2. Switching time waveform

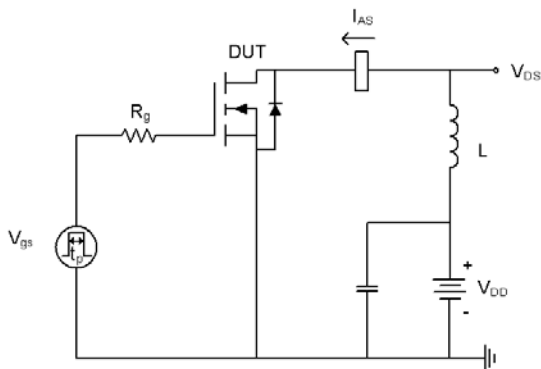

Fig18-1. Unclamped inductive load test circuit

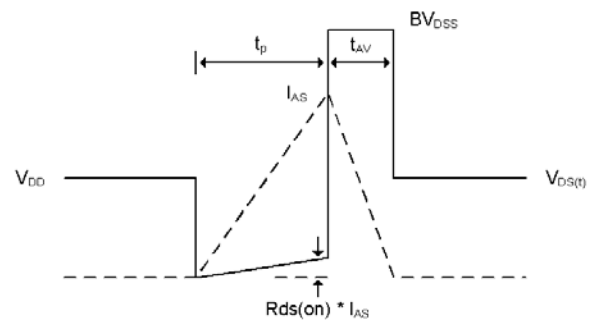
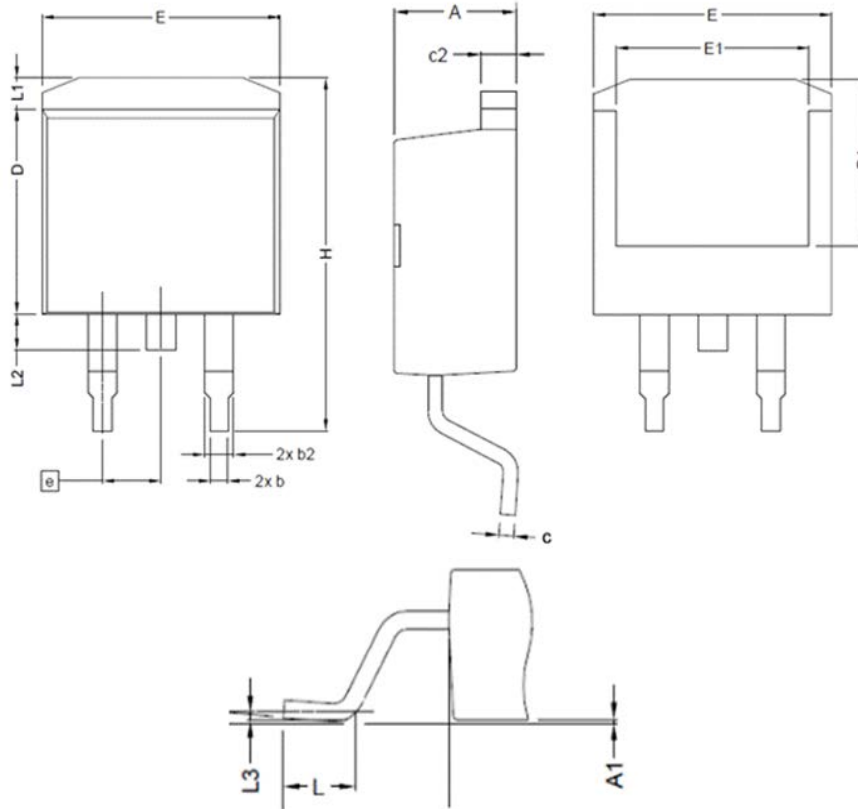

Fig18-2. Unclamped inductive waveform

■ Physical Dimension

TO-263(D2PAK)



[Unit:mm]

Symbol	Millimeters(mm)	
	Min	Max
A	4.064	4.826
A1	-	0.254
b	0.508	0.99
b2	1.140	1.778
c	0.310	0.736
c2	1.140	1.650
D	8.382	9.652
D1	6.6	-
E	9.652	10.668
E1	6.223	-
e	BSC 2.54	
H	14.605	15.875
L	1.778	2.794
L1	-	1.676
L2	-	1.778
L3	BSC 0.254	

DISCLAIMER:

The Products are not designed for use in hostile environments, including, without limitation, aircraft, nuclear power generation, medical appliances, and devices or systems in which malfunction of any Product can reasonably be expected to result in a personal injury. Seller's customers using or selling Seller's products for use in such applications do so at their own risk and agree to fully defend and indemnify Seller.

MagnaChip reserves the right to change the specifications and circuitry without notice at any time. MagnaChip does not consider responsibility for use of any circuitry other than circuitry entirely included in a MagnaChip product.  is a registered trademark of MagnaChip Semiconductor Ltd.