

LM84

LM84 Diode Input Digital Temperature Sensor with Two-Wire Interface



Literature Number: SNIS108B

LM84

Diode Input Digital Temperature Sensor with Two-Wire Interface

General Description

The LM84 is a remote diode temperature sensor, Delta-Sigma analog-to-digital converter, and digital over-temperature detector with an SMBus™ interface. The LM84 senses its own temperature as well as the temperature of a target IC with a diode junction, such as a Pentium® II processor or a diode connected 2N3904. A diode junction (semiconductor junction) is required on the target IC's die. A host can query the LM84 at any time to read the temperature of this diode as well as the temperature state of the LM84 itself. A T_CRIT_A interrupt output becomes active when the temperature is greater than a programmable comparator limit, T_CRIT .

The host can program as well as read back the state of the T_CRIT register. Three state logic inputs allow two pins ($ADD0$, $ADD1$) to select up to 9 SMBus address locations for the LM84. The sensor powers up with default thresholds of 127°C for T_CRIT .

Features

- Directly senses die temperature of remote ICs
- Senses temperature of remote diodes
- SMBus compatible interface, supports SMBus Timeout

- Register readback capability
- 7 bit plus sign temperature data format
- 2 address select lines enable 9 LM84s to be connected to a single bus

Key Specifications

■ Supply Voltage	3.0V - 3.6V
■ Supply Current	1 mA (max)
■ Local Temperature Accuracy	$\pm 1.0^{\circ}\text{C}$ (typ)
■ Remote Diode Temperature Accuracy	
+60°C to +100°C	$\pm 3^{\circ}\text{C}$ (max)
0°C to +125°C	$\pm 5^{\circ}\text{C}$ (max)

Applications

- System Thermal Management
- Personal Computers
- Electronic Test Equipment
- Office Electronics
- HVAC

Simplified Block Diagram

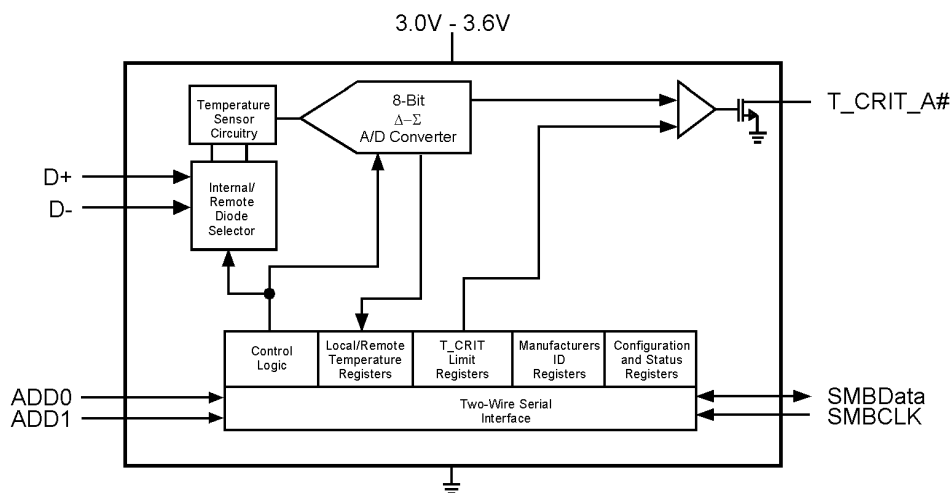

Indicates Active Low ("NOT")

DS100961-1

SMBus™ is a trademark of the Intel Corporation.
 Pentium® II processor is a registered trademark of the Intel Corporation.
 i2C® is a registered trademark of the Philips Corporation.

Connection Diagram

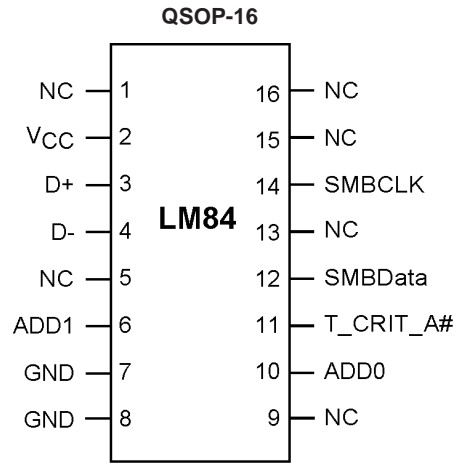

DS100961-2

TOP VIEW

Ordering Information

Order Number	NS Package Number	Transport Media	SMBus Revision Level	Noise Filter on SMBCLK
LM84BIMQA	MQA16A (QSOP-16)	95 Units in Rail	1.1	20MHz
LM84BIMQAX	MQA16A (QSOP-16)	2500 Units on Tape and Reel	1.1	20MHz
LM84CIMQA	MQA16A (QSOP-16)	95 Units in Rail	1.0	Not Available
LM84CIMQAX	MQA16A (QSOP-16)	2500 Units on Tape and Reel	1.0	Not Available

Typical Application

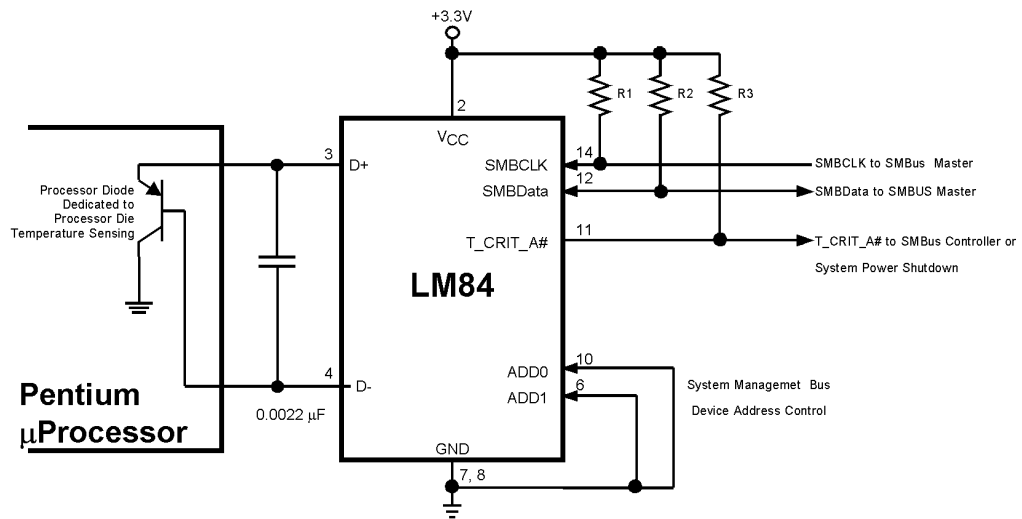

DS100961-3

Pin Descriptions

Label	Pin #	Function	Typical Connection
NC	1, 5, 9, 13, 16	Manufacturing test pins.	Left floating. PC board traces may be routed through the pads for these pins. Although, the components that drive these traces should share the same supply as the LM84 so that the Absolute Maximum Voltage at any Pin rating is not violated.
V _{CC}	2	Positive Supply Voltage Input	DC Voltage from 3.0V to 3.6V
D+	3	Diode Current Source	To Diode Anode. Connected to remote discrete diode or to the diode on the external IC whose die temperature is being sensed.
D-	4	Diode Return Current Sink	To Diode Cathode. Must be grounded when not used.
ADD0-ADD1	10, 6	User-Set SMBus (I ² C) Address Inputs	Ground (Low, "0"), V _{CC} (High, "1") or open ("TRI-LEVEL")
GND	7, 8	Power Supply Ground	Ground
$\overline{T_CRIT_A}$	11	Critical Temperature Alarm, open-drain output	Pull Up Resistor, Controller Interrupt Line or System Shutdown
SMBData	12	SMBus (I ² C) Serial Bi-Directional Data Line, open-drain output	From and to Controller, Pull Up Resistor
SMBCLK	14	SMBus (I ² C) Clock Input	From Controller
NC	15	No Connection	Left floating. PC board traces may be routed through the pads for this pin.

Absolute Maximum Ratings (Note 1)

Supply Voltage	-0.3V to 6.0V
Voltage at Any Pin:	
NC (Pins 1,5,9), ADD0, ADD1, D ⁺	-0.3V to (V _{CC} + 0.3V)
All other pins (except D-)	-0.3V to 6.0V
D- Input Current	±1 mA
Input Current at All Other Pins (Note 2)	5 mA
Package Input Current (Note 2)	20 mA
SMBData, T_CRIT_A Output Sink Current	10 mA
Output Voltage	6.0V
Storage Temperature	-65°C to +150°C

Soldering Information, Lead Temperature

QSOP Package (Note 3)

Vapor Phase (60 seconds) 215°C

Infrared (15 seconds) 220°C

ESD Susceptibility (Note 4)

Human Body Model 2500V

Machine Model 250V

Operating Ratings

(Note 1) and (Note 5)

Specified Temperature Range

T_{MIN} to T_{MAX}

LM84

0°C to +125°C

Supply Voltage Range (V_{CC})

+3.0V to +3.6V

Temperature-to-Digital Converter Characteristics

Unless otherwise noted, these specifications apply for V_{CC}=+3.0 Vdc to +3.6 Vdc. **Boldface limits apply for T_A = T_J = T_{MIN} to T_{MAX}**; all other limits T_A = T_J = +25°C, unless otherwise noted.

Parameter	Conditions	Typical (Note 6)	Limits (Note 7)	Units (Limit)
Local Temperature Error (Note 8)		±1		°C
Remote Temperature Error using Pentium Diode (Note 8) and (Note 9)	+60°C ≤ T _A ≤ +100°C, V _{CC} = 3.3 Vdc		±3	°C (max)
	0°C ≤ T _A ≤ +125°C, V _{CC} = 3.3 Vdc		±5	°C (max)
Remote Temperature Error using Diode Connected 2N3904 (Note 8) and (Note 9)	+60°C ≤ T _A ≤ +100°C, V _{CC} = 3.3 Vdc		+1, -5	°C (max)
	0°C ≤ T _A ≤ +125°C, V _{CC} = 3.3 Vdc		+3, -7	°C (max)
Resolution		8		Bits
		1		°C
Temperature Conversion Time	(Note 11)	120	145	ms
Quiescent Current (Note 10)	SMBus (I ² C Inactive)	0.500	1	mA (max)
D- Source Voltage		0.7		V
Diode Source Current	(D+ - D-) = + 0.65V; high level		160	µA (max)
			50	µA (min)
	Low level		16	µA (max)
			5	µA (min)
T_CRIT_A Output Saturation Voltage	I _{OUT} = 3.0 mA		0.4	V (max)
Power-On Reset Threshold	On V _{CC} input, falling edge		2.2	V (max)
			1.2	V (min)
Local and Remote T_CRIT Default Temperature	(Note 12)	+127		°C

Logic Electrical Characteristics

DIGITAL DC CHARACTERISTICS

Unless otherwise noted, these specifications apply for $V_{CC}=+3.0$ to 3.6 Vdc. **Boldface limits apply for $T_A = T_J = T_{MIN}$ to T_{MAX}** ; all other limits $T_A = T_J = +25^\circ\text{C}$, unless otherwise noted.

Symbol	Parameter	Conditions	Typical (Note 6)	LM84B Limits (Note 7)	LM84C Limits (Note 7)	Units (Limit)
SMBData, SMBCLK						
$V_{IN(1)}$	Logical "1" Input Voltage			2.1	1.4	V (min)
$V_{IN(0)}$	Logical "0" Input Voltage			0.8	0.6	V (max)
$I_{IN(1)}$	Logical "1" Input Current	$V_{IN} = V_{CC}$	0.005	1.0	1.0	μA (max)
$I_{IN(0)}$	Logical "0" Input Current	$V_{IN} = 0\text{V}$	-0.005	-1.0	-1.0	μA (max)
ADD0, ADD1						
$V_{IN(1)}$	Logical "1" Input Voltage		V_{CC}	1.6	1.6	V (min)
$V_{IN(0)}$	Logical "0" Input Voltage		GND	0.5	0.5	V (max)
$I_{IN(1)}$	Logical "1" Input Current	$V_{IN} = V_{CC}$	50	600	600	μA (max)
$I_{IN(0)}$	Logical "0" Input Current	$V_{IN} = 0\text{V}$	50	600	600	μA (max)
ALL DIGITAL INPUTS						
C_{IN}	Input Capacitance		20			pF
ALL DIGITAL OUTPUTS						
I_{OH}	High Level Output Current	$V_{OH} = V_{CC}$		100	100	μA (max)
V_{OL}	SMBus Low Level Output Voltage	$I_{OL} = 3\text{ mA}$ $I_{OL} = 6\text{ mA}$		0.4 0.6	0.4 0.6	V (max)

Logic Electrical Characteristics (Continued)

SMBus DIGITAL SWITCHING CHARACTERISTICS

Unless otherwise noted, these specifications apply for $V_{CC}=+3.0$ Vdc to $+3.6$ Vdc, C_L (load capacitance) on output lines = 80 pF. **Boldface limits apply for $T_A = T_J = T_{MIN}$ to T_{MAX}** ; all other limits $T_A = T_J = +25^\circ\text{C}$, unless otherwise noted.

The switching characteristics of the LM84 fully meet or exceed the published specifications of the SMBus or I²C bus. The following parameters are the timing relationships between SMBCLK and SMBData signals related to the LM84. They are not necessarily the I²C or SMBus bus specifications.

Symbol	Parameter	Conditions	Typical (Note 6)	Limits (Note 7)	Units (Limit)
f_{SMB}	SMBus Clock Frequency			400 10	kHz (max) kHz (min)
t_{LOW}	SMBus Clock Low Time	10% to 10%		1.3 25	μs (min) ms (max)
$t_{LOWSEXT}$	Cumulative Clock Low Extend Time			25	ms (max)
t_{HIGH}	SMBus Clock High Time	90% to 90%		0.6	μs (min)
$t_{R;SMB}$	SMBus Rise Time	10% to 90%	1		μs
$t_{F;SMB}$	SMBus Fall Time	90% to 10%	0.3		μs
t_{OF}	Output Fall Time	$C_L = 400$ pF $I_O = 3$ mA		250	ns (max)
$t_{TIMEOUT}$	SMBData and SMBCLK Time Low for Reset of Serial Interface (Note 13)			25 40	ms (min) ms (max)
t_1	SMBCLK (Clock) Period			2.5	μs (min)
$t_2,$ $t_{SU;DAT}$	Data In Setup Time to SMBCLK High			100	ns (min)
$t_3,$ $t_{HD;DAT}$	Data Out Stable after SMBCLK Low			0 0.9	ns (min) μs (max)
$t_4,$ $t_{HD;STA}$	SMBData Low Setup Time to SMBCLK Low			100	ns (min)
$t_5,$ $t_{SU;STO}$	SMBData High Delay Time after SMBCLK High (Stop Condition Setup)			100	ns (min)
$t_6,$ $t_{SU;STA}$	SMBus Start-Condition Setup Time			0.6	μs (min)
t_{BUF}	SMBus Free Time			1.3	μs (min)

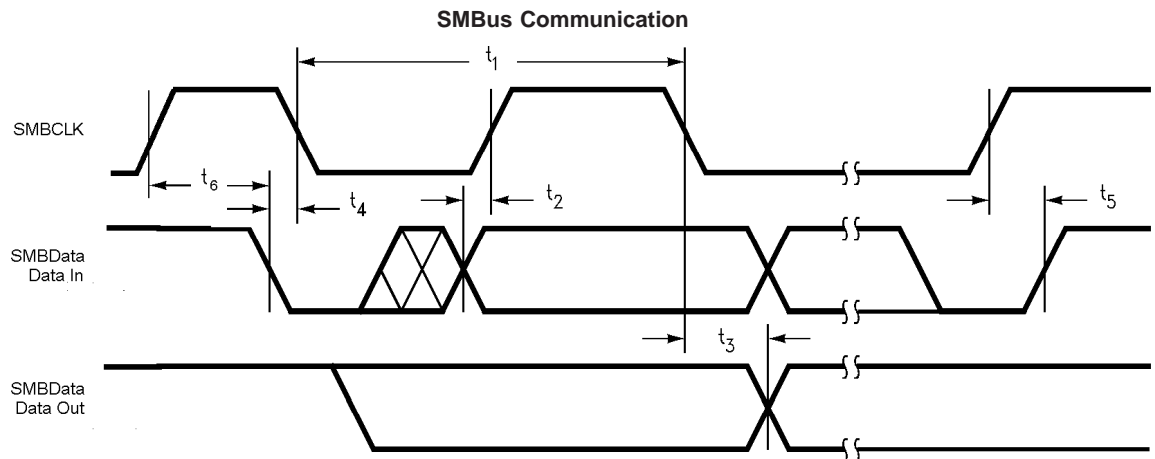

Logic Electrical Characteristics (Continued)

SMBus TIMEOUT

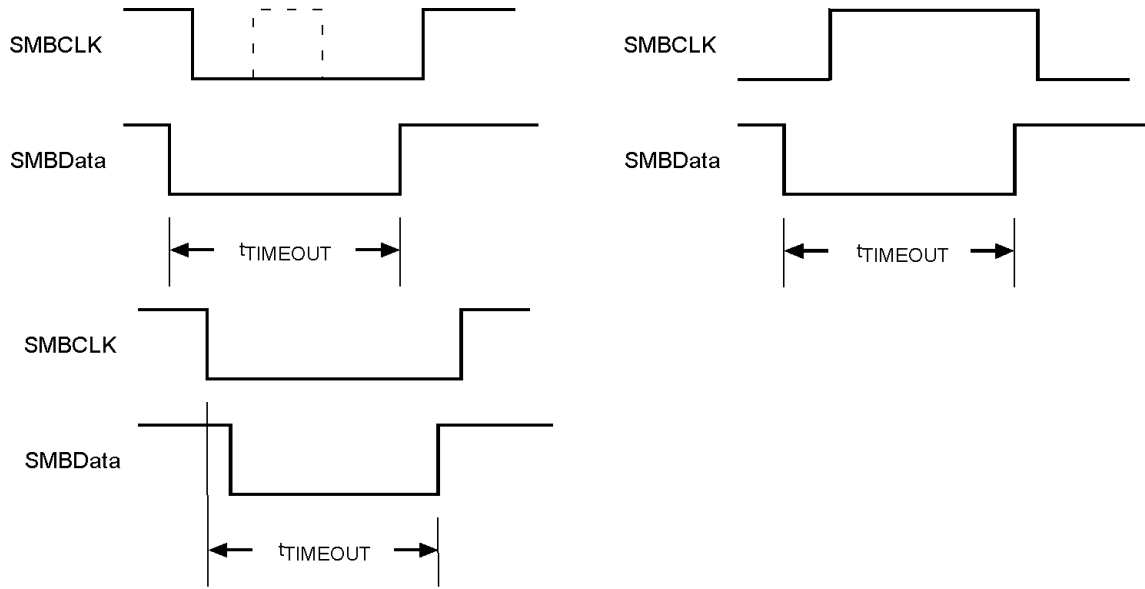

DS100961-13

Logic Electrical Characteristics (Continued)

Note 1: Absolute Maximum Ratings indicate limits beyond which damage to the device may occur. DC and AC electrical specifications do not apply when operating the device beyond its rated operating conditions.

Note 2: When the input voltage (V_I) at any pin exceeds the power supplies ($V_I < \text{GND}$ or $V_I > V_{CC}$), the current at that pin should be limited to 5 mA. The 20 mA maximum package input current rating limits the number of pins that can safely exceed the power supplies with an input current of 5 mA to four.

Parasitics and/or ESD protection circuitry are shown in the figure below for the LM84's pins. The nominal breakdown voltage of the zener D3 is 6.5V. Care should be taken not to forward bias the parasitic diode, D1, present on pins: NC pins 1,5 and 9, D+, ADD1 and ADD0. Doing so by more than 50 mV may corrupt a temperature or voltage measurement.

Pin Name	D1	D2	D3	D4	Pin Name	D1	D2	D3	D4
NC (pins 1, 5, 9)	x	x	x		$\overline{\text{T_CRIT_A}}$		x		
V_{CC}			x		SMBData		x	x	
D+	x	x	x		NC (pin 13)		x	x	
D-		x	x	x	SMBCLK			x	
ADD0, ADD1	x	x	x		NC (pin 16)		x		

Note: An x indicates that the diode exists.

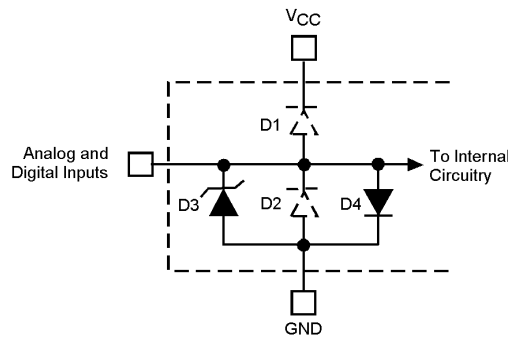

DS100961-8

FIGURE 1. ESD Protection Input Structure

Note 3: See AN-450 "Surface Mounting Methods and Their Effect on Product Reliability" or the section titled "Surface Mount" found in a current National Semiconductor Linear Data Book for other methods of soldering surface mount devices.

Note 4: Human body model, 100 pF discharged through a 1.5 k Ω resistor. Machine model, 200 pF discharged directly into each pin.

Note 5: Thermal resistance of the QSOP-16 package is TBD $^{\circ}\text{C}/\text{W}$, junction-to-ambient when attached to a printed circuit board with 2 oz. foil.

Note 6: Typical values are at $T_A = 25^{\circ}\text{C}$ and represent most likely parametric norm.

Note 7: Limits are guaranteed to National's AOQL (Average Outgoing Quality Level).

Note 8: The Temperature Error specification does not include an additional error of $\pm 1^{\circ}\text{C}$, caused by the quantization error.

Note 9: The Temperature Error will vary less than $\pm 1.0^{\circ}\text{C}$ for a variation in V_{CC} of 3V to 3.6V from the nominal of 3.3V.

Note 10: Quiescent current will not increase substantially with an active SMBus.

Note 11: This specification is provided only to indicate how often temperature data is updated. The LM84 can be read at any time without regard to conversion state (and will yield last conversion result).

Note 12: Default values set at power up.

Note 13: Holding the SMBData and/or SMBCLK lines Low for a time interval greater than t_{TIMEOUT} will cause the LM84 to reset SMBData and SMBCLK to the IDLE state of an SMBus communication (SMBCLK and SMBData set High).

Logic Electrical Characteristics (Continued)

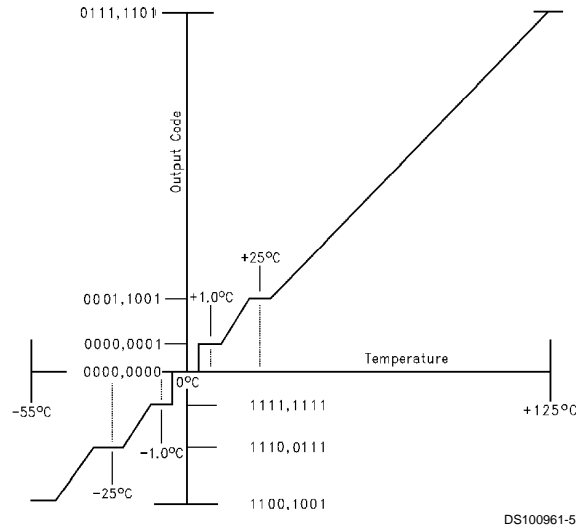

FIGURE 2. Temperature-to-Digital Transfer Function (Non-linear scale for clarity)

1.0 Functional Description

The LM84 temperature sensor incorporates a band-gap type temperature sensor using a Local or Remote diode and an 8-bit ADC (Delta-Sigma Analog-to-Digital Converter). The LM84 is compatible with the serial SMBus and I²C interfaces. Digital comparators compare Local and Remote readings to user-programmable setpoints (LT_CRIT and RT_CRIT). Activation of the $\overline{T_CRIT_A}$ output indicates that a temperature reading is greater than the limit preset in a T_CRIT register.

1.1 $\overline{T_CRIT_A}$ OUTPUT, T_CRIT LIMITS

$\overline{T_CRIT_A}$ is activated when the Local temperature reading is greater than the limit preset in the local critical temperature setpoint register (LT_CRIT) or when the Remote temperature reading is greater than the limit preset in the remote critical temperature setpoint register (RT_CRIT), as shown in Figure 3. The $\overline{T_CRIT_A}$ mask bit (bit 7 of the Configuration Register) when set will disable the $\overline{T_CRIT_A}$ output.

The Status Register can be read to determine which event caused the alarm. A bit in the Status Register is set high to indicate T_CRIT temperature alarm, see Section 1.8.3.

Local and remote temperature diodes are sampled alternately by the A/D converter. The $\overline{T_CRIT_A}$ output and the Status Register flags are updated at the completion of a conversion, which takes approximately 60 ms. $\overline{T_CRIT_A}$ and the Status Register flags are reset only after the Status Register is read and if the temperature is below the setpoint.

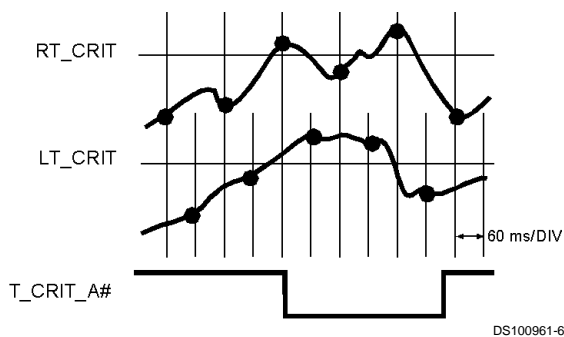

FIGURE 3. $\overline{T_CRIT_A}$ Temperature Response Diagram

1.2 POWER-ON RESET DEFAULT STATES

LM84 always powers up to these known default states:

1. Local Temperature set to 0°C
2. Remote Temperature set to 0°C until the LM84 senses a diode present or open circuit on the D+ and D- input pins.
3. Status Register set to 00h.
4. Command Register set to 00h; $\overline{T_CRIT_A}$ enabled.
5. Local and Remote T_CRIT set to 127°C

1.0 Functional Description (Continued)

1.3 SMBus INTERFACE

The LM84 operates as a slave on the SMBus, so the SMBCLK line is an input (no clock is generated by the LM84) and the SMBData line is bi-directional. According to SMBus specifications, the LM84 has a 7-bit slave address. Bit 4 (A3) of the slave address is hard wired inside the LM84 to a 1. The remainder of the address bits are controlled by the address select pins ADD1 and ADD0, and are set by connecting these pins to ground for a low, (0), to V_{CC} for a high, (1), or left floating (TRI-LEVEL).

Therefore, the complete slave address is:

A6	A5	A4	A3	A2	A1	A0
MSB						LSB

and is selected as follows:

Address Select Pin State		LM84 SMBus Slave Address
ADD0	ADD1	A6:A0 binary
0	0	001 1000
0	TRI-LEVEL	001 1001
0	1	001 1010
TRI-LEVEL	0	010 1001
TRI-LEVEL	TRI-LEVEL	010 1010
TRI-LEVEL	1	010 1011
1	0	100 1100
1	TRI-LEVEL	100 1101
1	1	100 1110

The LM84 latches the state of the address select pins during the first read or write on the SMBus. Changing the state of the address select pins after the first read or write to any device on the SMBus will not change the slave address of the LM84.

1.4 TEMPERATURE DATA FORMAT

Temperature data can be read from the Local Temperature, Remote Temperature, and T_CRIT setpoint registers. Temperature data can only be written to the T_CRIT setpoint registers. Temperature data is represented by an 8-bit, two's complement byte with an LSB (Least Significant Bit) equal to 1°C:

Temperature	Digital Output	
	Binary	Hex
+125°C	0111 1101	7Dh
+25°C	0001 1001	19h
+1°C	0000 0001	01h
0°C	0000 0000	00h
-1°C	1111 1111	FFh
-25°C	1110 0111	E7h
-55°C	1100 1001	C9h

1.5 OPEN-DRAIN OUTPUTS

SMBData and \bar{T}_{CRIT_A} outputs are open-drain and do not have internal pull-ups. A "high" level will not be observed on these pins until pull-up current is provided from some external source, typically a pull-up resistor. Choice of resistor value depends on many system factors but, in general, the pull-up resistor should be as large as possible. This will

minimize any local temperature reading errors due to self heating of the LM84. The maximum resistance of the pull-up, based on LM84 specification for High Level Output Current, to provide a 2V high level, is 30 k Ω .

1.6 DIODE FAULT DETECTION

Before each remote conversion the LM84 goes through an external diode fault detection sequence. If the D+ input is shorted to V_{CC} or floating then the temperature reading will be +127°C, bit 2 (OPEN) of the Status Register will be set. If the Remote T_CRIT setpoint is set to less than +127°C then bit 4 (RTCRIT) of the Status Register will be set which will activate the \bar{T}_{CRIT_A} output, if enabled. If D+ is shorted to GND or D-, the temperature reading will be 0°C and bit 2 of the Status Register will not be set.

1.0 Functional Description (Continued)

1.7 COMMUNICATING with the LM84

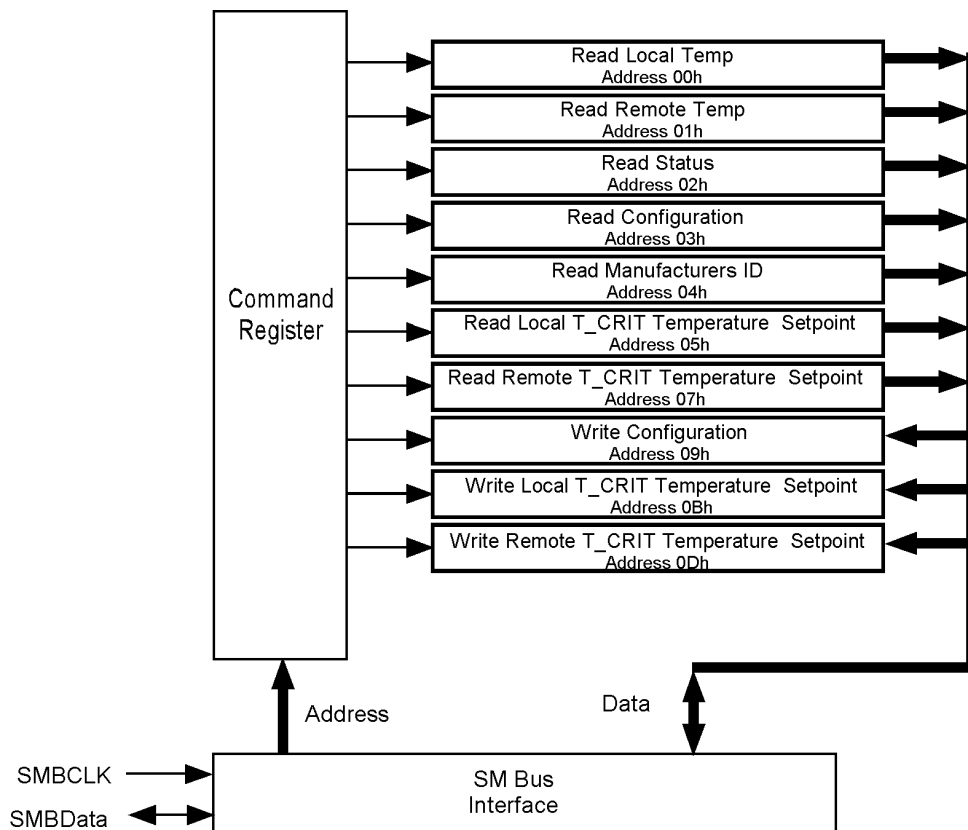

DS100961-9

There are 10 data registers in the LM84, selected by the Command Register. At power-up the Command Register is set to "00", the location for the Read Local Temperature Register. The Command Register latches whatever the last location it was set to. Reading the Status Register resets T_CRIT_A. All registers are predefined as read only or write only. Read and write registers with the same function contain mirrored data.

A **Write** to the LM84 will always include the address byte and the command byte. A write to any register requires one data byte.

Reading the LM84 can take place either of two ways:

1. If the location latched in the Command Register is correct (most of the time it is expected that the Command Register will point to one of the Read Temperature Registers because that will be the data most frequently read from the LM84), the read can simply consist of an address byte, followed by retrieving the data byte.
2. If the Command Register needs to be set, then an address byte, command byte, repeat start, and another address byte will accomplish a read.

The data byte has the most significant bit first. At the end of a read, the LM84 can accept either Acknowledge or No Acknowledge from the Master (No Acknowledge is typically used as a signal for the slave that the Master has read its last byte).

1.7.1 SMBus TIMEOUT

The LM84 SMBus interface circuitry will be reset to the SMBus idle state if the SMBData or SMBCLK lines are held low for more than 40 ms. The LM84 may or may not reset the state SMBData or SMBCLK if either of these lines are held low between 25 ms and 40 ms. Holding SMBData or SMBCLK low for less than or equal to 25 ms will not reset the interface circuitry. The LM84 has a built-in internal timer to guarantee that the interface is reset if the SMBData line were to get stuck low. This can commonly occur when the master is reset while the slave is transmitting low. This enhancement to the SMBus TIMEOUT specification ensures error free performance even in remote systems where complete power supply shutdown, for reset, is a nuisance. This would have to occur since many cost effective temperature sensors such as the LM84 do not have a pin dedicated for reset.

1.0 Functional Description (Continued)

1.8 LM84 REGISTERS

1.8.1 COMMAND REGISTER

Selects which registers will be read from or written to. Data for this register should be transmitted during the Command Byte of the SMBus write communication.

P7	P6	P5	P4	P3	P2	P1	P0
0	0	0	0	Command Select			

P0-P7: Command Select:

Command Select Address	Power On Default State		Register Name	Register Function
	<P7:P0> hex	<D7:D0> binary		
00h	0000 0000	0	RLT	Read Local Temperature
01h	0000 0000	0	RRT	Read Remote Temperature
02h	0000 0000	0	RS	Read Status
03h	0000 0000	0	RC	Read Configuration
04h	0000 0000	0	RMID	Manufacturers ID
05h	0111 1111	127	RLCS	Read Local T_CRIT Setpoint
07h	0111 1111	127	RRCS	Read Remote T_CRIT Setpoint
09h	0000 0000	0	WC	Write Configuration
0Bh	0111 1111	127	WLCS	Write Local T_CRIT Setpoint
0Dh	0111 1111	127	WRCS	Write Remote T_CRIT Setpoint

1.8.2 LOCAL and REMOTE TEMPERATURE REGISTERS

(Read Only Address 00h and 01h):

D7	D6	D5	D4	D3	D2	D1	D0
MSB	Bit 6	Bit 5	Bit 4	Bit 3	Bit 2	Bit 1	LSB

D7–D0: Temperature Data. One LSB = 1°C. Two's complement format.

1.8.3 STATUS REGISTER

(Read Only Address 02h):

D7	D6	D5	D4	D3	D2	D1	D0
0	LTCRIT	0	RTCRIT	0	OPEN	0	0

Power up default is with all bits "0" (zero).

D2: OPEN: When set to 1 indicates a Remote Diode disconnect.

D4: RTCRIT: When set to 1 indicates an RT_CRIT alarm.

D6: LTCRIT: When set to 1 indicates an LT_CRIT alarm.

D7, D5, D3, D1–D0: These bits are always set to 0.

1.8.4 Manufacturers ID Register

(Read Address 04h) Default value 00h.

1.8.5 CONFIGURATION REGISTER

(Read Address 03h /Write Address 09h):

D7	D6	D5	D4	D3	D2	D1	D0
$\overline{T_CRIT_A}$ mask	0	0	0	0	0	0	0

Power up default is with all bits "0" (zero).

D7: $\overline{T_CRIT_A}$ mask: When set to 1 $\overline{T_CRIT_A}$ interrupts are masked.

D6–D0: These bits are always set to 0. A write of 1 will return a 0 when read.

1.0 Functional Description (Continued)

1.8.6 LOCAL AND REMOTE T_CRIT REGISTERS

(Read/Write):

D7	D6	D5	D4	D3	D2	D1	D0
MSB	Bit 6	Bit 5	Bit 4	Bit 3	Bit 2	Bit 1	LSB

D7–D0: RT_CRIT and LT_CRIT setpoint temperature data. Power up default is LT_CRIT = RT_CRIT = 127°C.

2.0 SMBus Timing Diagrams

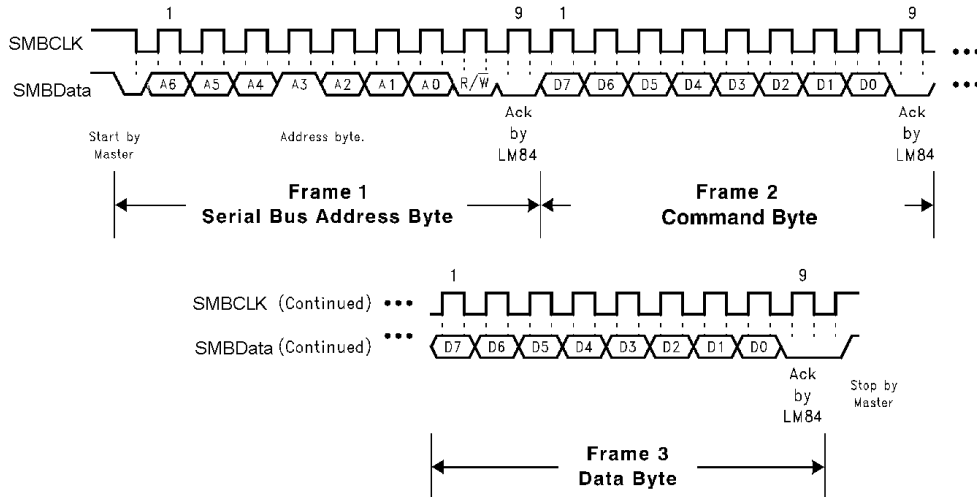

DS100961-10

(a) Serial Bus Write to the internal Command Register followed by a the Data Byte

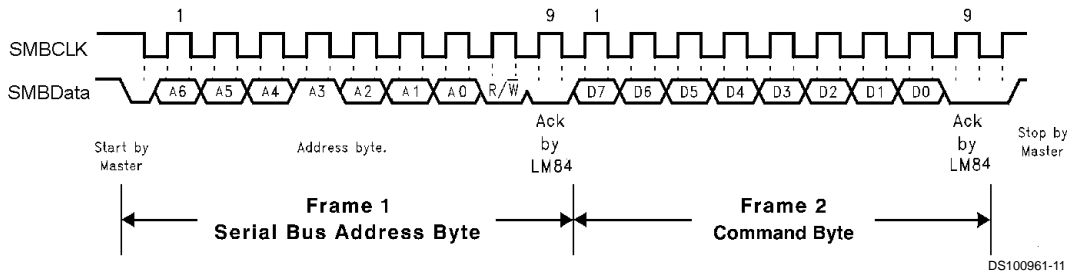

DS100961-11

(b) Serial Bus Write to the internal Command Register

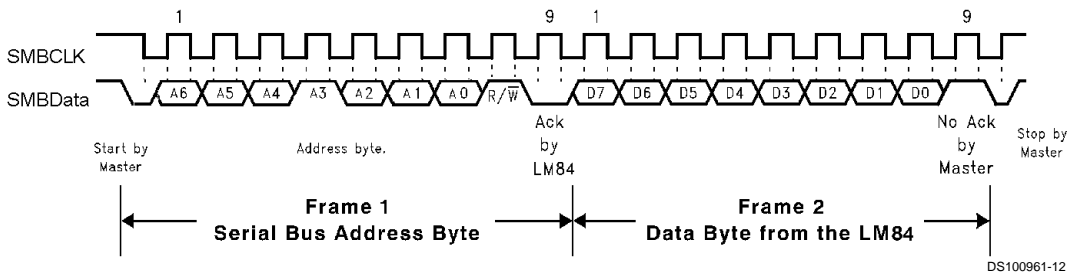

DS100961-12

(c) Serial Bus Read from a Register with the internal Command Register preset to desired value.

FIGURE 4. Serial Bus Timing Diagrams

3.0 Application Hints

The LM84 can be applied easily in the same way as other integrated-circuit temperature sensors, and its remote diode sensing capability allows it to be used in new ways as well. It can be soldered to a printed circuit board, and because the path of best thermal conductivity is between the die and the pins, its temperature will effectively be that of the printed circuit board lands and traces soldered to the LM84's pins. This presumes that the ambient air temperature is almost the same as the surface temperature of the printed circuit board; if the air temperature is much higher or lower than the surface temperature, the actual temperature of the of the LM84 die will be at an intermediate temperature between the surface and air temperatures. Again, the primary thermal conduction path is through the leads, so the circuit board temperature will contribute to the die temperature much more strongly than will the air temperature.

To measure temperature external to the LM84's die, use a remote diode. This diode can be located on the die of a target IC, allowing measurement of the IC's temperature, independent of the LM84's temperature. The LM84 has been optimized to measure the remote diode of a Pentium II processor as shown in *Figure 5*. A discrete diode can also be used to sense the temperature of external objects or ambient air. Remember that a discrete diode's temperature will be affected, and often dominated, by the temperature of its leads.

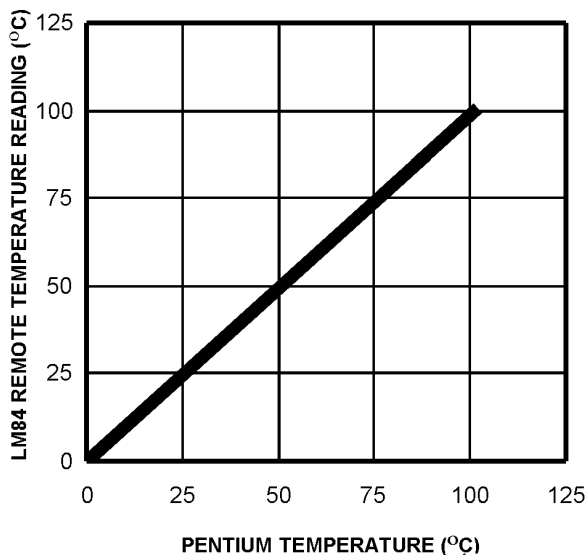

DS100961-16

Pentium Temperature vs LM84 Temperature Reading

Most silicon diodes do not lend themselves well to this application. It is recommended that a 2N3904 transistor base emitter junction be used with the collector tied to the base.

A diode connected 2N3904 approximates the junction available on a Pentium microprocessor for temperature measurement. Therefore, the LM84 can sense the temperature of this diode effectively.

3.1 ACCURACY EFFECTS OF DIODE NON-IDEALITY FACTOR

The technique used in today's remote temperature sensors is to measure the change in V_{BE} at two different operating points of a diode. For a bias current ratio of N:1, this difference is given as:

$$\Delta V_{BE} = \eta \frac{kT}{q} \ln(N)$$

where:

- η is the non-ideality factor of the process the diode is manufactured on,
- q is the electron charge,
- k is the Boltzmann's constant,
- N is the current ratio,
- T is the absolute temperature in °K.

The temperature sensor then measures ΔV_{BE} and converts to digital data. In this equation, k and q are well defined universal constants, and N is a parameter controlled by the temperature sensor. The only other parameter is η , which depends on the diode that is used for measurement. Since ΔV_{BE} is proportional to both η and T , the variations in η cannot be distinguished from variations in temperature. Since the non-ideality factor is not controlled by the temperature sensor, it will directly add to the inaccuracy of the sensor. For the Pentium II Intel specifies a $\pm 1\%$ variation in η from part to part. As an example, assume a temperature sensor has an accuracy specification of $\pm 3^\circ\text{C}$ at room temperature of 25°C and the process used to manufacture the diode has a non-ideality variation of $\pm 1\%$. The resulting accuracy of the temperature sensor at room temperature will be:

$$T_{ACC} = \pm 3^\circ\text{C} + (\pm 1\% \text{ of } 298^\circ\text{K}) = \pm 6^\circ\text{C}.$$

The additional inaccuracy in the temperature measurement caused by η , can be eliminated if each temperature sensor is calibrated with the remote diode that it will be paired with.

3.2 PCB LAYOUT for MINIMIZING NOISE

In a noisy environment, such as a processor mother board, layout considerations are very critical. Noise induced on traces running between the remote temperature diode sensor and the LM84 can cause temperature conversion errors. The following guidelines should be followed:

1. Place a $0.1 \mu\text{F}$ power supply bypass capacitor as close as possible to the V_{CC} pin and the recommended 2.2 nF capacitor as close as possible to the D+ and D- pins. Make sure the traces to the 2.2 nF capacitor are matched.
2. Ideally, the LM84 should be placed within 10 cm of the Processor diode pins with the traces being as straight, short and identical as possible.
3. Diode traces should be surrounded by a GND guard ring to either side, above and below if possible. This GND guard should not be between the D+ and D- lines. In the event that noise does couple to the diode lines it would be ideal if it is coupled common mode. That is equally to the D+ and D- lines. (See *Figure 6*)
4. Avoid routing diode traces in close proximity to power supply switching or filtering inductors.
5. Avoid running diode traces close to or parallel to high speed digital and bus lines. Diode traces should be kept at least 2 cm. apart from the high speed digital traces.
6. If it is necessary to cross high speed digital traces, the diode traces and the high speed digital traces should cross at a 90 degree angle.

3.0 Application Hints (Continued)

- The ideal place to connect the LM84's GND pin is as close as possible to the Processors GND associated

with the sense diode. For the Pentium II this would be pin A14.

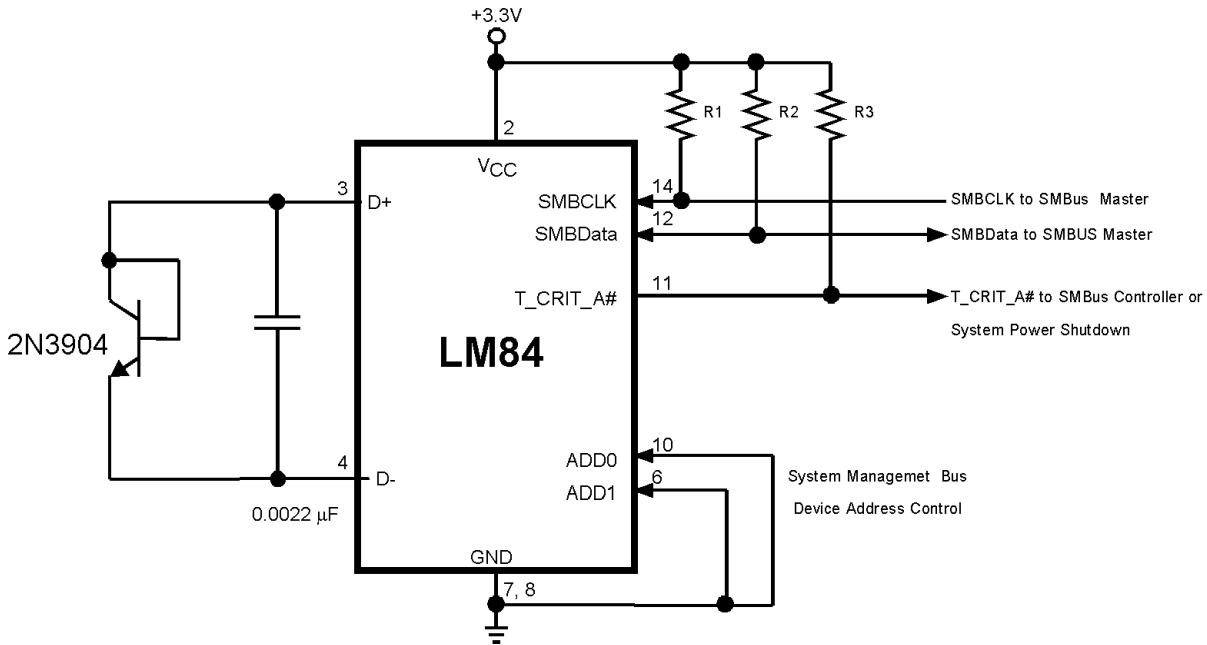

FIGURE 6. Recommended Diode Trace Layout

Noise on the digital lines, overshoot greater than V_{CC} and undershoot less than GND, may prevent successful SMBus communication with the LM84. SMBus no acknowledge is the most common symptom, causing unnecessary traffic on the bus. Although, the SMBus maximum frequency of com-

munication is rather low (400 kHz max) care still needs to be taken to ensure proper termination within a system with multiple parts on the bus and long printed circuit board traces.

4.0 Typical Applications



DS100961-17

Using a Diode Connected 2N3904 as a Remote Temperature Sensing Element

Physical Dimensions inches (millimeters) unless otherwise noted

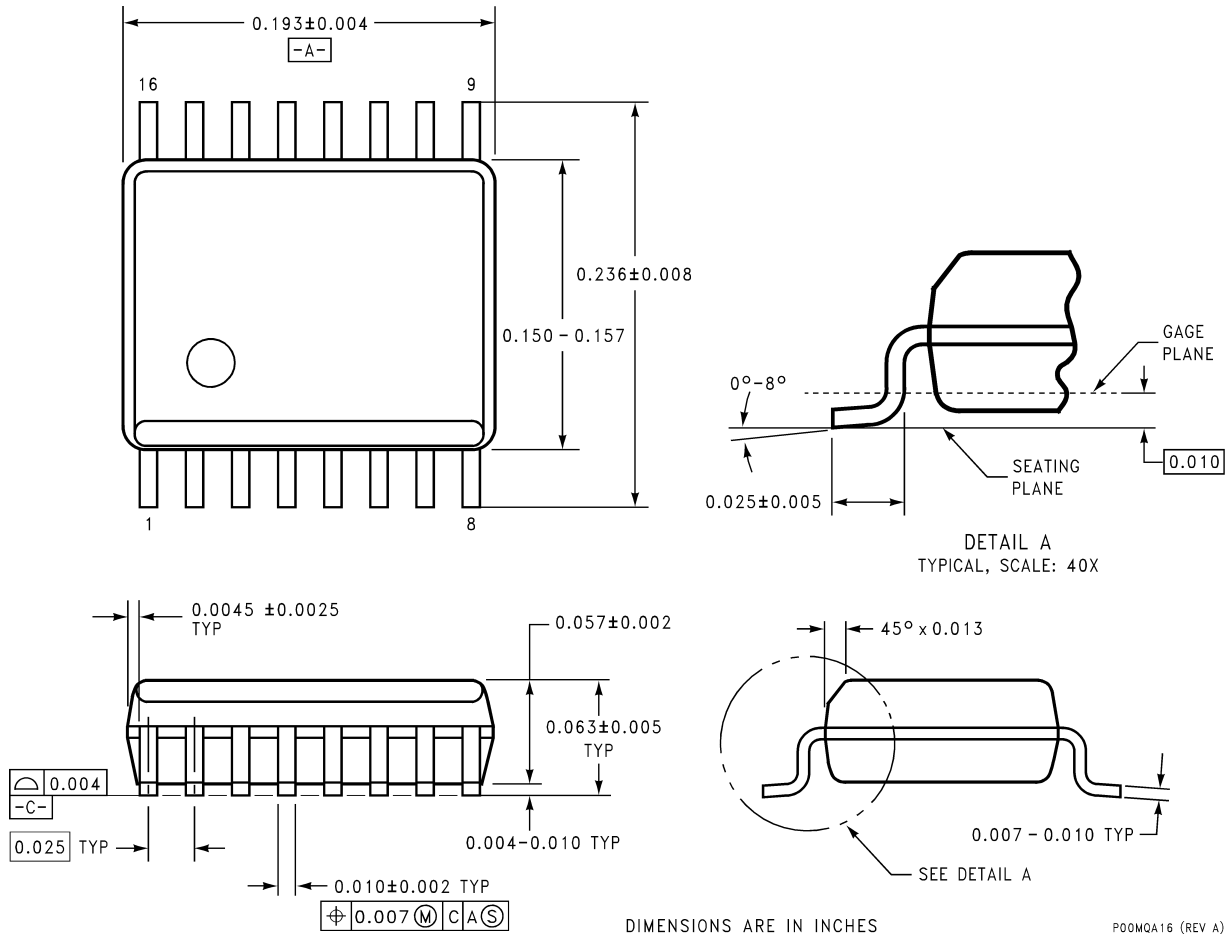

16-Lead QSOP Package
Order Number LM84BIMQA, LM84BIMQAX, LM84CIMQA or LM84CIMQAX
NS Package Number MQA16

LIFE SUPPORT POLICY

NATIONAL'S PRODUCTS ARE NOT AUTHORIZED FOR USE AS CRITICAL COMPONENTS IN LIFE SUPPORT DEVICES OR SYSTEMS WITHOUT THE EXPRESS WRITTEN APPROVAL OF THE PRESIDENT AND GENERAL COUNSEL OF NATIONAL SEMICONDUCTOR CORPORATION. As used herein:

1. Life support devices or systems are devices or systems which, (a) are intended for surgical implant into the body, or (b) support or sustain life, and whose failure to perform when properly used in accordance with instructions for use provided in the labeling, can be reasonably expected to result in a significant injury to the user.
2. A critical component is any component of a life support device or system whose failure to perform can be reasonably expected to cause the failure of the life support device or system, or to affect its safety or effectiveness.

National Semiconductor Corporation
 Americas
 Tel: 1-800-272-9959
 Fax: 1-800-737-7018
 Email: support@nsc.com
 www.national.com

National Semiconductor Europe
 Fax: +49 (0) 180-530 85 86
 Email: europe.support@nsc.com
 Deutsch Tel: +49 (0) 69 9508 6208
 English Tel: +44 (0) 870 24 0 2171
 Français Tel: +33 (0) 1 41 91 8790

National Semiconductor Asia Pacific Customer Response Group
 Tel: 65-2544466
 Fax: 65-2504466
 Email: ap.support@nsc.com

National Semiconductor Japan Ltd.
 Tel: 81-3-5639-7560
 Fax: 81-3-5639-7507

IMPORTANT NOTICE

Texas Instruments Incorporated and its subsidiaries (TI) reserve the right to make corrections, modifications, enhancements, improvements, and other changes to its products and services at any time and to discontinue any product or service without notice. Customers should obtain the latest relevant information before placing orders and should verify that such information is current and complete. All products are sold subject to TI's terms and conditions of sale supplied at the time of order acknowledgment.

TI warrants performance of its hardware products to the specifications applicable at the time of sale in accordance with TI's standard warranty. Testing and other quality control techniques are used to the extent TI deems necessary to support this warranty. Except where mandated by government requirements, testing of all parameters of each product is not necessarily performed.

TI assumes no liability for applications assistance or customer product design. Customers are responsible for their products and applications using TI components. To minimize the risks associated with customer products and applications, customers should provide adequate design and operating safeguards.

TI does not warrant or represent that any license, either express or implied, is granted under any TI patent right, copyright, mask work right, or other TI intellectual property right relating to any combination, machine, or process in which TI products or services are used. Information published by TI regarding third-party products or services does not constitute a license from TI to use such products or services or a warranty or endorsement thereof. Use of such information may require a license from a third party under the patents or other intellectual property of the third party, or a license from TI under the patents or other intellectual property of TI.

Reproduction of TI information in TI data books or data sheets is permissible only if reproduction is without alteration and is accompanied by all associated warranties, conditions, limitations, and notices. Reproduction of this information with alteration is an unfair and deceptive business practice. TI is not responsible or liable for such altered documentation. Information of third parties may be subject to additional restrictions.

Resale of TI products or services with statements different from or beyond the parameters stated by TI for that product or service voids all express and any implied warranties for the associated TI product or service and is an unfair and deceptive business practice. TI is not responsible or liable for any such statements.

TI products are not authorized for use in safety-critical applications (such as life support) where a failure of the TI product would reasonably be expected to cause severe personal injury or death, unless officers of the parties have executed an agreement specifically governing such use. Buyers represent that they have all necessary expertise in the safety and regulatory ramifications of their applications, and acknowledge and agree that they are solely responsible for all legal, regulatory and safety-related requirements concerning their products and any use of TI products in such safety-critical applications, notwithstanding any applications-related information or support that may be provided by TI. Further, Buyers must fully indemnify TI and its representatives against any damages arising out of the use of TI products in such safety-critical applications.

TI products are neither designed nor intended for use in military/aerospace applications or environments unless the TI products are specifically designated by TI as military-grade or "enhanced plastic." Only products designated by TI as military-grade meet military specifications. Buyers acknowledge and agree that any such use of TI products which TI has not designated as military-grade is solely at the Buyer's risk, and that they are solely responsible for compliance with all legal and regulatory requirements in connection with such use.

TI products are neither designed nor intended for use in automotive applications or environments unless the specific TI products are designated by TI as compliant with ISO/TS 16949 requirements. Buyers acknowledge and agree that, if they use any non-designated products in automotive applications, TI will not be responsible for any failure to meet such requirements.

Following are URLs where you can obtain information on other Texas Instruments products and application solutions:

Products

Audio	www.ti.com/audio
Amplifiers	amplifier.ti.com
Data Converters	dataconverter.ti.com
DLP® Products	www.dlp.com
DSP	dsp.ti.com
Clocks and Timers	www.ti.com/clocks
Interface	interface.ti.com
Logic	logic.ti.com
Power Mgmt	power.ti.com
Microcontrollers	microcontroller.ti.com
RFID	www.ti-rfid.com
OMAP Mobile Processors	www.ti.com/omap
Wireless Connectivity	www.ti.com/wirelessconnectivity

Applications

Communications and Telecom	www.ti.com/communications
Computers and Peripherals	www.ti.com/computers
Consumer Electronics	www.ti.com/consumer-apps
Energy and Lighting	www.ti.com/energy
Industrial	www.ti.com/industrial
Medical	www.ti.com/medical
Security	www.ti.com/security
Space, Avionics and Defense	www.ti.com/space-avionics-defense
Transportation and Automotive	www.ti.com/automotive
Video and Imaging	www.ti.com/video

TI E2E Community Home Page

e2e.ti.com

Mailing Address: Texas Instruments, Post Office Box 655303, Dallas, Texas 75265
Copyright © 2011, Texas Instruments Incorporated