

ISSUE 1; February 2016

Description

- High Holdover Capability PTP, 1588 Clock Module.
Designed to provide easy-to-use holdover capability for GPS receivers. Ideal protection against deliberate or accidental GPS jamming and weather-related outages
Applications include Base Station, Clock Source, Clock Server and IP Backhaul
Supports IEEE 1588V2, can be 1588 master or slave
Holdover stability up to 1.5µs over 24 hours, achieved using an adaptive algorithm.
Internal parameters of the algorithm, including maintenance alarms and messages are available to the user via serial interface.
- Working States (Reference Drawing):
Run1: Fast track. Adjust the OCXO 10MHz output frequency quickly to track the 1PPS to 10MHz with 1PPS reference.
Run2: Slow track. Adjust the OCXO 10MHz output frequency slowly when phase error is in the defined range.
Holdover: No 1PPS input present; an algorithm enables adaptive modelling of the frequency stability of an OCXO with reference to the GPS timing signal.
Free Run: Clock module powered up with no 1PPS input.
- Note1: The IQCM-300 should be left powered and running for 7 days minimum before operation to allow for the OCXO's internal drift to stabilise.
Note2: The adaptive module algorithm can be built after two days operation with good GPS signal, however this data will be lost at power down.
- System Mode
SYS_MODE0 SYS_MODE1 Operation

pin17	pin21	
0	0	Combined PTP & Phy Layer Timing
0	1	SGMII/Ethernet self test port 0
1	0	SGMII/Ethernet self test port 1
1	1	Restore factory default settings



Outline (mm)

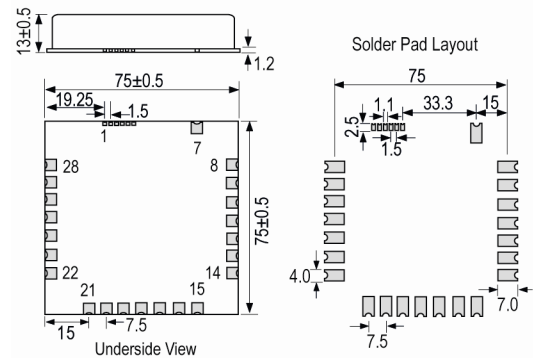

Working States Diagram

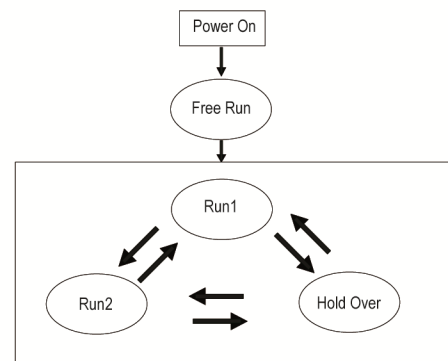

Frequency Parameters

- Frequency 10.0MHz
- 10MHz RF Output Details, Pin 18:
HCMOS Compatible, 15pF load
VoH: 2.7V min
VoL: 0.4V max
Rise and Fall time: 8ns max
Duty Cycle: 45/55% max
Accuracy (24-hour averaging when locked to 1PPS): ±1E-12
Short Term Stability (tested after power for 1hr ref to 25°C, 1s, using PN9000 test equipment): 5E-12 max
Ageing (Vs and temperature constant, reference to T=25°C, V = 5.0V and after 30 days operation): ±0.2ppb per day, ±10ppb per year
- 24Hrs Holdover capability vs temperature change
±1.5µs max
ΔT<±5°C during holdover period
Reference 7 days powered on, 3 days GNSS lock
Temperature varied <1°C/min within operating temperature range

Sales Office Contact Details:

UK: +44 (0)1460 270200
Germany: 0800 1808 443

France: 0800 901 383
USA: +1.760.318.2824

Email: info@iqdfrequencyproducts.com
Web: www.iqdfrequencyproducts.com

Electrical Parameters

- Supply Voltage 5.0V \pm 5%
- 1PPS Reference Input, Pin 10 (50 Ω test condition):
Supplied from your GNSS system, or alternative 1PPS source.
Waveform: HCMOS
ViH: 2.7V min
ViL: 0.4V max
Pulse Width: 10us min
- Force Hold Input Pin 11:
Used to force the unit into holdover mode regardless of GNSS lock status.
Test condition <5mA load
Lock: 2.7V min
Force Hold: 0.4V max
- Power Supply Details, Pin 9:
Supply Voltage: 5.0V \pm 5%
Current Consumption: 2.0A during warm up, 1A steady state @25°C
AC Ripple: 50mV pk-pk max, 10Hz to 1MHz
- PTP Interface pin 2, 3, 4, 5:
Serial Gigabyte Media Independent Interface SGMII supply voltage levels:
Rx analogue DC, 1.2V: -0.5V min 1.4V max
Tx analogue DC, 1.2V: -0.5V min 1.4V max
Rx analogue DC, 3.3V: -0.5V min 3.7V max
TX analogue DC, 3.3V: -0.5V min 3.7V max
Digital DC, 1.2V: -0.5V min 1.4V max
RX analogue DC, 1.2V: -0.5V min 1.4V max
TX analogue DC, 1.2V: -0.5V min 1.4V max
RX analogue DC, 3.3V: -0.5V min 3.7V max
TX analogue DC, 3.3V: -0.5V min 3.7V max

Operating Temperature Ranges

- 20 to 75°C

Output Details

- Output Compatability HCMOS
- 1PPS Reference Output, Pin 12 (15pF test condition):
Waveform: HCMOS
VoH: 2.7V min
VoL: 0.4V max
Pulse Width: 100ms min
- Lock Status Indicator, Pin 16:
Module Locked: 2.7V min
Module Holdover: 0.4V max
Module Locked means Working State is = Run2
- Serial Interface (pin14 and pin15)
VoL and ViL: 0.4V max
VoH and ViH: 2.7V min
Baud rate: 9600
Bits: 8
Paraty: N
Stop Bit: 1

Noise Parameters

- Phase Noise on 10MHz RF output signal (dBm/Hz)

Offset	Typical	Max
10Hz	-118	-113
100Hz	-138	-133
1kHz	-148	-143
10kHz	-150	-145
100kHz	-150	-150
1MHz	-150	-150

Sales Office Contact Details:

UK: +44 (0)1460 270200
Germany: 0800 1808 443

France: 0800 901 383
USA: +1.760.318.2824

Email: info@iqdfrequencyproducts.com
Web: www.iqdfrequencyproducts.com

Environmental Parameters

- Operating Temperature Range: -20 to 75°C
- Storage Conditions:
Temperature: -55 to 105°C
Humidity: 30 to 80%
- Shock: IEC68-2-27 Test Ea, severity 50A, 50G 11ms half sinewave, 3 times in three mutually perpendicular axes
- Vibration: IEC 68-2-06 Test Fc, 10G, 0.75mm acceleration, 10Hz to 500Hz, 3 times in three mutually perpendicular axes

Manufacturing Details

- ESD Level:
ANSI/ESDA/JEDEC JS-001-2010; HBM Class 2; 2kV to 4kV
ANSI/ESDA/JEDEC JS-001-2010; Machine Model Class B
200V to 400V

Ordering Information

- Alternative options may be available regarding operating temperature range, output type and holdover stability time and temperature change. Please contact our sales department for details.

Compliance

- RoHS Status (2011/65/EU) Compliant
- REACh Status Compliant
- MSL Rating (JDEC-STD-033): Not Applicable

Packaging Details

- Pack Style: Bulk Loose in bulk pack
Pack Size: 1

Typical Application

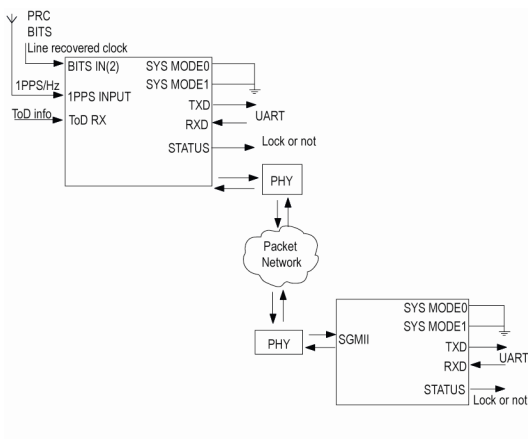

Sales Office Contact Details:

UK: +44 (0)1460 270200
Germany: 0800 1808 443

France: 0800 901 383
USA: +1.760.318.2824

Email: info@iqdfrequencyproducts.com
Web: www.iqdfrequencyproducts.com

Pin Configuration

	Pin Number	Name	Description		
	1,6,8	GND	Ground		
	2	SGMII_RXN	PTP port, SGMII interface		
	3	SGMII_RXP	PTP port, SGMII interface		
	4	SGMII_TXN	PTP port, SGMII interface		
	5	SGMII_TXP	PTP port, SGMII interface		
	7	BIT_IN	Building Integrated Timing Supply input reference clock		
	9	VS	Supply Voltage 4.75V to 5.25V		
	10	1PPS_INPUT	1PPS input signal, from GNSS or other reference source		
	11	FORCE_HOLD	When low the unit operates in holdover mode		
	12	1PPS_OUTPUT	1PPS output signal		
	13	CK_OUTPUT	Frequency Aligned output: 1Hz and programmable frequency from 1kHz to 180MHz		
	14	TXD	Serial Interface for access to date word 9600-N-8-1		
	15	RXD	Serial Interface for access to date word 9600-N-8-1		
	16	STATUS	Lock Status: 1 = locked, 0 = Free Run or Holdover		
	17	SYS_MODE0	See Notes		
	18	RF OUTPUT	10MHz output from OCXO		
	19	RESET	Reset the clock module		
	20	TOPSYNC_FAULT	fault alarm		
	21	SYS_MODE1	See Notes		
	22	SPI_CLK	Serial Peripheral Interface slave port for comm's with microprocessor control	Serial Clock	
	23	SPI_SDI	Serial Peripheral Interface slave port for comm's with microprocessor control	Slave Input	
	24	SPI_SDO	Serial Peripheral Interface slave port for comm's with microprocessor control	Slave Output	
	25	SPI_CS	Serial Peripheral Interface slave port for comm's with microprocessor control	Slave Select	
	26	SPI_INT	Serial Peripheral Interface slave port for comm's with microprocessor control	Interrupt	
	27	TOD_RX	Time of Day input NMEA0183 or UBX Protocol. UART has intergrated baud rate generator, 1 sopt bit, no parity, max baud 19200		
	28	TOD_TX	Time of Day input NMEA0183 or UBX Protocol. UART has intergrated baud rate generator, 1 sopt bit, no parity, max baud 19200		

Sales Office Contact Details:

UK: +44 (0)1460 270200
Germany: 0800 1808 443

France: 0800 901 383
USA: +1.760.318.2824

Email: info@iqdfrequencyproducts.com
Web: www.iqdfrequencyproducts.com