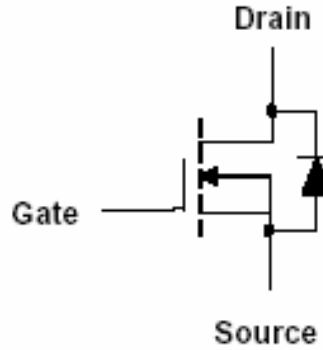

TO-252 (D-Pack)
Internal Schematic Diagram

N-Channel MOSFET
Features

Advanced trench process technology
 High Density Cell Design For Ultra Low On-Resistance
 Specially Designed for DC/DC Converters and Motor Drivers
 Fully Characterized Avalanche Voltage and Current

 $V_{DS} = 25V$
 $R_{DS(ON)}, V_{GS}@10V, I_{DS}@30A = 8.5m\Omega$
 $R_{DS(ON)}, V_{GS}@4.5V, I_{DS}@30A = 13m\Omega$
Maximum Ratings and Thermal Characteristics ($T_A = 25^\circ C$ unless otherwise noted)

Parameter	Symbol	Limit	Unit	
Drain-Source Voltage	V_{DS}	25	V	
Gate-Source Voltage	V_{GS}	± 20		
Continuous Drain Current	I_D	35	A	
Pulsed Drain Current ¹⁾	I_{DM}	350		
Maximum Power Dissipation		$T_A = 25^\circ C$	57	W
		$T_A = 100^\circ C$	23	
Operating Junction and Storage Temperature Range	T_J, T_{stg}	-55 to 150	$^\circ C$	
Avalanche Energy with Single Pulse $I_D=35A, V_{DD}=25V, L=0.5mH$	E_{AS}	300	mJ	
Junction-to-Case Thermal Resistance	$R_{\theta JC}$	2.2	$^\circ C/W$	
Junction-to-Ambient Thermal Resistance (PCB mounted) ²⁾	$R_{\theta JA}$	50		

Note: 1. Maximum DC current limited by the package

 2. 1-in² 2oz Cu PCB board



FMD35N02 25V N-Channel Enhancement-Mode

ELECTRICAL CHARACTERISTICS

Parameter	Symbol	Test Condition	Min	Typ	Max	Unit
Static						
Drain-Source Breakdown Voltage	BV_{DSS}	$V_{GS} = 0V, I_D = 250\mu A$	25	-	-	V
Drain-Source On-State Resistance	$R_{DS(on)}$	$V_{GS} = 4.5V, I_D = 30A$		10.0	13	m Ω
Drain-Source On-State Resistance	$R_{DS(on)}$	$V_{GS} = 10V, I_D = 30A$		6.5	8.5	
Gate Threshold Voltage	$V_{GS(th)}$	$V_{DS} = V_{GS}, I_D = 250\mu A$	1	1.6	3	V
Zero Gate Voltage Drain Current	I_{DSS}	$V_{DS} = 24V, V_{GS} = 0V$			1	μA
Gate Body Leakage	I_{GSS}	$V_{GS} = \pm 20V, V_{DS} = 0V$			± 100	nA
Gate Resistance	R_g					
Forward Transconductance	g_{fs}	$V_{DS} = 10V, I_D = 35A$				S
Dynamic						
Total Gate Charge	Q_g	$V_{DS} = 15V, I_D = 35A$ $V_{GS} = 10V$		24		nC
Gate-Source Charge	Q_{gs}			5.4		
Gate-Drain Charge	Q_{gd}			4.0		
Turn-On Delay Time	$t_{d(on)}$	$V_{DD} = 15V, R_L = 15\Omega$ $I_D = 1A, V_{GEN} = 10V$ $R_G = 24\Omega$		15.0		ns
Turn-On Rise Time	t_r			3.2		
Turn-Off Delay Time	$t_{d(off)}$			36		
Turn-Off Fall Time	t_f			4.8		
Input Capacitance	C_{iss}	$V_{DS} = 15V, V_{GS} = 0V$ $f = 1.0\text{ MHz}$		1940		pF
Output Capacitance	C_{oss}			312		
Reverse Transfer Capacitance	C_{rss}			122		
Source-Drain Diode						
Max. Diode Forward Current	I_S				50	A
Diode Forward Voltage	V_{SD}	$I_S = 20A, V_{GS} = 0V$		0.87	1.5	V

Note: Pulse test: pulse width $\leq 300\mu s$, duty cycle $\leq 2\%$

