

The **ACTR8002/868.35/DCC6C** is a true one-port, surface-acoustic-wave (**SAW**) resonator in a surface-mount ceramic **DCC6C** case. It provides reliable, fundamental-mode, quartz frequency stabilization i.e. in transmitters or local oscillators operating at **868.350 MHz**.

### 1.Package Dimension (DCC6C)

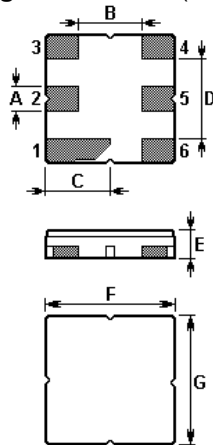

### 2.

Pin	Configuration
2	Input / Output
5	Output / Input
1,3,4,6	Ground

Sign	Data (unit: mm)	Sign	Data (unit: mm)
A	0.6	E	1.1
B	1.5	F	3.0
C	1.5	G	3.0
D	1.8		

### 3.Equivalent LC Model and Test Circuit

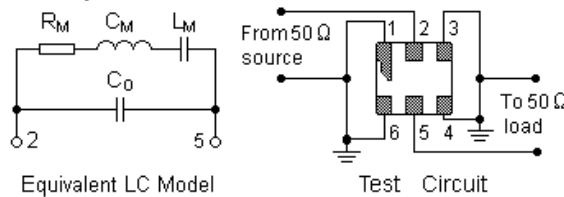

### 4.Typical Application Circuits

#### 1) Low-Power Transmitter Application

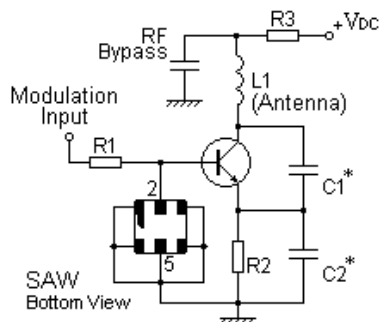

#### 2) Local Oscillator Application

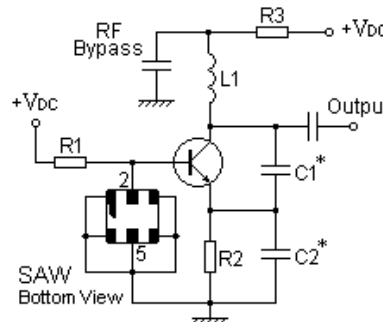

In keeping with our ongoing policy of product evolution and improvement, the above specification is subject to change without notice.

**ISO9001: 2000 Registered**

For quotations or further information please contact us at:

3 The Business Centre, Molly Millars Lane, Wokingham, Berks, RG41 2EY, UK

<http://www.actcrystals.com>

Issue : 1.1 C1

Date : March 2010

## 5. Typical Frequency Response

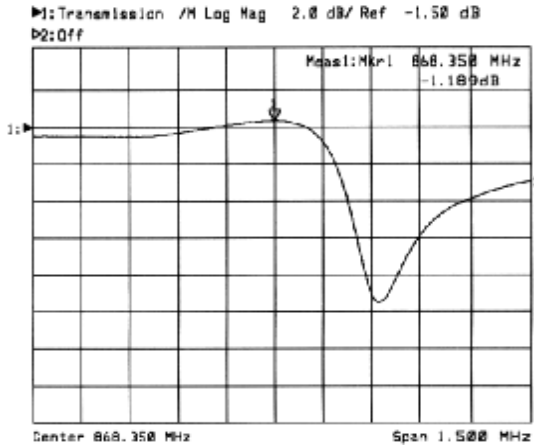

## 6. Temperature Characteristics

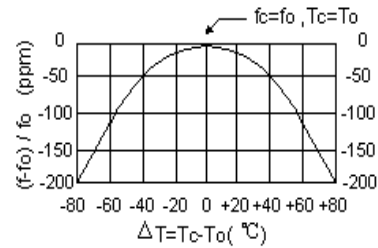

The curve shown above accounts for resonator contribution only and does not include oscillator temperature characteristics.

## 7. Performance

### 7-1. Maximum Ratings

Rating	Value	Units
CW RF Power Dissipation	0	dBm
DC Voltage Between Terminals	±30V	VDC
Case Temperature	-40 to +85	°C
Soldering Temperature	+250	°C

### 7-2. Electronic Characteristics

Characteristic		Sym	Minimum	Typical	Maximum	Unit
Centre Frequency (+25 °C)	Absolute Frequency	$f_c$	868.200		868.500	MHz
	Tolerance from 868.350 MHz	$\Delta f_c$		±150		kHz
Insertion Loss		$I_L$		1.5	2.2	dB
Quality Factor	Unloaded Q	$Q_U$		9,400		
	50 Ω Loaded Q	$Q_L$		1,500		
Temperature Stability	Turnover Temperature	$T_0$	25		55	°C
	Turnover Frequency	$f_0$		$f_c$		kHz
	Frequency Temperature Coefficient	FTC		0.03		ppm/°C <sup>2</sup>
Frequency Aging	Absolute Value during the First Year	fA		≤10		ppm/yr
DC Insulation Resistance Between Any Two Terminals			1.0			MΩ
RF Equivalent RLC Model	Motional Resistance	$R_M$		19	29	Ω
	Motional Inductance	$L_M$		32.7328		μH
	Motional Capacitance	$C_M$		1.0273		fF
	Shunt Static Capacitance	$C_0$	2.1	2.4	2.7	pF

In keeping with our ongoing policy of product evolution and improvement, the above specification is subject to change without notice.

**ISO9001: 2000 Registered**

For quotations or further information please contact us at:

Issue : 1.1 C1

3 The Business Centre, Molly Millars Lane, Wokingham, Berks, RG41 2EY, UK

Date : March 2010

<http://www.actcrystals.com>

**i CAUTION: Electrostatic Sensitive Device. Observe precautions for handling!**

1. The centre frequency,  $f_c$ , is measured at the minimum IL point with the resonator in the 50  $\Omega$  test system.
2. Unless noted otherwise, case temperature  $T_C = +25^\circ\text{C} \pm 2^\circ\text{C}$ .
3. Frequency aging is the change in  $f_c$  with time and is specified at  $+65^\circ\text{C}$  or less. Aging may exceed the specification for prolonged temperatures above  $+65^\circ\text{C}$ . Typically, aging is greatest the first year after manufacture, decreasing in subsequent years.
4. Turnover temperature,  $T_0$ , is the temperature of maximum (or turnover) frequency,  $f_0$ . The nominal frequency at any case temperature,  $T_C$ , may be calculated from:  $f = f_0 [1 - \text{FTC} (T_0 - T_C)^2]$ .
5. This equivalent RLC model approximates resonator performance near the resonant frequency and is provided for reference only. The capacitance  $C_0$  is the measured static (non-motional) capacitance between the two terminals. The measurement includes case parasitic capacitance.
6. Derived mathematically from one or more of the following directly measured parameters:  $f_c$ , IL, 3 dB bandwidth,  $f_c$  versus  $T_C$ , and  $C_0$ .
7. The specifications of this device are based on the test circuit shown above and subject to change or obsolescence without notice.
8. Typically, equipment utilizing this device requires emissions testing and government approval, which is the responsibility of the equipment manufacturer.
9. Our liability is only assumed for the Surface Acoustic Wave (SAW) component(s) per se, not for applications, processes and circuits implemented within components or assemblies.

In keeping with our ongoing policy of product evolution and improvement, the above specification is subject to change without notice.

**ISO9001: 2000 Registered**

**For quotations or further information please contact us at:**

**3 The Business Centre, Molly Millars Lane, Wokingham, Berks, RG41 2EY, UK**

<http://www.actcrystals.com>

Issue : 1.1 C1

Date : March 2010