

isc N-Channel MOSFET Transistor

2SK2224-01

DESCRIPTION

- Drain Current $I_D=3A @ T_C=25^\circ C$
- Drain Source Voltage-
: $V_{DSS}= 900V(\text{Min})$
- Fast Switching Speed

APPLICATIONS

- Switching regulators
- UPS
- DC-DC converters
- General purpose power amplifier

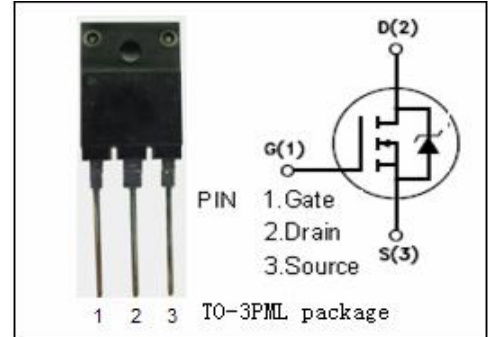

ABSOLUTE MAXIMUM RATINGS($T_a=25^\circ C$)

SYMBOL	PARAMETER	VALUE	UNIT
V_{DSS}	Drain-Source Voltage ($V_{GS}=0$)	900	V
V_{GS}	Gate-Source Voltage	± 30	V
I_D	Drain Current-continuous@ $T_C=25^\circ C$	3	A
$I_{D(\text{puls})}$	Pulse Drain Current	12	A
P_{tot}	Total Dissipation@ $T_C=25^\circ C$	50	W
T_j	Max. Operating Junction Temperature	150	$^\circ C$
T_{stg}	Storage Temperature Range	-55~150	$^\circ C$

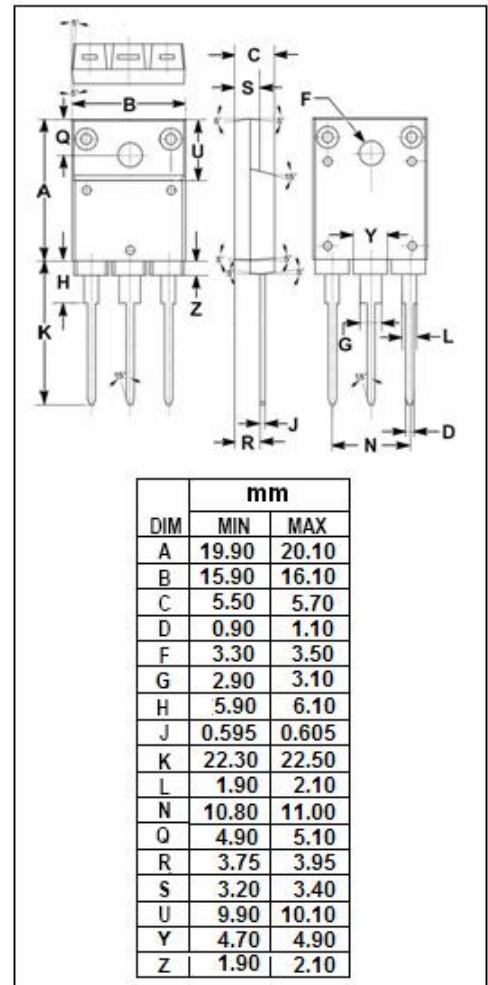

• THERMAL CHARACTERISTICS

SYMBOL	PARAMETER	MAX	UNIT
$R_{th\ j-c}$	Thermal Resistance, Junction to Case	2.5	$^\circ C/W$
$R_{th\ j-a}$	Thermal Resistance, Junction to Ambient	30	$^\circ C/W$

isc N-Channel Mosfet Transistor

2SK2224-01

• ELECTRICAL CHARACTERISTICS ($T_C=25^\circ\text{C}$)

SYMBOL	PARAMETER	CONDITIONS	MIN	TYPE	MAX	UNIT
$V_{(BR)DSS}$	Drain-Source Breakdown Voltage	$V_{GS}=0; I_D=1\text{mA}$	900			V
$V_{GS(th)}$	Gate Threshold Voltage	$V_{DS}=V_{GS}; I_D=1\text{mA}$	2.5	3.0	3.5	V
V_{SD}	Diode Forward On-Voltage	$I_F=2 I_{DR}; V_{GS}=0$		0.98	1.47	V
$R_{DS(on)}$	Drain-Source On-Resistance	$V_{GS}=10\text{V}; I_D=1.5\text{A}$		2.5	4.0	Ω
I_{GSS}	Gate-Body Leakage Current	$V_{GS}= \pm 30\text{V}; V_{DS}=0$			± 100	nA
I_{DSS}	Zero Gate Voltage Drain Current	$V_{DS}=900\text{V}; V_{GS}=0$			500	μA
C_{iss}	Input Capacitance	$V_{DS}=25\text{V};$ $V_{GS}=0\text{V};$ $f_T=1\text{MHz}$		1000	1500	pF
C_{rss}	Reverse Transfer Capacitance			25	40	
C_{oss}	Output Capacitance			90	135	
t_r	Rise Time			10	15	
$t_{d(on)}$	Turn-on Delay Time	$I_D=3\text{A};$		20	30	ns
t_f	Fall Time	$V_{DD}=600\text{V};$ $R_{GS}=10\Omega$		15	25	
$t_{d(off)}$	Turn-off Delay Time			60	90	