



# TAI-SAW TECHNOLOGY CO., LTD.

No. 3, Industrial 2nd Rd., Ping-Chen Industrial District,  
Taoyuan, 324, Taiwan, R.O.C.

TEL: 886-3-4690038 FAX: 886-3-4697532

E-mail: [tstsales@mail.taisaw.com](mailto:tstsales@mail.taisaw.com) Web: [www.taisaw.com](http://www.taisaw.com)

## Product Specifications Approval Sheet

Product Description: SAW Filter 1572.5 MHz SMD 1.4X1.1 mm (BW 30 MHz)

TST Part No.: TA2373A

Customer Part No.: \_\_\_\_\_

Customer signature required
Company: _____
Division: _____
Approved by : _____
Date: _____

Checked by: \_\_\_\_\_ Sam Lin *Sam Lin*

Approved by: \_\_\_\_\_ Andy Yu *Andy Yu*

Date: \_\_\_\_\_ 2018/02/14

1. Customer signed back is required before TST can proceed with sample build and receive orders.
2. Orders received without customer signed back will be regarded as agreement on the specifications.
3. Any specifications changes must be approved upon by both parties and a new revision of specifications shall be released to reflect the changes.



# TAI-SAW TECHNOLOGY CO., LTD.

No. 3, Industrial 2nd Rd., Ping-Chen Industrial District,  
Taoyuan, 324, Taiwan, R.O.C.

TEL: 886-3-4690038 FAX: 886-3-4697532

E-mail: [tstsales@mail.taisaw.com](mailto:tstsales@mail.taisaw.com) Web: [www.taisaw.com](http://www.taisaw.com)

## SAW Filter 1572.5 MHz

MODEL NO.:TA2373A

REV. NO.:1

### A. MAXIMUM RATING:

1. Input Power Level: 10 dBm
2. DC Voltage : 3 V
3. Operating Temperature: -20°C to +70°C
4. Storage Temperature: -40°C to +85°C
5. Moisture Sensitivity Level: Level 3

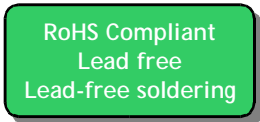

**Electrostatic Sensitive Device (ESD)**

### B. ELECTRICAL CHARACTERISTICS:

Item	Unit	Min.	Typ.	Max.
<b>Center frequency</b>	MHz	-	1572.5	-
<b>Insertion Loss (1557.5 ~ 1587.5 MHz)</b>	dB	-	2.0	3.5
<b>Amplitude Ripple (1557.5 ~ 1587.5 MHz)</b>	dB	-	0.7	2.0
<b>Attenuation (reference level from 0 dB)</b>				
880 ~ 920 MHz	dB	35	38	-
1710 ~ 1850 MHz	dB	20	38	-
1850 ~ 1920 MHz	dB	<b>33</b>	<b>34</b>	-
<b>Temperature Coefficient of Frequency</b>	ppm/°C	-	-36	-

**C.OUTLINE DRAWING:**

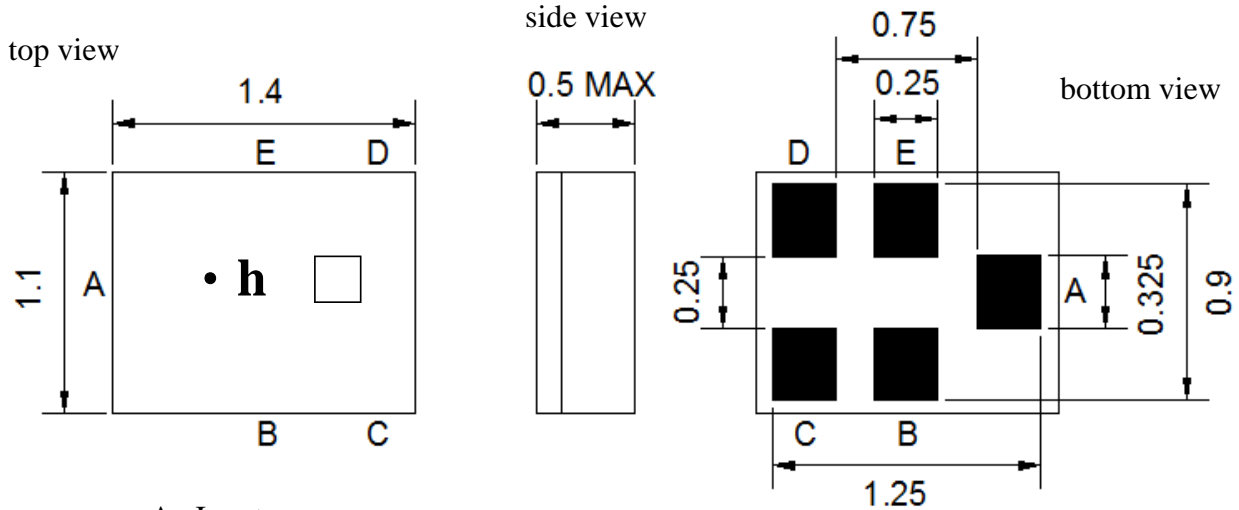

A : Input  
 D : Output  
 B,C,E : Ground  
 Unit : mm

: Year/Month Code (Follow the table)

YEAR/Month	1	2	3	4	5	6	7	8	9	10	11	12
2013	A	B	C	D	E	F	G	H	J	K	L	M
2014	N	P	Q	R	S	T	U	V	W	X	Y	Z
2015	a	b	c	d	e	f	g	h	j	k	l	m
2016	n	p	q	r	s	t	u	v	w	x	y	z
2017	<u>A</u>	<u>B</u>	<u>C</u>	<u>D</u>	<u>E</u>	<u>F</u>	<u>G</u>	<u>H</u>	<u>J</u>	<u>K</u>	<u>L</u>	<u>M</u>
2018	<u>N</u>	<u>P</u>	<u>Q</u>	<u>R</u>	<u>S</u>	<u>T</u>	<u>U</u>	<u>V</u>	<u>W</u>	<u>X</u>	<u>Y</u>	<u>Z</u>
2019	<u>a</u>	<u>b</u>	<u>c</u>	<u>d</u>	<u>e</u>	<u>f</u>	<u>g</u>	<u>h</u>	<u>j</u>	<u>k</u>	<u>l</u>	<u>m</u>
2020	<u>n</u>	<u>p</u>	<u>q</u>	<u>r</u>	<u>s</u>	<u>t</u>	<u>u</u>	<u>v</u>	<u>w</u>	<u>x</u>	<u>y</u>	<u>z</u>

### D. MEASUREMENT CIRCUIT:

By network analyzer simulation with port extension.

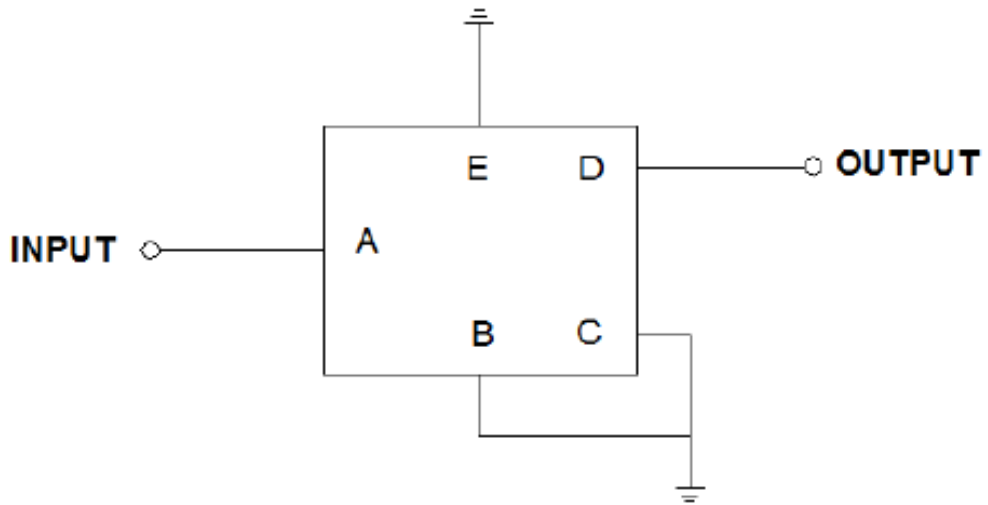

### E. PCB Footprint:

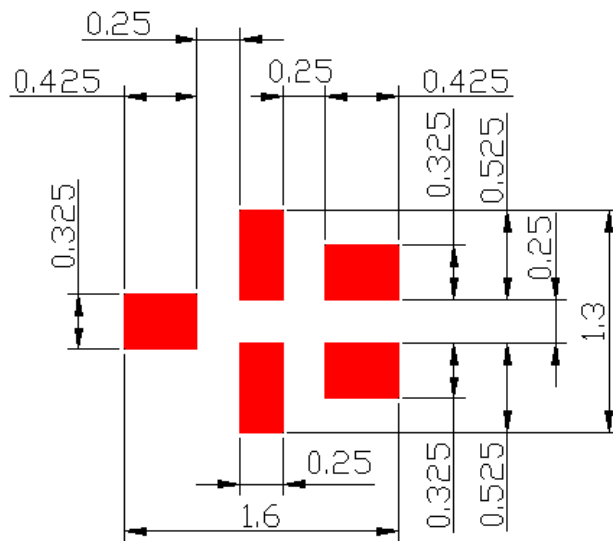

 : Land Pattern  
Unit : mm

**F. Frequency Characteristics:**  
**Span 400 MHz**

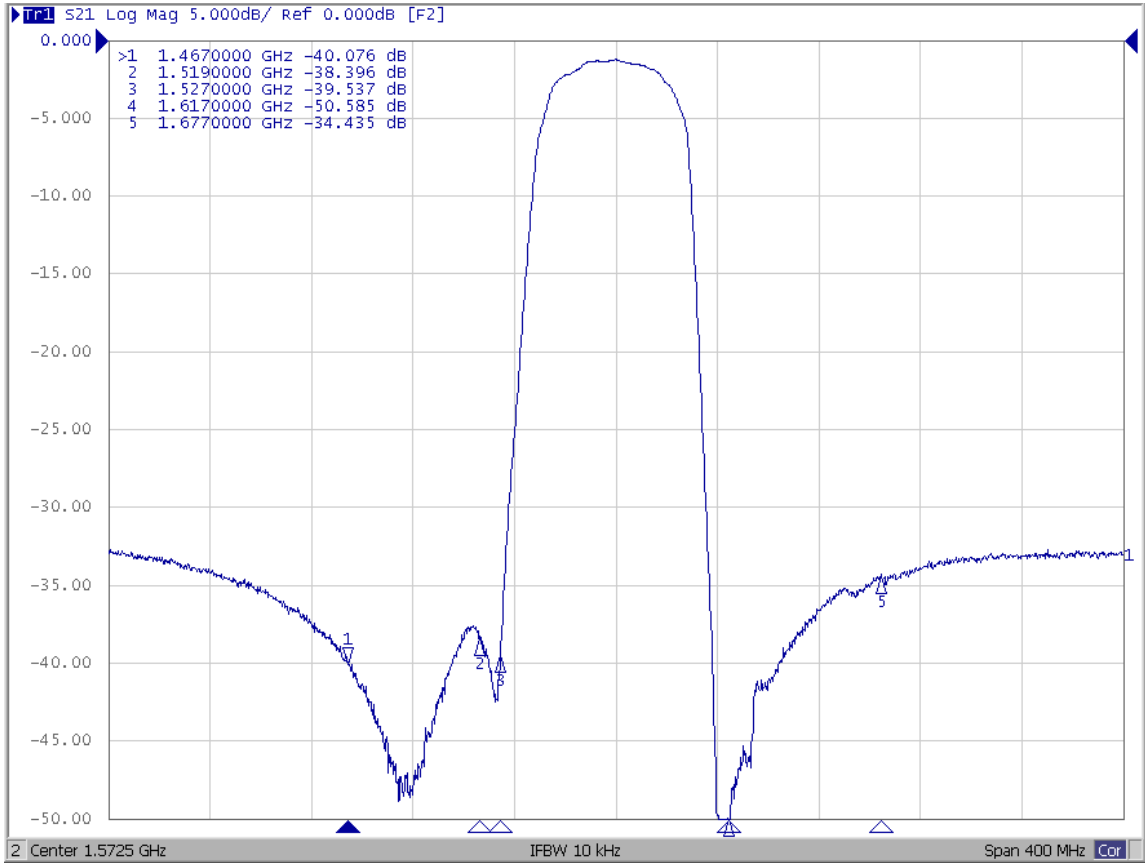

**Span 4000 MHz**

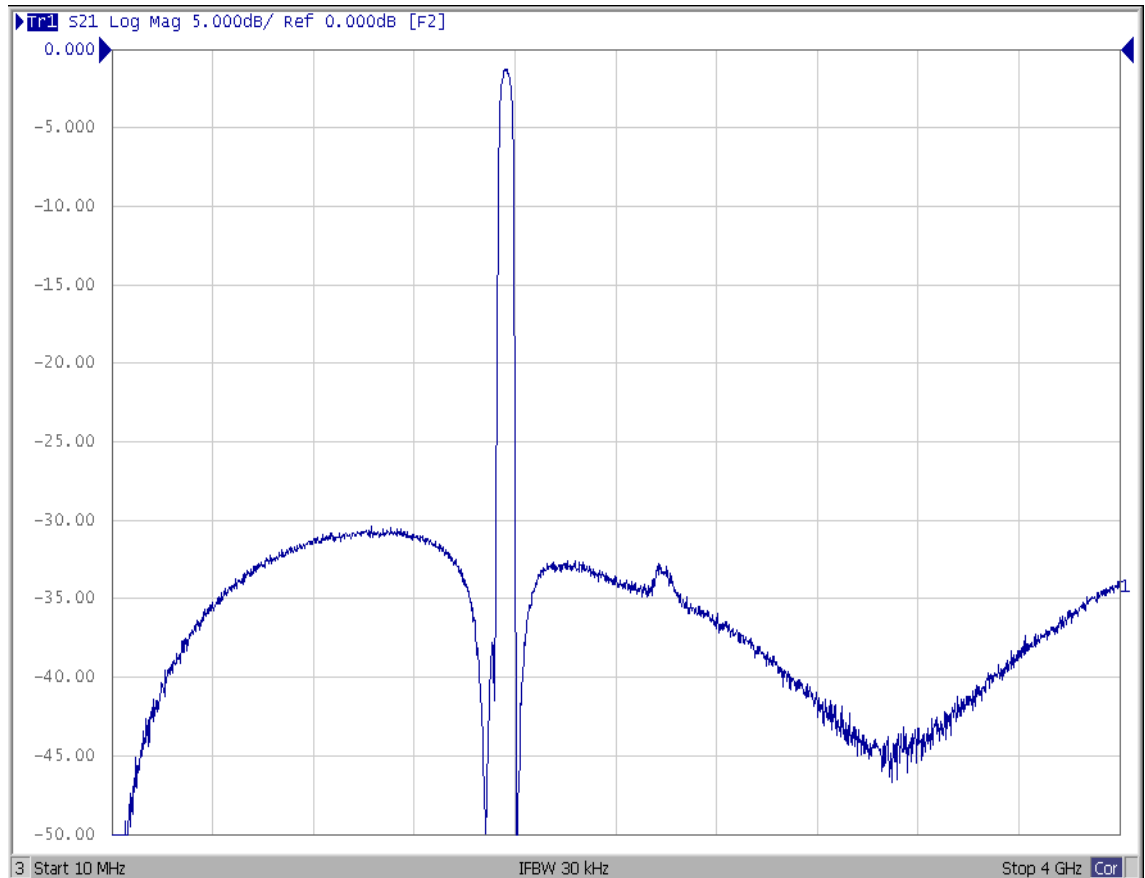

## Span 100 MHz

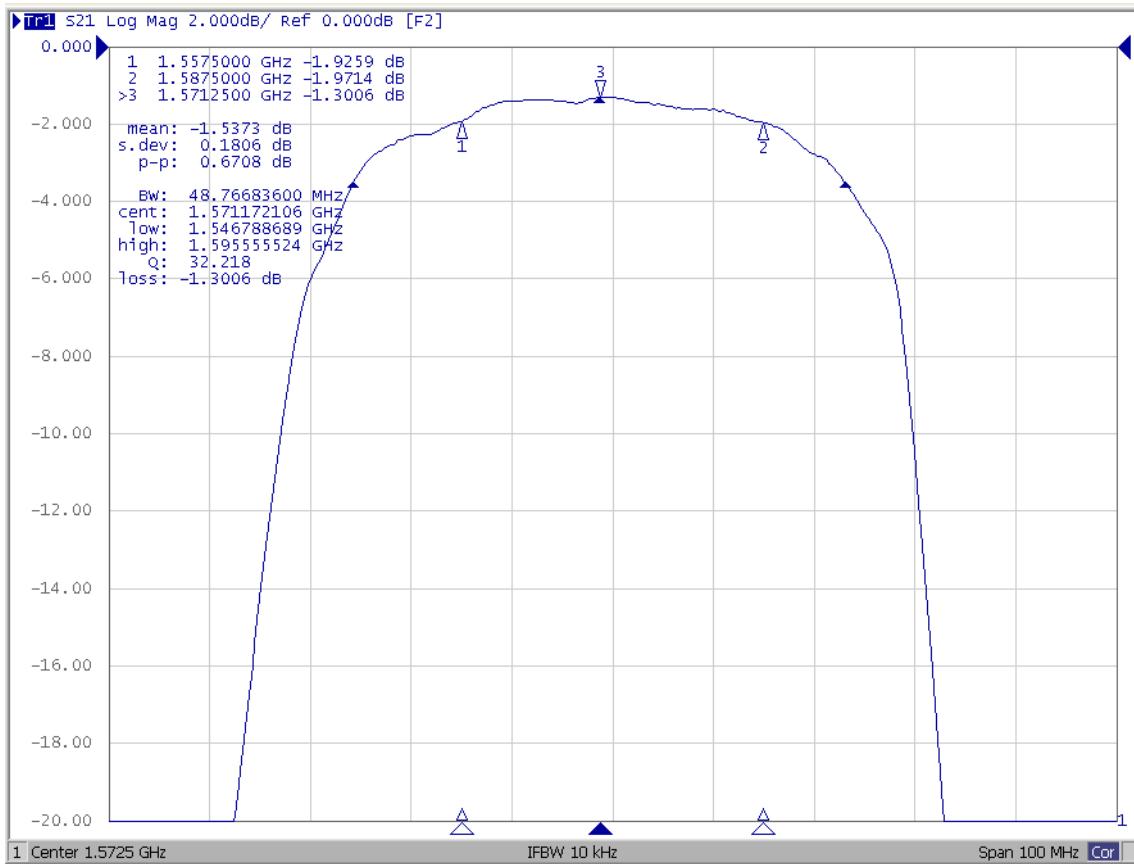

## Reflective Function (Span 100 MHz)

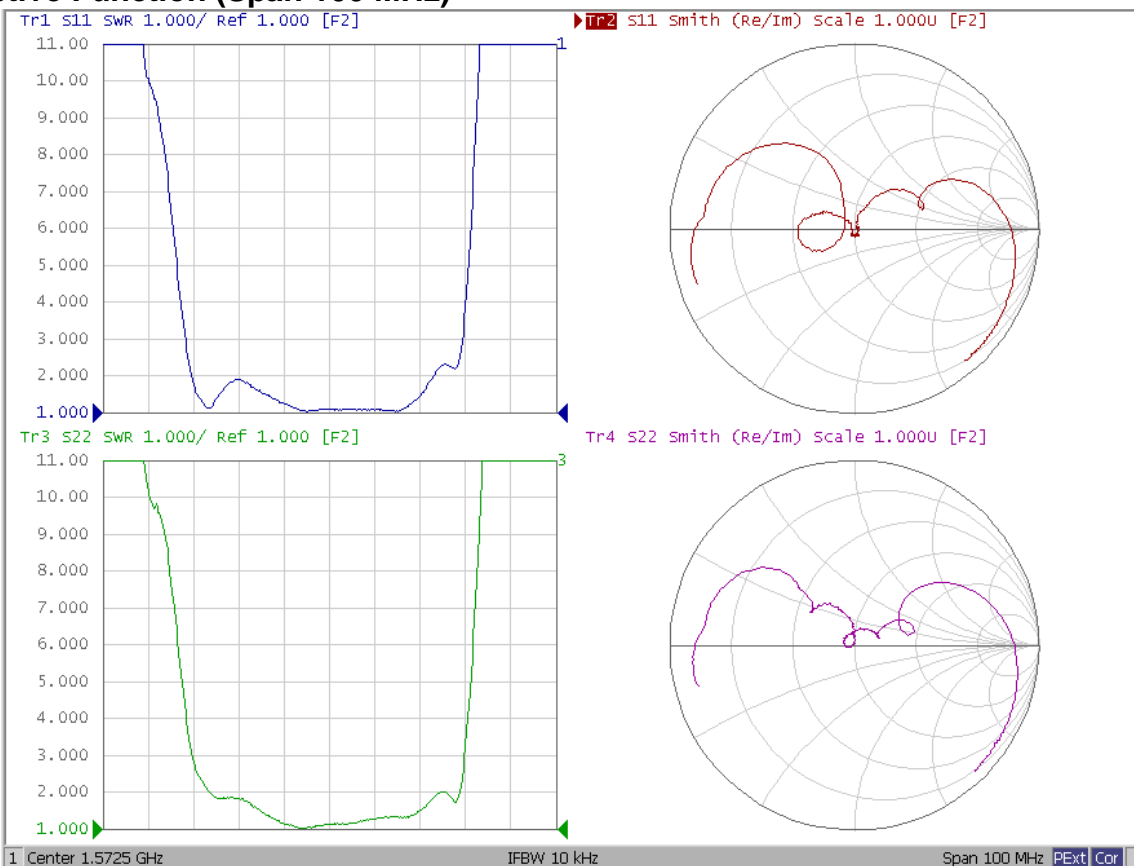

**G. PACKING:**

**1. REEL DIMENSION**

(Please refer to FR-75D10 for packing quantity )

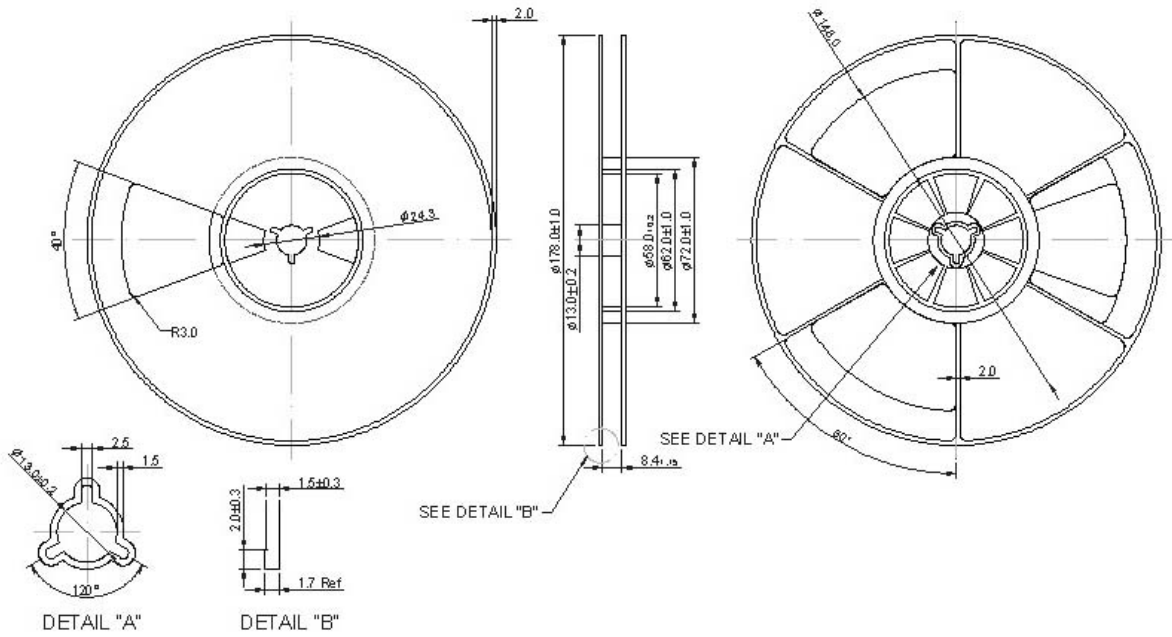

**2. TAPE DIMENSION**

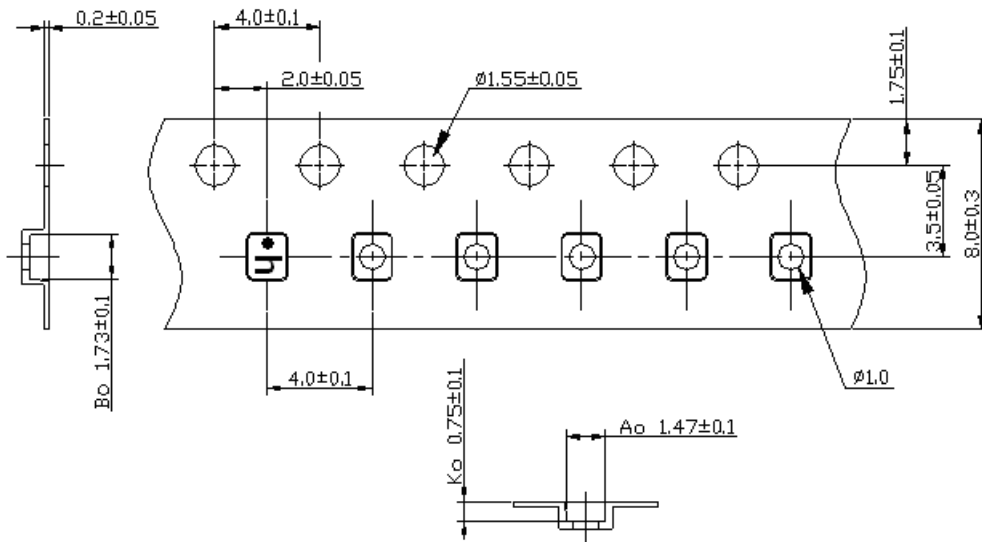

Direction of Feed

## H. RECOMMENDED REFLOW PROFILE :

1. Preheating shall be fixed at 150~180°C for 60~90 seconds.
2. Ascending time to preheating temperature 150°C shall be 30 seconds min.
3. Heating shall be fixed at 220°C for 50~80 seconds and at 260°C +0/-5°C peak (20~40sec).
4. Time: 2 times.

