

3 Channels, High Efficiency, Synchronous Step Down with LDO

Features

- Continuous Loading: 3A (Buck 1), 1A (Buck 2 and 3)
- 1MHz Switching Frequency
- 1.0V ± 2% Voltage Reference Over Temperature
- External Enable/Sequencing and Soft Start Pins
- Adjustable Soft Start
- Power Good Output
- Cycle by Cycle Current Limit, Thermal and Overload protection.
- Built in 500mA LDO
- Thermally Enhanced 4mm × 4mm 28-pin QFN

Applications

- Set Top Boxes
- Blue-ray DVD

General Description

The G2120 device features three synchronous 5.5V input range high efficiency buck converters. The converters are designed to simplify its application while giving the designer the option to optimize their usage according to the target application.

The converters can operate in 5V systems and have integrated power transistors. The output voltage can be set externally using a resistor divider to any value between 1.0V and close to the input supply. Each converter features enable pin that allows a delayed start-up for sequencing purposes, soft start pin that allows adjustable soft-start time by choosing the soft-start capacitor. The current mode control allows a simple RC compensation.

The switching frequency of the converters can operate 1 MHz.

The G2120 features a supervisor circuit that monitors each converter output. The PGOOD pin is asserted once sequencing is done, all PG signals are reported and a selectable end of reset time lapses. The polarity of the PGOOD signal is active high.

The G2120 Buck1 also features a light load pulse skipping mode, PSM mode allows for a reduction on the input power supplied to the system when the host processor is in stand-by (low activity) mode.

Ordering Information

ORDER NUMBER	MARKING	TEMP. RANGE	PACKAGE (Green)
G2120RV1U	2120	-40°C to +85°C	TQFN4X4-28

Note: RV: TQFN4X4-28

1: Bonding Code

U: Tape & Reel

Pin Configuration

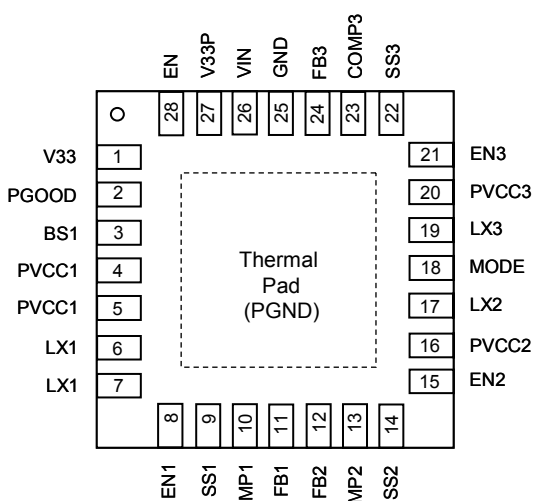

G2120 TQFN4X4-28

Note: Recommend connecting the Thermal Pad to the round for excellent power dissipation.

Typical Application Circuit

