



TAI-SAW TECHNOLOGY CO., LTD.

No. 3, Industrial 2nd Rd., Ping-Chen Industrial District,
Taoyuan, 324, Taiwan, R.O.C.

TEL: 886-3-4690038 FAX: 886-3-4697532

E-mail: tstsales@mail.taisaw.com Web: www.taisaw.com

Product Specifications Approval Sheet

Product Description: SAW Filter 434.7 MHz (BW 1.07MHz) SMD 3X3 mm

TST Part No.: TST Parts No.: TA1820A

Customer Part No.: _____

Customer signature required
Company: _____
Division: _____
Approved by : _____
Date: _____

Checked by: _____ Michael Yang 

Approval by: _____ Bob Chau 

Date: _____ 08/07/2015

1. Customer signed back is required before TST can proceed with sample build and receive orders.
2. Orders received without customer signed back will be regarded as agreement on the specifications.
3. Any specifications changes must be approved upon by both parties and a new revision of specifications shall be released to reflect the changes.



TAI-SAW TECHNOLOGY CO., LTD.

No. 3, Industrial 2nd Rd., Ping-Chen Industrial District,
Taoyuan, 324, Taiwan, R.O.C.

TEL: 886-3-4690038 FAX: 886-3-4697532

E-mail: tstsales@mail.taisaw.com Web: www.taisaw.com

SAW Filter 434.7MHz

MODEL NO.:TA1820A

REV. NO.:1.0

A. MAXIMUM RATING:

1. Input Power Level: 13 dBm
2. DC Voltage : 0V
3. Operating Temperature: -40°C to +105°C
4. Storage Temperature: -40°C to +105°C

RoHS Compliant
Lead free
Lead-free soldering

Electrostatic Sensitive Device (ESD)

B. ELECTRICAL CHARACTERISTICS:

Terminating source impedance (single) : $Z_s = 50 \Omega$

Terminating load impedance(single) : $Z_L = 50 \Omega$

Item	Unit	Min	Type.	Max
Center Frequency F_c	MHz	-	434.7	-
Minimum Insertion Loss α_{min}				
Incl. Loss in matching elements (434.165 ~ 435.235 MHz)	dB		2.2	2.9
Excl. Loss in matching elements (434.165 ~ 435.235 MHz)	dB		1.4	2.1
Pass Band (Relative to α_{min})				
434.165 ~ 435.235 MHz ¹			1.1	2.5
434.15 ~ 435.25 MHz ²			1.3	3.0
Relative Attenuation (Relative to α_{min}) α_{rel}				
10 ~ 350 MHz	dB	50	55	
350 ~ 414 MHz	dB	30	35	
414 ~ 425 MHz	dB	30	35	
425 ~ 433 MHz	dB	13	17	
436.7 ~ 437.3 MHz	dB	13	17	
437.3 ~ 438 MHz	dB	22	27	
438 ~ 330 MHz	dB	25	30	
330 ~ 446 MHz	dB	25	30	
446 ~ 455 MHz	dB	25	30	
455 ~ 480 MHz	dB	28	33	
480 ~ 800 MHz	dB	40	45	
800 ~ 1700 MHz	dB	52	57	
1700 ~ 2500 MHz	dB	42	47	
Package size	mm	SMD 3x3		

Impedance for pass band matching)				
Input: $Z_{IN} = L_{s1}/C_{p1}$	nH		82/8.2	
Output: $Z_{OUT} = L_{s2}/C_{p2}$	nH		68/1	

- 1) 433.913 ... 434.928 MHz for extended temperature range $-40\text{ }^{\circ}\text{C}$ to $+125\text{ }^{\circ}\text{C}$.
- 2) 433.898 ... 434.943 MHz for extended temperature range $-40\text{ }^{\circ}\text{C}$ to $+125\text{ }^{\circ}\text{C}$.
0805 Coillcraft CS series chip conductor is used for inductor.
0402 muRata GRM series is used for capacitor.

C.. TEST CIRCUIT:

The matching circuit is

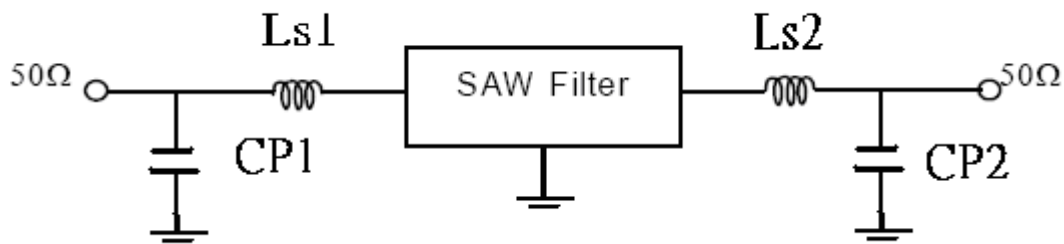

$L_{s1}=82\text{ nH}$; $L_{s2}=68\text{ nH}$; $C_{p1}=8.2\text{ pF}$; $C_{p2}=1\text{ pF}$

D. Frequency Characteristics :

S21 response: span 20MHz

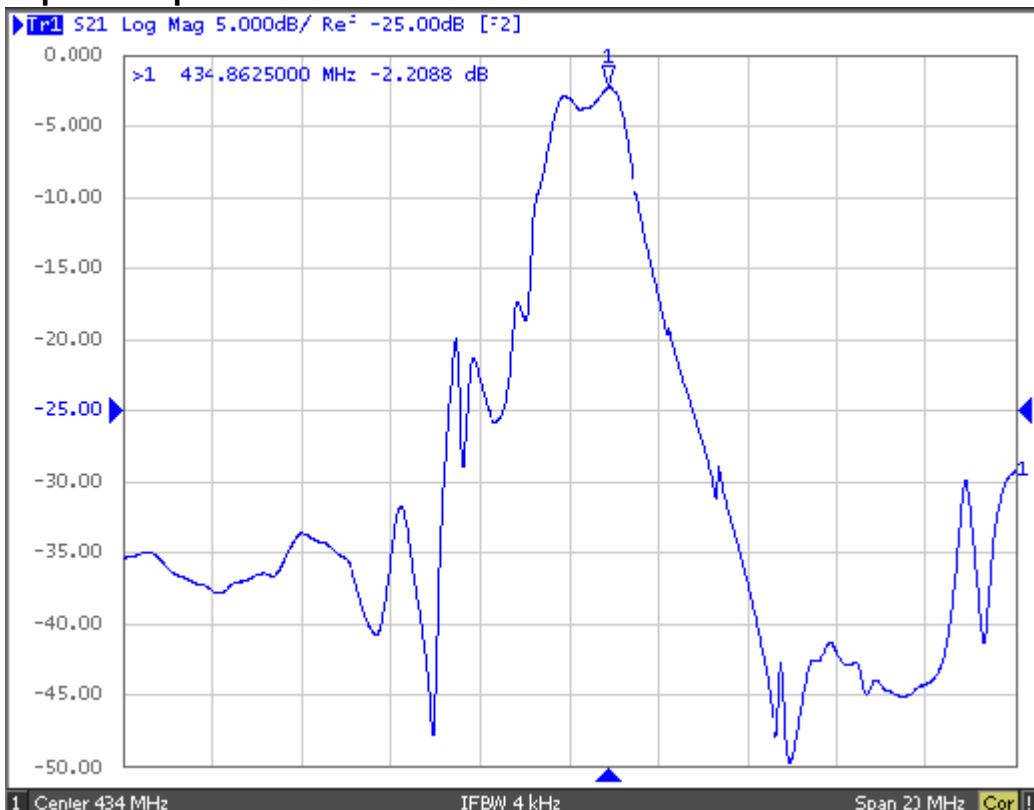

S21 response: span 5MHz

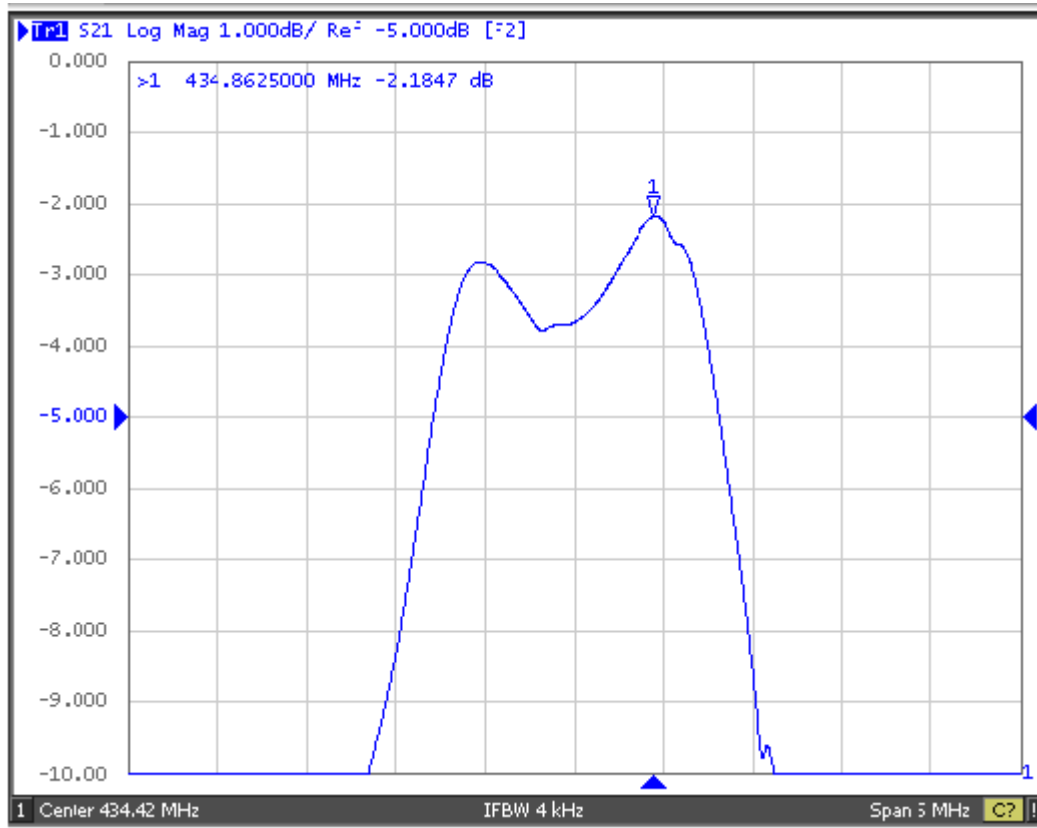

S21 response: 1MHz ~ 2.5GHz

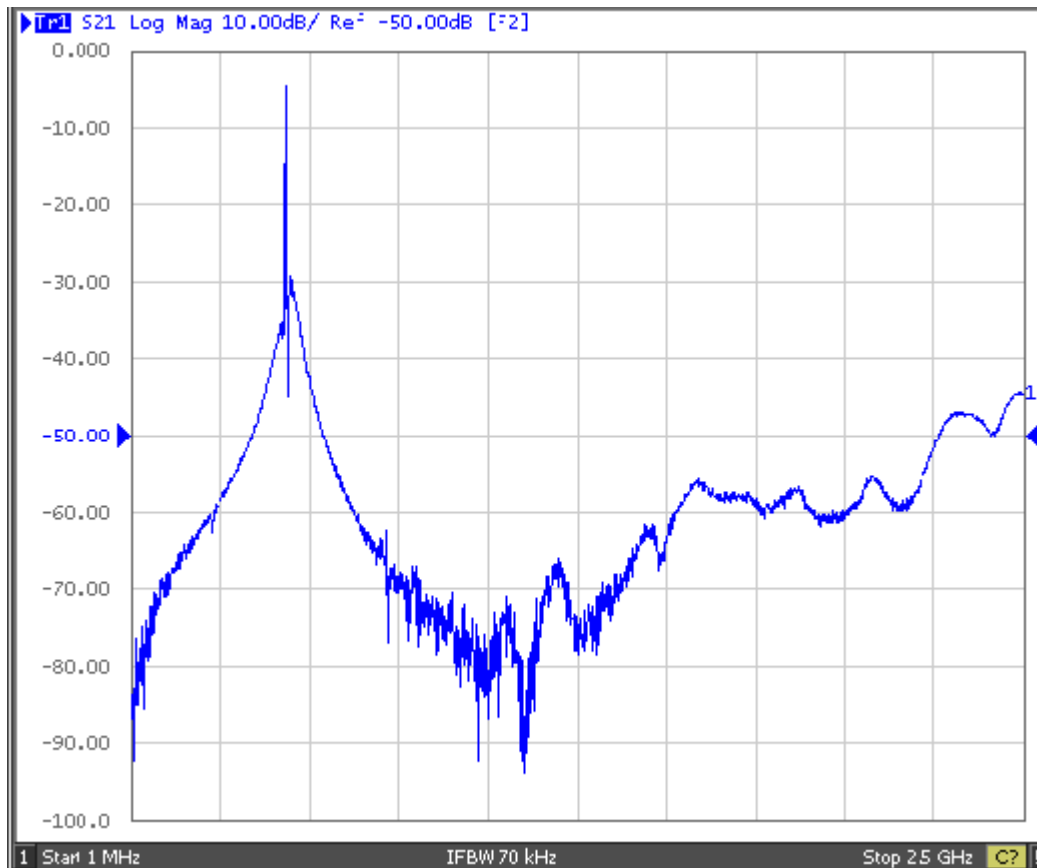

E.OUTLINE DRAWING:

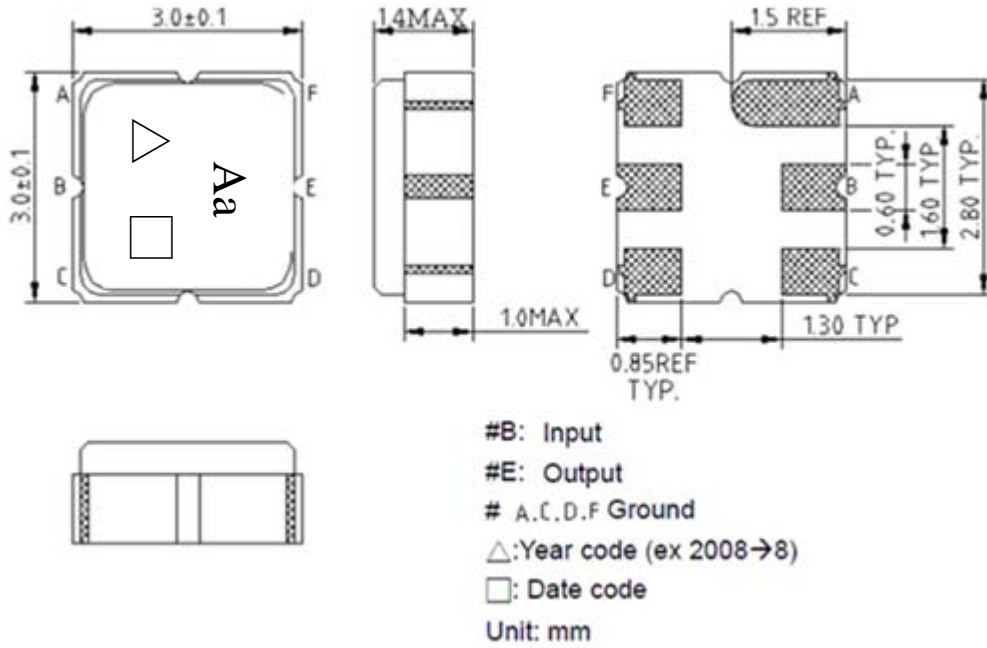

Data code : See the table

WK	01	02	...	26	27	28	...	52
Code	A	B	...	Z	a	b	...	z

△ Year code : See the table

Year	2008	2009	2010	2011	...	2019	2020
Code	8	9	0	1	...	9	0

F. PACKING:

1. REEL DIMENSION

(Please refer to FR-75D10 for packing quantity)

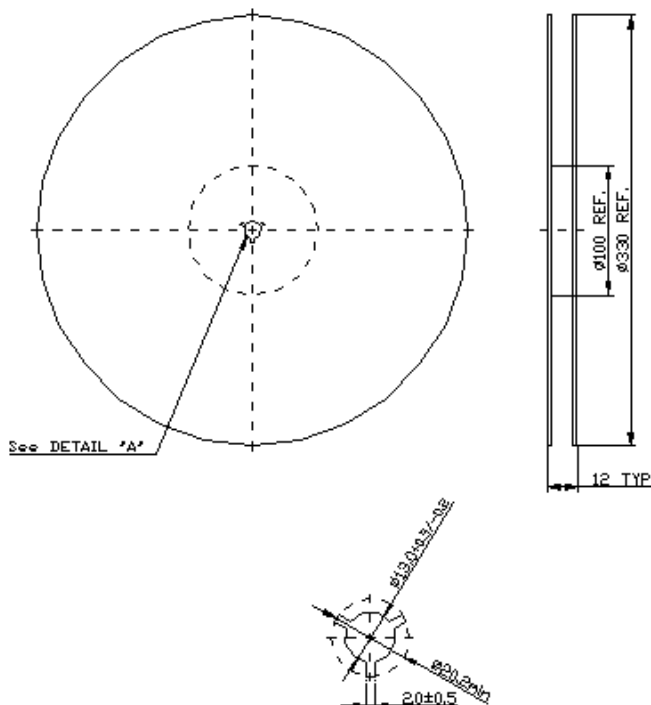

2. TAPE DIMENSION

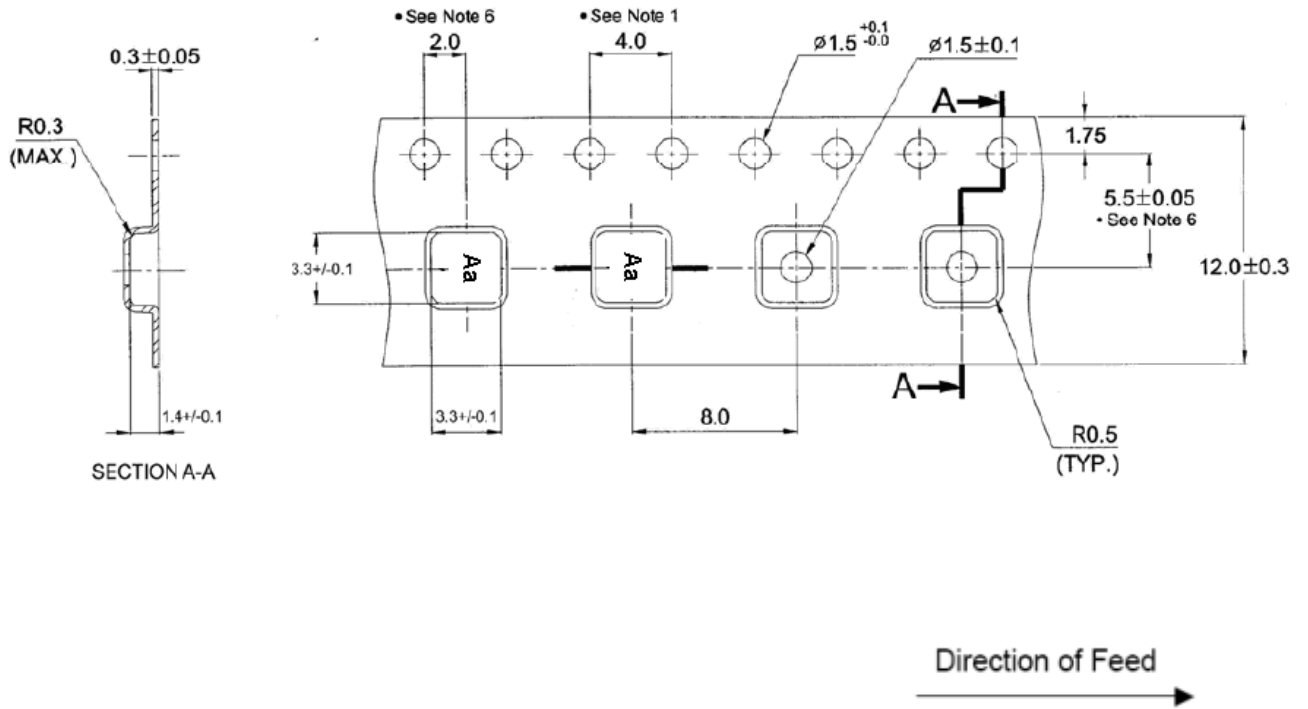

G. RECOMMENDED REFLOW PROFILE :

