

# DIESEL GENERATOR SET

## MTU 12V1600 DS660

400 – 230 V/600 kVA/50 Hz/Prime Power  
Series 1600 – MTU 12V1600



Optional equipment and finishing shown. Standard may vary.

### PRODUCT HIGHLIGHTS

#### // Benefits

- Industry-leading average load factor
- Low fuel consumption
- Emissions optimizations available
- High availability and reliability
- Outstanding load acceptance
- Long maintenance intervals

#### // Support

- Global product support offered

#### // Standards

- Engine-generator set is designed and manufactured in facilities certified to standards ISO 2008:9001
- Generator set complies to ISO 8528 and fullfills performance level G3
- Generator meets BS5000; NEMA MG 1; ISO; DIN EN and IEC standards
- NFPA 110

#### // Available optimizations

- TA-Luft (NO<sub>x</sub> < 1500mg/m<sup>3</sup> i.N.) optimized
- NEA Singapore for off road diesel engines (ORDE)
- Fuel optimized

#### // Wide Standard Scope of Supply

- 4P circuit breaker
- Island operation control panel
- Integrated fuel tank
- Industrial silencer (15 dB(A))
- Batteries & battery charger

#### // Complete range of accessories available

- Sound attenuated enclosure
- Fuel system accessories
- Control panel & ATS
- Range of additional electrical options

#### // Warranty

- Standard 36 months warranty after shipment

APPLICATION DATA<sup>①</sup>

## // Engine

Manufacturer	MTU
Model	12V1600G10F
Type	4-cycle
Arrangement	12V
Displacement: L	21
Bore: mm	122
Stroke: mm	150
Compression ratio	17.5
Rated rpm	1500
Engine governor	ECU 8
Gross power: kWm	524
Air cleaner	Dry

## // Fuel System

Max. fuel flow: L/h	342
Fuel tank capacity: OPU (EPU) in L	740 (950)
Autonomy: h	8

## // Fuel Consumption

	L/h
At 100% of power rating:	116.99
At 75% of power rating:	90.94
At 50% of power rating:	63.06

## // Liquid Capacity

Total oil system: L	72.5
Total coolant capacity: L	99

## // Generator

Generator brand	Mecc-Alte
Generator type	HM355B2
Insulation class	H-class
Bearing	single bearing
Enclosure	IP23 M
Voltage regulation	A.V.R. (electronic)
Exciting system	self-excited, brushless

## // Electrical

Electric system volts DC	24
Number of batteries	2
Capacity: Ah	2x 75

## // Air Requirements

Aspirating: m <sup>3</sup> /min	36
Cooling air flow: m <sup>3</sup> /s	11.7

## // Exhaust System

Gas temp. (stack): °C	482
Gas volume at stack temp.: m <sup>3</sup> /min	90
Maximum allowable back pressure: kPa	15

## // Cooling/Radiator System

Ambient capacity of radiator in OPU (EPU): °C	40 (35)
Pressure on rad. exhaust: kPa	0.2
Heat rejection to coolant: kW	231

① Technical data is for a fuel-optimized unit.

## STANDARD AND OPTIONAL FEATURES

### // System Ratings (kW/kVA)

	MTU 12V1600 DS660
	<b>Prime operation</b>
Voltage	400 V
Phase	Three phase
Hz	50
kWel*	480.0
kVA**	600
Rated AMPS	866.0

\* cos phi = 1,0

\*\* cos phi = 0,8

Also available for following voltages 380V & 415V - for details please contact your local MTU Onsite Energy Dealer.

### // Engine

- 4- strokes diesel engine
- Flywheel housing SAE 1
- Flywheel 14"
- Four-valve, overhead camshaft
- Piston cooling via oil spray nozzle
- Forged crankshaft & connecting rods
- Oil pan
- Lube oil circulation pump
- Dry exhaust manifolds
- Hot components and radiator guards
- Mobile components guards
- Lube oil filter

### // Fuel system

- Fuel main filter
- Fuel pre-filter with water separator
- Common rail fuel injection
- Integrated fuel tank (level sensor and drain cap incl.)
- Automatic fuel transfer pump
- Heavy-duty fuel pre-filter with water separator
- 3-way valve for fuel filling
- Fuel cooler

### // Generator

- 3-Phase, synchronous, brushless, self exciting, self regulating, self ventilating alternator
- Winding temperature sensors
- IP23 M protection degree
- IP23 protection cover
- Bearing temperature sensors
- Insulation class H
- Anti condensation heater
- Permanent magnet

### // Control Panel & Electric Options

- Control and power electric panel, with measurements devices and controller
- ATS (Automatic Transfer Switch)
- Control version for parallel operation
- Control version for synchronizing a single genset with mains
- Programmable timer for MM7 and MC7
- Remote display
- Expansion module for CAN communication
- Change over power supply for MC7
- Input Output/LED expansion modules for DeepSea controllers
- ModBus connection to customer systems TCP/IP
- Control version for synchronizing with mains without blackout
- Converter kits CAN to RS485/USB/LAN

Represents standard features

Represents optional features

## STANDARD AND OPTIONAL FEATURES, CONTINUATION

---

### // Circuit Breaker/Power Distribution

- 4 poles manual circuit breaker  
(motorized with DeepSea controllers)

### // Starting/Charging System

- 24V electric system
- Starting batteries installed
- Pre-heating resistance/jacket water heater
- Battery charging alternator
- Battery disconnecter
- Battery charger

### // Air Intake System

- Exhaust turbochargers
- Set of dry-type air filters with containment indicator
- Intercooler, integrated in radiator
- Heavy duty air filter with automatic dust evacuation

### // Exhaust System

- Industrial silencer 15 dB(A)
- Residential silencer 35 dB(A)
- Exhaust bellows

### // Cooling System

- Coolant circulation pump
- Front type radiator for jacket water and charge aircooling circuit with integrated expansion tank
- Engine mounted fan drive

### // Mounting System

- Mounted on steel base frame
- Resilient mounting of engine and generator

### // Enclosures

- Sound proof enclosure
- Socket box
- Increased fuel tank capacity

### // Documentation & Certifications

- Genset & component manuals
- Maintenance schedule
- CE-certification for EU
- Fluids and lubricants specification

## WEIGHTS AND DIMENSIONS

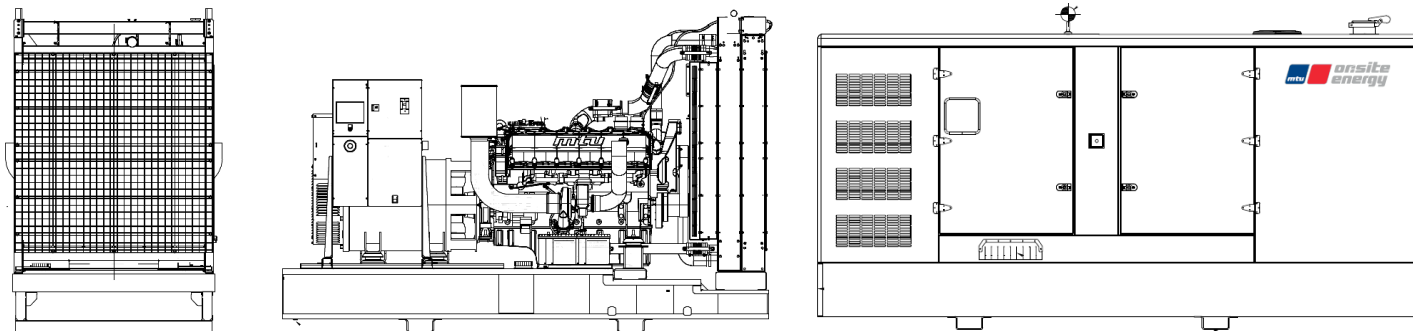

Drawing above for illustration purposes only, based on standard open and enclosed power 400 Volt engine-generator set. Lengths may vary with other voltages. Do not use for installation design. See website for unit specific template drawings.

System	Dimensions (LxWxH)	Weight (wet/with standard accessories)
Open Power Unit (OPU)	3.600 x 1.604 x 2.121 mm	4.529 kg
Enclosed Power Unit	5.000 x 2.100 x 2.369 mm	6.739 kg

Consult the factory for accurate weights and dimensions for your specific engine-generator set. Lengths may vary with other voltages. Do not use for installation design.

## SOUND DATA

Unit Type	
Open Power Unit: dB(A)	on request
Enclosed Power Unit: dB(A)	72.2

Sound data is provided at 7m for 75% prime power.

## RATING DEFINITIONS AND CONDITIONS

- // Prime power ratings apply to installations where utility power is unavailable or unreliable. At varying load, the number of generator set operating hours is unlimited. A 10% overload capacity is available for one hour in twelve. Ratings are in accordance with ISO 8528-1, ISO 3046-1, BS 5514, AS 2789 and DIN 6271. Average load factor: < 75%.
- // Derating factor:
  - Altitude: Consult your local MTU Onsite Energy Power Generation distributor for altitude deratings.
  - Temperature: Consult your local MTU Onsite Energy Power Generation distributor for temperature deratings.

Rated power for reference conditions at 25°C and 100m above sea level.

Materials and specifications subject to change without notice.