

REPLACEMENT TYPE : 2SA1179
FEATURES

- High Breakdown Voltage

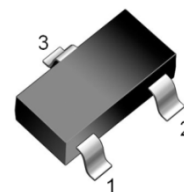

SOT-23 MARKING:M

1: BASE 2:EMITTER 3: COLLECTOR

MAXIMUM RATINGS ($T_A = 25^\circ\text{C}$ unless otherwise noted)

Parameter	Symbol	Value	Unit
Collector-Base Voltage	V_{CBO}	-55	V
Collector-Emitter Voltage	V_{CEO}	-50	V
Emitter-Base Voltage	V_{EBO}	-5	V
Collector Current-Continuous	I_C	-150	mA
Collector Power Dissipation	P_C	200	mW
Junction Temperature	T_J	150	$^\circ\text{C}$
Storage Temperature	T_{stg}	-55~+150	$^\circ\text{C}$

ELECTRICAL CHARACTERISTICS ($T_A = 25^\circ\text{C}$ unless otherwise noted)

Parameter	Symbol	Test conditions	Min	Typ	Max	Unit
Collector-Base Breakdown Voltage	V_{CBO}	$I_C = -10\mu\text{A}, I_E = 0$	-55			V
Collector-Emitter Breakdown Voltage	V_{CEO}	$I_C = -1\text{mA}, I_B = 0$	-50			V
Emitter-Base Breakdown Voltage	V_{EBO}	$I_E = -10\mu\text{A}, I_C = 0$	-5			V
Collector Cut-off Current	I_{CBO}	$V_{CB} = -35\text{V}, I_E = 0$			-0.1	μA
Emitter Cut-off Current	I_{EBO}	$V_{EB} = -4\text{V}, I_C = 0$			-0.1	μA
DC Current Gain	h_{FE}	$V_{CE} = -6\text{V}, I_C = -1\text{mA}$	200		400	
Collector-Emitter Saturation Voltage	$V_{CE(sat)}$	$I_C = -50\text{mA}, I_B = -5\text{mA}$			-0.5	V
Base -Emitter Saturation Voltage	$V_{BE(sat)}$	$I_C = -50\text{mA}, I_B = -5\text{mA}$			-1.0	V
Transition Frequency	f_T	$V_{CE} = -6\text{V}, I_C = -10\text{mA}$		180		MHz
Collector Output Capacitance	C_{OB}	$V_{CB} = -6\text{V}, I_E = 0, f = 1\text{MHz}$		4		pF

Typical Characteristics

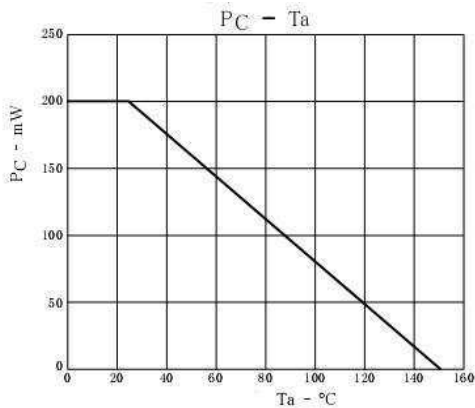
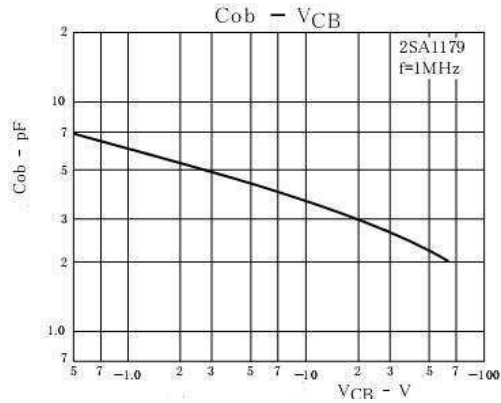
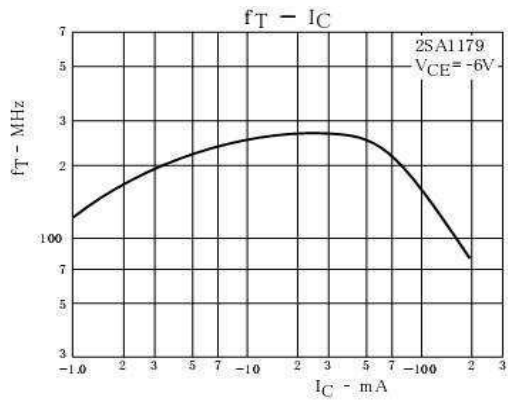
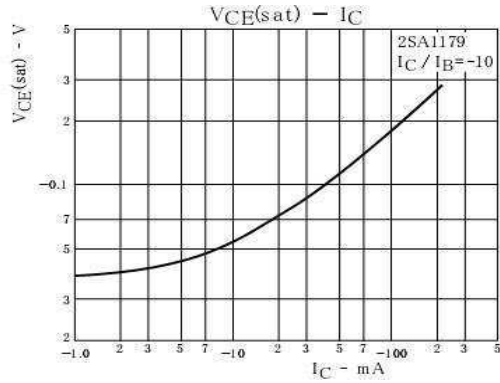
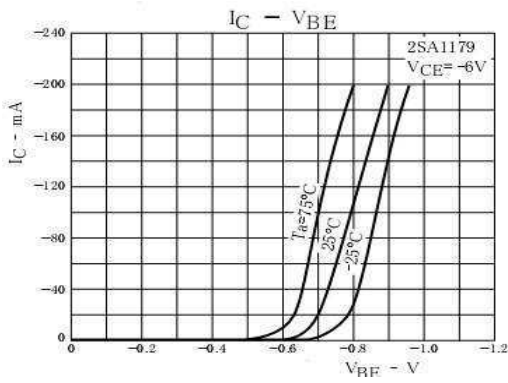
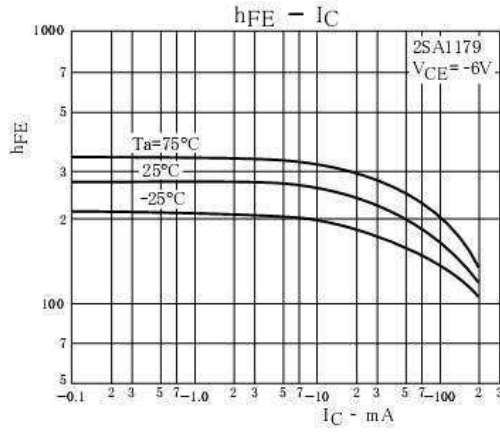
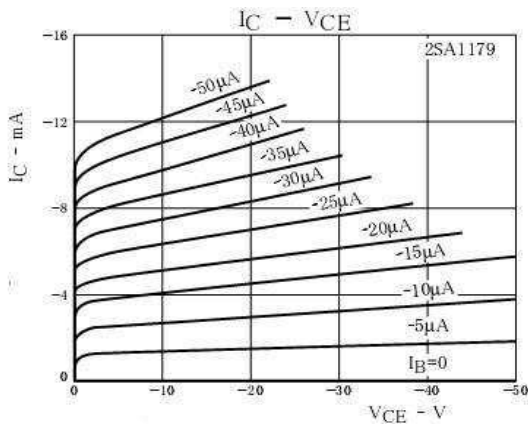

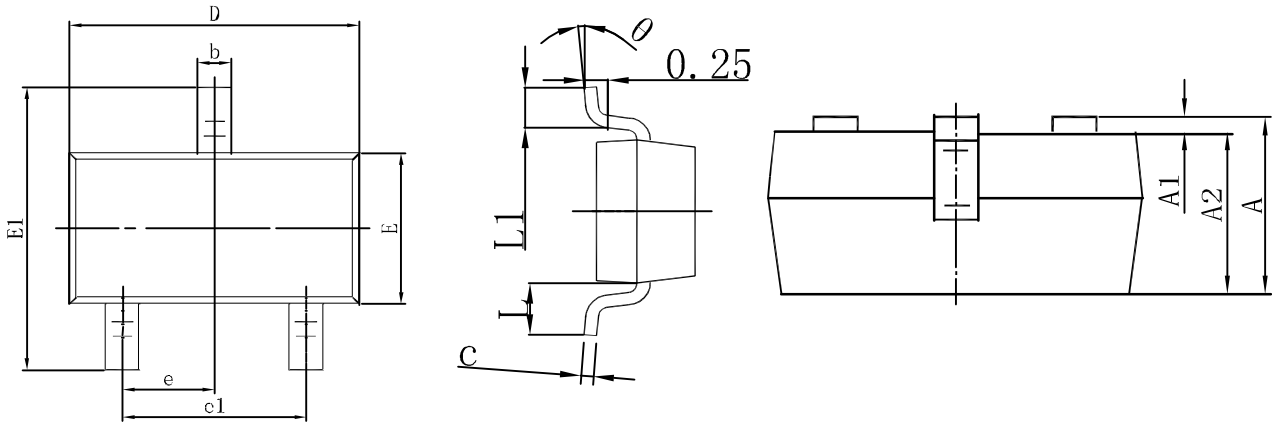
SOT-23 Package Outline Dimensions

Symbol	Dimensions In Millimeters		Dimensions In Inches	
	Min.	Max.	Min.	Max.
A	0.900	1.150	0.035	0.045
A1	0.000	0.100	0.000	0.004
A2	0.900	1.050	0.035	0.041
b	0.300	0.500	0.012	0.020
c	0.080	0.150	0.003	0.006
D	2.800	3.000	0.110	0.118
E	1.200	1.400	0.047	0.055
E1	2.250	2.550	0.089	0.100
e	0.950 TYP		0.037 TYP	
e1	1.800	2.000	0.071	0.079
L	0.550 REF		0.022 REF	
L1	0.300	0.500	0.012	0.020
θ	0°	8°	0°	8°

SOT-23 Embossed Carrier Tape

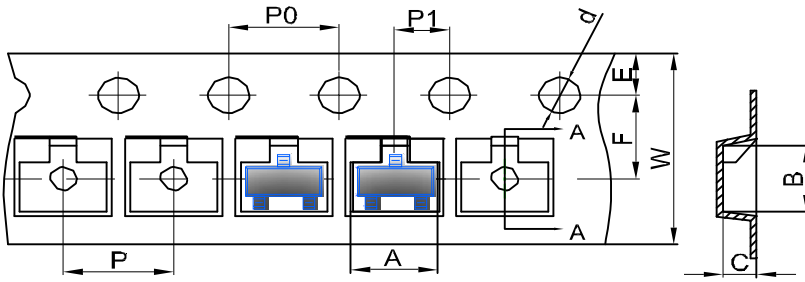

DIMENSIONS ARE IN MILLIMETER										
TYPE	A	B	C	d	E	F	P0	P	P1	W
SOT-23	3.15	2.77	1.22	φ1.50	1.75	3.50	4.00	4.00	2.00	8.00
TOLERANCE	±0.1	±0.1	±0.1	±0.1	±0.1	±0.1	±0.1	±0.1	±0.1	±0.1

SOT-23 Tape Leader and Traller

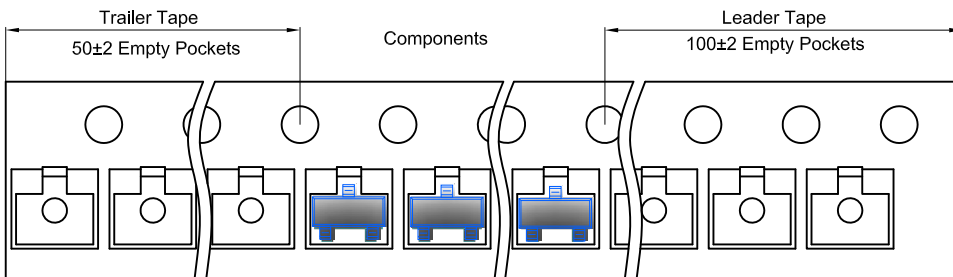

SOT-23 Reel

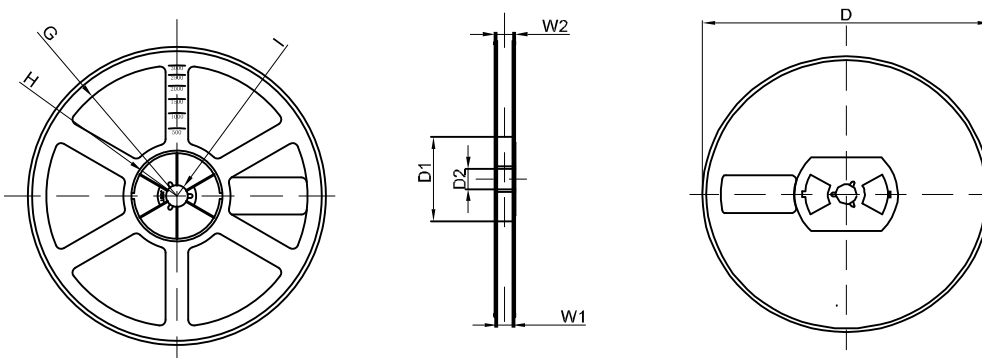

DIMENSIONS ARE IN MILLIMETER								
REEL OPTION	D	D1	D2	G	H	I	W1	W2
7" DIA	φ178	54.40	13.00	R78	R25.60	R6.50	9.50	12.30
TOLERANCE	±2	±1	±1	±1	±1	±1	±1	±1