



DTC113T

NPN SILICON TRANSISTOR

NPN DIGITAL TRANSISTOR (BUILT-IN BIAS RESISTORS)

FEATURES

- * Built-in bias resistors that implies easy ON/OFF applications.
- * The bias resistors are thin-film resistors with complete isolation to allow negative input.

EQUIVALENT CIRCUIT

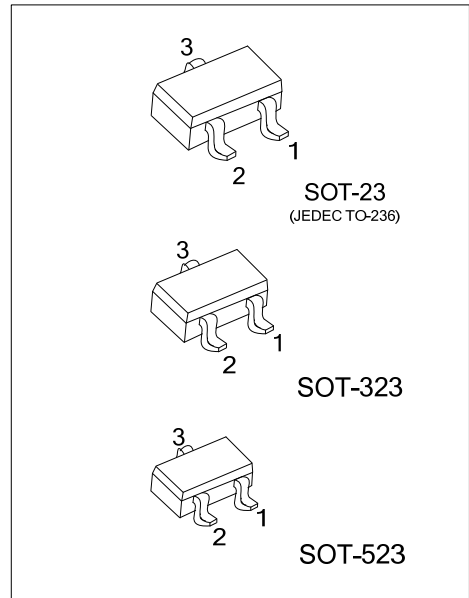
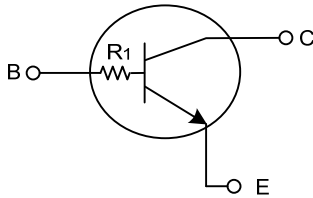

ORDERING INFORMATION

Ordering Number	Package	Pin Assignment			Packing
		1	2	3	
DTC113TG-AE3-R	SOT-23	E	B	C	Tape Reel
DTC113TG-AL3-R	SOT-323	E	B	C	Tape Reel
DTC113TG-AN3-R	SOT-523	E	B	C	Tape Reel

Note: Pin Assignment: E: Emitter B: Base C: Collector

<p>DTC113TG-AE3-R</p> <p>(1) Packing Type</p> <p>(2) Package Type</p> <p>(3) Green Package</p>	<p>(1) R: Tape Reel</p> <p>(2) AE3: SOT-23, AL3: SOT-323, AN3: SOT-523</p> <p>(3) G: Halogen Free and Lead Free</p>
--	---

MARKING

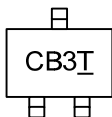

■ ABSOLUTE MAXIMUM RATINGS ($T_A=25^\circ\text{C}$, unless otherwise specified)

PARAMETER		SYMBOL	RATINGS	UNIT
Collector to Base Voltage		V_{CB0}	50	V
Emitter to Base Voltage		V_{EB0}	6	V
Collector to Emitter voltage		V_{CEO}	50	V
Collector Current		I_C	100	mA
Peak Collector Current		I_{CM}	200	mA
Collector Power Dissipation	SOT-23/SOT-323	P_C	200	mW
	SOT-523		150	
Junction Temperature		T_J	+150	$^\circ\text{C}$
Storage Temperature		T_{STG}	-55~+150	$^\circ\text{C}$

Note: Absolute maximum ratings are those values beyond which the device could be permanently damaged.

Absolute maximum ratings are stress ratings only and functional device operation is not implied.

■ ELECTRICAL CHARACTERISTICS ($T_A=25^\circ\text{C}$, unless otherwise specified)

PARAMETER	SYMBOL	TEST CONDITIONS	MIN	TYP	MAX	UNIT
Collector-Emitter Breakdown Voltage	BV_{CEO}	$I_C=100\mu\text{A}$, $R_{BE}=\infty$	50			V
Collector Cut-off Current	I_{CBO}	$V_{CB}=50\text{V}$, $I_E=0$			0.1	μA
DC Current Gain	h_{FE}	$V_{CE}=5\text{V}$, $I_C=1\text{mA}$	100			
Collector-Emitter Saturation Voltage	$V_{CE(SAT)}$	$I_C=10\text{mA}$, $I_B=0.5\text{mA}$			0.3	V
Input Resistance	R_i		0.7	1.0	1.3	k Ω
Current Gain Bandwidth Product	f_T	$V_{CE}=6\text{V}$, $I_E=-10\text{mA}$		200		MHz

TYPICAL CHARACTERISTICS

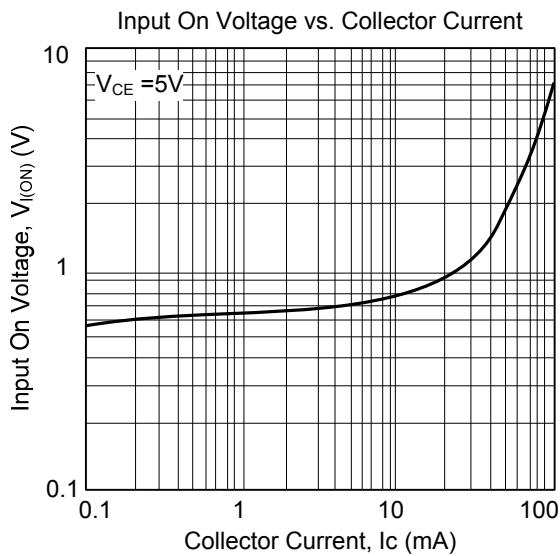
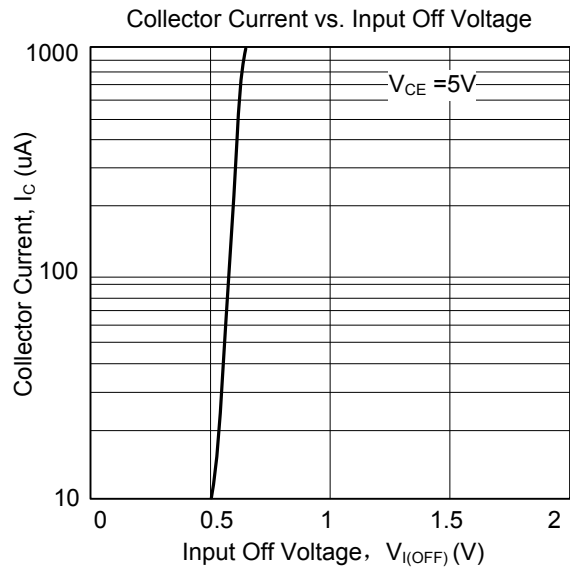
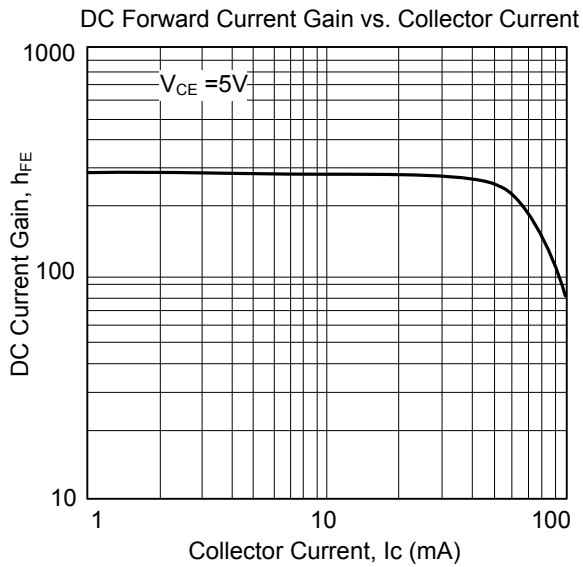

UTC assumes no responsibility for equipment failures that result from using products at values that exceed, even momentarily, rated values (such as maximum ratings, operating condition ranges, or other parameters) listed in products specifications of any and all UTC products described or contained herein. UTC products are not designed for use in life support appliances, devices or systems where malfunction of these products can be reasonably expected to result in personal injury. Reproduction in whole or in part is prohibited without the prior written consent of the copyright owner. The information presented in this document does not form part of any quotation or contract, is believed to be accurate and reliable and may be changed without notice.