

isc N-Channel MOSFET Transistor

2SK754

DESCRIPTION

- Drain Current $-I_D=10A @ T_C=25^\circ C$
- Drain Source Voltage-
: $V_{DSS}= 160V(\text{Min})$

APPLICATIONS

- High speed power switching

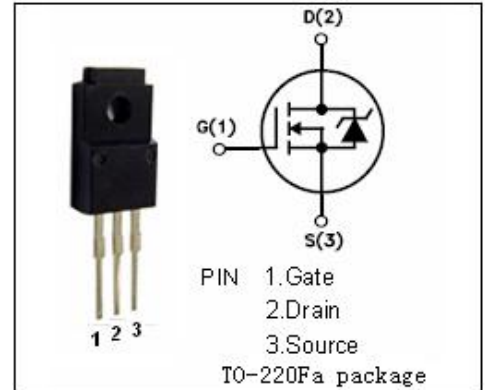

ABSOLUTE MAXIMUM RATINGS($T_a=25^\circ C$)

SYMBOL	ARAMETER	VALUE	UNIT
V_{DSS}	Drain-Source Voltage ($V_{GS}=0$)	160	V
V_{GS}	Gate-Source Voltage	± 20	V
I_D	Drain Current-continuous@ $TC=25^\circ C$	10	A
P_{tot}	Total Dissipation@ $TC=25^\circ C$	50	W
T_j	Max. Operating Junction Temperature	150	$^\circ C$
T_{stg}	Storage Temperature Range	-55~150	$^\circ C$

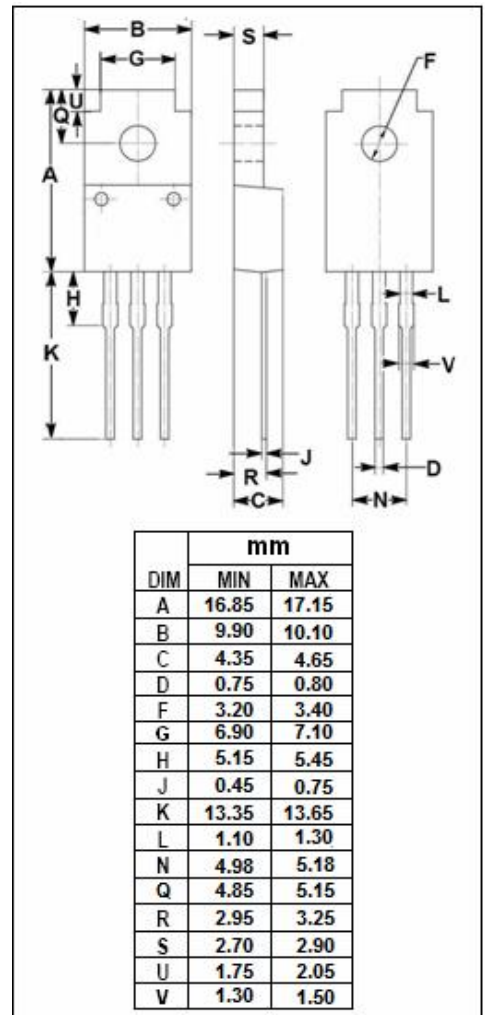

isc N-Channel Mosfet Transistor**2SK754****• ELECTRICAL CHARACTERISTICS (T_C=25°C)**

SYMBOL	PARAMETER	CONDITIONS	MIN	TYP	MAX	UNIT
V _{(BR)DSS}	Drain-Source Breakdown Voltage	V _{GS} =0; I _D = 10mA	160			V
V _{GS(th)}	Gate Threshold Voltage	V _{DS} =10 V _{GS} ; I _D =1mA	1.0		5.0	V
R _{DS(on)}	Drain-Source On-stage Resistance	V _{GS} =10V; I _D = 5A			0.22	Ω
I _{GSS}	Gate Source Leakage Current	V _{GS} = ±16V; V _{DS} = 0			±10	uA
I _{DSS}	Zero Gate Voltage Drain Current	V _{DS} =120V; V _{GS} = 0			250	uA
V _{SD}	Diode Forward Voltage	I _F =10A; V _{GS} =0		1.0		V