

1. Mechanical Dimensions:

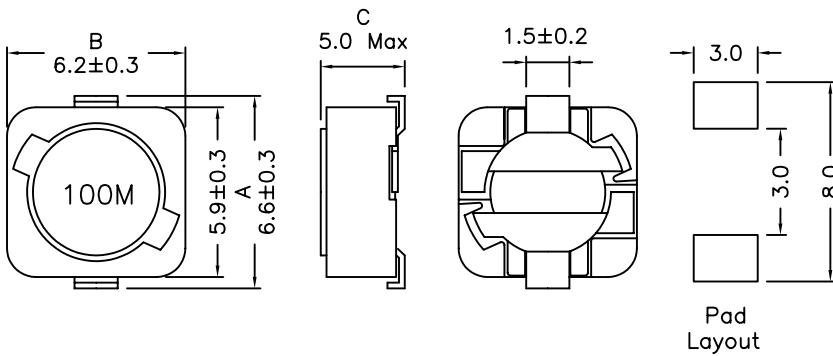

2. Schematic:

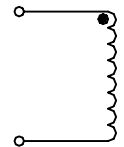

3. Electrical Specification:

OCL: 10uH ±10% @1KHz 1.0V
 Rated Current: 1.35 Adc (based on 10% drop in OCL)
 DCR: 0.12 Ohms Max.

Notes:

1. Solderability: Leads shall meet MIL-STD-202, Method 208D for solderability.
2. Flammability: UL94V-0
3. ASTM oxygen index: > 28%
4. Insulation System: Class F 155°C. UL file E151556
5. Operating Temperature Range: All listed parameters are to be within tolerance from -40°C to +85°C
6. Storage Temperature Range: -55°C to +125°C
7. Aqueous wash compatible

DOC. REV: A/1

XFMRS Inc.	Title: HIGH CURRENT SELF-LEADED SMT INDUCTORS		
	UNLESS OTHERWISE SPECIFIED	P/N: XFTPRH64B-100M	REV. A
TOLERANCES:	DWN.	李小锋	Mar-27-02
.xx ±0.25	CHK.	廖玉坤	Mar-27-02
Dimensions in MM	APP.	BW	Mar-27-02