



Is Now Part of



ON Semiconductor®

To learn more about ON Semiconductor, please visit our website at
www.onsemi.com

Please note: As part of the Fairchild Semiconductor integration, some of the Fairchild orderable part numbers will need to change in order to meet ON Semiconductor's system requirements. Since the ON Semiconductor product management systems do not have the ability to manage part nomenclature that utilizes an underscore (_), the underscore (_) in the Fairchild part numbers will be changed to a dash (-). This document may contain device numbers with an underscore (_). Please check the ON Semiconductor website to verify the updated device numbers. The most current and up-to-date ordering information can be found at www.onsemi.com. Please email any questions regarding the system integration to Fairchild_questions@onsemi.com.

ON Semiconductor and the ON Semiconductor logo are trademarks of Semiconductor Components Industries, LLC dba ON Semiconductor or its subsidiaries in the United States and/or other countries. ON Semiconductor owns the rights to a number of patents, trademarks, copyrights, trade secrets, and other intellectual property. A listing of ON Semiconductor's product/patent coverage may be accessed at www.onsemi.com/site/pdf/Patent-Marking.pdf. ON Semiconductor reserves the right to make changes without further notice to any products herein. ON Semiconductor makes no warranty, representation or guarantee regarding the suitability of its products for any particular purpose, nor does ON Semiconductor assume any liability arising out of the application or use of any product or circuit, and specifically disclaims any and all liability, including without limitation special, consequential or incidental damages. Buyer is responsible for its products and applications using ON Semiconductor products, including compliance with all laws, regulations and safety requirements or standards, regardless of any support or applications information provided by ON Semiconductor. "Typical" parameters which may be provided in ON Semiconductor data sheets and/or specifications can and do vary in different applications and actual performance may vary over time. All operating parameters, including "Typicals" must be validated for each customer application by customer's technical experts. ON Semiconductor does not convey any license under its patent rights nor the rights of others. ON Semiconductor products are not designed, intended, or authorized for use as a critical component in life support systems or any FDA Class 3 medical devices or medical devices with a same or similar classification in a foreign jurisdiction or any devices intended for implantation in the human body. Should Buyer purchase or use ON Semiconductor products for any such unintended or unauthorized application, Buyer shall indemnify and hold ON Semiconductor and its officers, employees, subsidiaries, affiliates, and distributors harmless against all claims, costs, damages, and expenses, and reasonable attorney fees arising out of, directly or indirectly, any claim of personal injury or death associated with such unintended or unauthorized use, even if such claim alleges that ON Semiconductor was negligent regarding the design or manufacture of the part. ON Semiconductor is an Equal Opportunity/Affirmative Action Employer. This literature is subject to all applicable copyright laws and is not for resale in any manner.

FSA2269 / FSA2269TS — Low-Voltage Dual-SPDT (0.4 Ω) Analog Switch with Negative Swing Audio Capability

Features

- 0.4 Ω Typical On Resistance (R_{ON}) for +3.0 V Supply
- 0.25 Ω Maximum R_{ON} Flatness for +3.0 V Supply
- -3 db Bandwidth: > 50 MHz
- Low- I_{CCT} Current Over an Expanded Control Input Range
- Packaged in 10-Lead MicroPak™, UMLP, and WLCSP
- Power-Off Protection on Common Ports
- Broad V_{CC} Operating Range: 1.65 to 4.5 V
- Noise Immunity Termination Resistors in FSA2269TS

Applications

- Cell Phone, PDA, Digital Camera, and Notebook
- LCD Monitor, TV, and Set-Top Box

Description

The FSA2269 is a high-performance, dual Single-Pole Double-Throw (SPDT) analog switch with negative swing audio capability. The FSA2269 features ultra-low R_{ON} of 0.4 Ω (typical) at 3.0 V V_{CC} . The FSA2269 operates over a wide V_{CC} range of 1.65 V to 4.5 V, is fabricated with sub-micron CMOS technology to achieve fast switching speeds, and is designed for break-before-make operation. The select input is TTL-level compatible.

The FSA2269 features very low quiescent current even when the control voltage is lower than the V_{CC} supply. This feature suits mobile handset applications by allowing direct interface with baseband processor general-purpose I/Os with minimal battery consumption.

The FSA2269TS includes termination resistors that improve noise immunity during overshoot excursions, off-isolation coupling, or “pop-minimization.”

Ordering Information

Part Number	Top Mark	Package Description
FSA2269L10X	HL	10-Lead, MicroPak, JEDEC MO-255, 1.6 x 2.1 mm
FSA2269UMX	HP	10-Lead, Quad Ultrathin Molded Leadless Package (UMLP), 1.4 x 1.8 mm, 0.4 mm Pitch
FSA2269TSL10X	HU	10-Lead, MicroPak, JEDEC MO-255, 1.6 x 2.1 mm
FSA2269TSUMX	HT	10-Lead, Quad Ultrathin Molded Leadless Package (UMLP), 1.4 x 1.8 mm, 0.4 mm Pitch
FSA2269UCX	N9	12-Ball, Wafer-Level Chip Scale Package (WLCSP), 1.2 x 1.6 mm, 0.4 mm Pitch

Analog Symbols

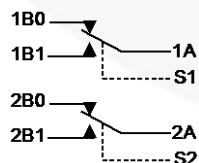

Figure 1. FSA2269

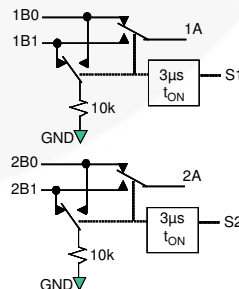

Figure 2. FSA2269TS (with Slow Turn On)

Pin Configuration

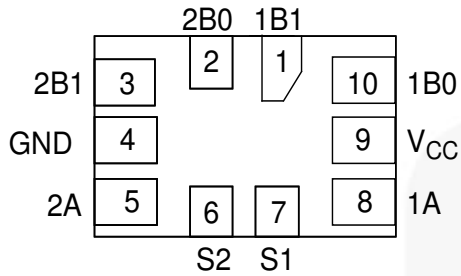

Figure 3. 10-Pin UMLP (Top Through View)

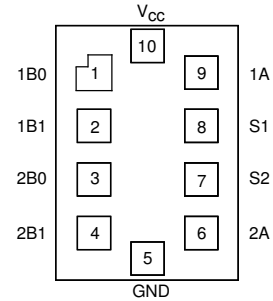

Figure 4. 10-Pin MicroPak™ (Top Through View)

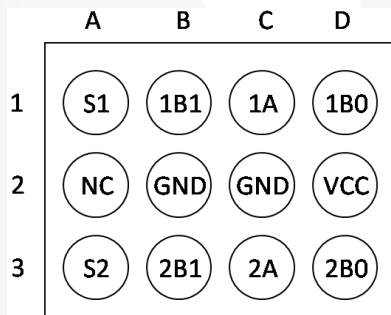

Figure 5. 12-Ball WLCSP (Bump Side View)

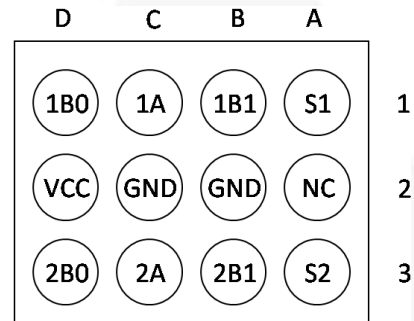

Figure 6. 12-Ball WLCSP (Top Side View)

Pin Descriptions

Pin # UMLP	Pin # Micropak	WLCSP	Name	Description
1	2	B1	1B1	Data Ports
2	3	D3	2B0	Data Ports
3	4	B3	2B1	Data Ports
4	5	B2, C2	GND	Ground
5	6	C3	2A	Data Ports
6	7	A3	S2	Switch Select Pins
7	8	A1	S1	Switch Select Pins
8	9	C1	1A	Data Ports
9	10	D2	V _{CC}	Supply Voltage
10	1	D1	1B0	Data Ports

Truth Table

Control Input, S _n	Function
LOW Logic Level	nB0 connected to nA (FSA2269/2269TS); nB1 terminated to GND (FSA2269TS only)
HIGH Logic Level	nB1 connected to nA (FSA2269/2269TS); nB0 terminated to GND (FSA2269TS only)

Absolute Maximum Ratings

Stresses exceeding the absolute maximum ratings may damage the device. Functional operation above the recommended operating conditions is not implied. In addition, extended exposure to stresses above the recommended operating conditions may affect device reliability. Absolute maximum ratings are stress ratings only.

Symbol	Parameter		Min.	Max.	Unit
V _{CC}	Supply Voltage		-0.5	5.5	V
V _{SW}	Switch I/O Voltage ⁽¹⁾	1B0, 1B1, 2B0, 2B1, 1A, 2A Pins	V _{CC} -4.6	5.5	V
V _{CNTRL}	Control Input Voltage ⁽¹⁾	S1, S2	-0.5	V _{CC} +0.3	V
I _{SW}	Switch I/O Current (Continuous)			350	mA
I _{SWPEAK}	Peak Switch Current	Pulsed at 1ms Duration, <10% Duty Cycle		500	mA
T _{STG}	Storage Temperature Range		-65	+150	°C
T _J	Maximum Junction Temperature			+150	°C
T _L	Lead Temperature	Soldering, 10 Seconds		+260	°C
MSL	Moisture Sensitivity Level, JEDEC J-STD-020A		1		
ESD	Human Body Model, JEDEC: JESD22-A114	I/O to GND		12	kV
		I/O to GND FSA2269UCX		11	
		Power to GND		8	
		All Other Pins		7	
	Charged Device Model, JEDEC: JESD22-C101			2	

Note:

- Input and output negative ratings may be exceeded if input and output diode current ratings are observed.

Recommended Operating Conditions

The Recommended Operating Conditions table defines the conditions for actual device operation. Recommended operating conditions are specified to ensure optimal performance to the datasheet specifications. Fairchild does not recommend exceeding them or designing to absolute maximum ratings.

Symbol	Parameter	Min.	Max.	Unit
V _{CC}	Supply Voltage ⁽²⁾	1.65	4.50	V
V _{S1, S2}	Control Input Voltage	0V	V _{CC}	V
V _{SW}	Switch I/O Voltage	V _{CC} -4.3	V _{CC}	V
T _A	Operating Temperature	-40	+85	°C

Note:

- For 4.5 V operation, SEL frequency (pins S1 & S2) should not exceed 100 Hz and 50 ns edge rate.

DC Electrical Characteristics

All typical values are $T_A=25^\circ\text{C}$ unless otherwise specified.

Symbol	Parameter	Conditions	V_{CC} (V)	$T_A=+25^\circ\text{C}$			$T_A=-40$ to $+85^\circ\text{C}$		Unit
				Min.	Typ.	Max.	Min.	Max.	
V_{IH}	Input Voltage High		3.60 to 4.50				1.70		V
			3.00 to 3.60				1.50		
			2.70 to 3.00				1.35		
			2.30 to 2.70				1.30		
			1.65 to 1.95				0.90		
V_{IL}	Input Voltage Low		3.60 to 4.50					0.7	V
			2.70 to 3.60					0.5	
			2.30 to 2.70					0.4	V
			1.65 to 1.95					0.4	
I_{IN}	Control Input Leakage (S1, S2)	$V_{IN}=0$ to V_{CC}	1.65 to 4.50				-0.5	0.5	μA
$I_{NO(OFF)}$, $I_{NC(OFF)}$	Off Leakage Current of Port nB0 and nB1 (FSA2269 only)	nA=0.5 V, $V_{CC}=0.5$ V nB0 or nB1= $V_{CC}-0.5$ V, 0.5 V, or Floating Figure 8	1.95 to 4.50	-50		50	-250	250	nA
$I_{A(ON)}$	On Leakage Current of Port nA	nA=0.5 V, $V_{CC}=0.5$ V nB0 or nB1= $V_{CC}-0.5$ V, 0.5 V, or Floating Figure 9	1.95 to 4.50	-20		20	-150	150	nA
I_{OFF}	Power-Off Leakage Current (Common Port Only 1A, 2A) (FSA2269)	Common Port (1A, 2A), $V_{IN}=0$ V to 4.5 V, $V_{CC}=0$ V nB0, nB1=Floating	0					± 1	μA
	Power-Off Leakage Current (Common Port Only 1A, 2A) (FSA2269TS)	Common Port (1A, 2A), $V_{IN}=0$ V to 4.5 V, $V_{CC}=0$ V nB0, nB1=0 V or Floating	0					± 45	μA
R_{ON}	Switch On Resistance ^(3,6)	$I_{ON}=100$ mA, nB0 or nB1=0.7 V, 3.6 V, 4.5 V, Figure 7	4.50		0.30				Ω
		$I_{ON}=100$ mA, nB0 or nB1=0.7 V, 3.6 V, Figure 7	3.00		0.40			0.80	
		$I_{ON}=100$ mA, nB0 or nB1=0V, 0.7 V, 1.6 V, 2.3 V, Figure 7	2.30		0.52				
		$I_{ON}=100$ mA, nB0 or nB1=0V, 0.7 V, 1.65 V, Figure 7	1.65		1.00				
ΔR_{ON}	On Resistance Matching Between Channels ⁽⁴⁾	$I_{ON}=100$ mA, nB0 or nB1=0.7 V	4.50		0.04			0.13	Ω
			3.00		0.06			0.13	
			2.30		0.12				
			1.65		1.00				

Continued on the following page...

DC Electrical Characteristics (Continued)

All typical values are $T_A=25^\circ\text{C}$ unless otherwise specified.

Symbol	Parameter	Conditions	V_{CC} (V)	$T_A=+25^\circ\text{C}$			$T_A=-40$ to $+85^\circ\text{C}$		Unit
				Min.	Typ.	Max.	Min.	Max.	
$R_{\text{FLAT(ON)}}$	On Resistance Flatness ⁽⁵⁾	$I_{\text{OUT}}=100$ mA, nB0 or nB1=0V to V_{CC}	4.50					0.25	Ω
			3.00					0.25	
			2.30		0.5				
			1.65		0.6				
R_{TERM}	Internal Termination Resistors ⁽⁶⁾ (FSA2269TS only)				10				k Ω
I_{CC}	Quiescent Supply Current	$V_{\text{IN}}=0$ or V_{CC} , $I_{\text{OUT}}=0$	4.50	-100		100	-500	500	nA
I_{CCT}	Increase in I_{CC} per Input	Input at 2.6 V	4.50		3.0			10.0	μA
		Input at 1.8 V			7.0			15.0	

Notes:

3. On resistance is determined by the voltage drop between A and B pins at the indicated current through the switch.
4. $\Delta R_{\text{ON}}=R_{\text{ON max}} - R_{\text{ON min}}$ measured at identical V_{CC} , temperature, and voltage.
5. Flatness is defined as the difference between the maximum and minimum value of on resistance (R_{ON}) over the specified range of conditions.
6. Guaranteed by characterization, not production tested.

AC Electrical Characteristics

All typical value are $T_A=25^\circ\text{C}$ unless otherwise specified.

Symbol	Parameter	Conditions	V_{CC} (V)	$T_A=+25^\circ\text{C}$			$T_A=-40$ to $+85^\circ\text{C}$		Unit	Figure
				Min.	Typ.	Max.	Min.	Max.		
t_{ON}	Turn-On Time FSA2269	nB0 or nB1=1.5 V, $R_L=50\ \Omega$, $C_L=35\ \text{pF}$	3.60 to 4.50			55	15	60	ns	Figure 10 Figure 11
			2.70 to 3.60			60	15	65		
			2.30 to 2.70			100	15	110		
			1.65 to 1.95		70					
	Turn-On Time FSA2269UCX	nB0 or nB1=1.5 V, $R_L=50\ \Omega$, $C_L=35\ \text{pF}$	3.60 to 4.50			105	15	110	ns	Figure 10 Figure 11
			2.70 to 3.60			115	15	150		
			2.30 to 2.70			180	15	185		
			1.65 to 1.95		110					
	Turn-On Time FSA2269TS	nB0 or nB1=1.5 V, $R_L=50\ \Omega$, $C_L=35\ \text{pF}$	3.60 to 4.50			3.5	0.5	4.0	μs	Figure 10 Figure 11
			2.70 to 3.60			4.5	0.5	5.0		
			2.30 to 2.70			6.0	0.5	7.0		
			1.65 to 1.95		8.0					
t_{OFF}	Turn-Off Time FSA2269	nB0 or nB1=1.5 V, $R_L=50\ \Omega$, $C_L=35\ \text{pF}$	3.60 to 4.50			50	5	55	ns	Figure 10 Figure 11
			2.70 to 3.60			55	5	60		
			2.30 to 2.70			60	5	65		
			1.65 to 1.95		40					
	Turn-Off Time FSA2269UCX	nB0 or nB1=1.5 V, $R_L=50\ \Omega$, $C_L=35\ \text{pF}$	3.60 to 4.50			100	5	105	ns	Figure 10 Figure 11
			2.70 to 3.60			110	5	115		
			2.30 to 2.70			120	5	125		
			1.65 to 1.95		80					
	Turn-Off Time FSA2269TS	nB0 or nB1=1.5 V, $R_L=50\ \Omega$, $C_L=35\ \text{pF}$	3.60 to 4.50			45	5	50	ns	Figure 10 Figure 11
			2.70 to 3.60			50	5	55		
			2.30 to 2.70			55	5	60		
			1.65 to 1.95		50					
t_{BBM}	Break-Before- Make Time FSA2269 ⁽⁷⁾	nB0 or nB1=1.5 V, $R_L=50\ \Omega$, $C_L=35\ \text{pF}$	3.60 to 4.50		3		1	ns	Figure 12	
			2.70 to 3.60		5		2			
			2.30 to 2.70		10		2			
			1.65 to 1.95		5		2			
t_{BBM}	Break-Before- Make Time FSA2269UCX ⁽⁷⁾	nB0 or nB1=1.5 V, $R_L=50\ \Omega$, $C_L=35\ \text{pF}$	3.60 to 4.50		9.5		5.5	ns	Figure 12	
			2.70 to 3.60		17.0		15.0			
			2.30 to 2.70		22.0		20.0			
			1.65 to 1.95		46.0		41.0			
t_{BBM}	Break-Before- Make Time FSA2269TS ⁽⁷⁾	nB0 or nB1=1.5 V, $R_L=50\ \Omega$, $C_L=35\ \text{pF}$	3.60 to 4.50		1.5		1.0	μs	Figure 12	
			2.70 to 3.60		3.0		1.5			
			2.30 to 2.70		4.0		2.5			
			1.65 to 1.95		5.0		3.0			

Continued on the following page...

AC Electrical Characteristics (Continued)

All typical values are $T_A=25^\circ\text{C}$ unless otherwise specified.

Symbol	Parameter	Conditions	V_{CC} (V)	$T_A=+25^\circ\text{C}$			$T_A=-40$ to $+85^\circ\text{C}$		Unit	Figure
				Min.	Typ.	Max.	Min.	Max.		
Q	Charge Injection	$C_L=1.0$ nF, $V_S=0$ V, $R_S=0$ Ω	1.65 to 4.50		25				pC	Figure 16
OIRR	Off Isolation	$f=100$ kHz, $R_L=50$ Ω, $C_L=0$ pF	1.65 to 4.50		-70				dB	Figure 14
Xtalk	Crosstalk	$f=100$ kHz, $R_L=50$ Ω, $C_L=0$ pF	1.65 to 4.50		-70				dB	Figure 15
BW	-3db Bandwidth	$R_L=50$ Ω, $C_L=0$ pF	1.65 to 4.50		>50				MHz	Figure 13
THD	Total Harmonic Distortion	$f=20$ Hz to 20 kHz, $R_L=32$ Ω, $V_{IN}=2$ V _{PP} $V_{BIAS}=0$ V	1.65 to 4.50		.06				%	Figure 19

Notes:

- Guaranteed by characterization, not production tested.

Capacitance

Symbol	Parameter	Conditions	V_{CC} (V)	$T_A=+25^\circ\text{C}$			Unit	Figure
				Min.	Typ.	Max.		
C_{IN}	Control Pin Input Capacitance	$f=1$ MHz	0		2.5		pF	Figure 17
C_{OFF}	B Port Off Capacitance	$f=1$ MHz	3.3		30		pF	Figure 17
C_{ON}	A Port On Capacitance	$f=1$ MHz	3.3		120		pF	Figure 18

Test Diagrams

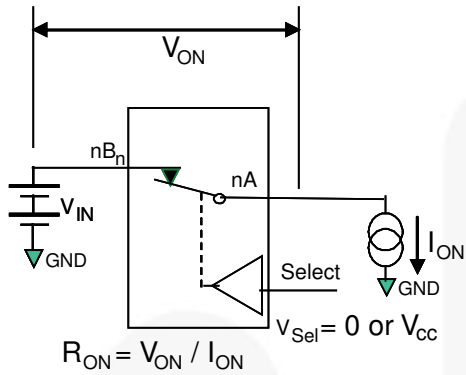

Figure 7. On Resistance

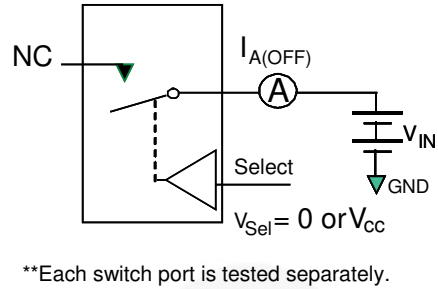

Figure 8. Off Leakage

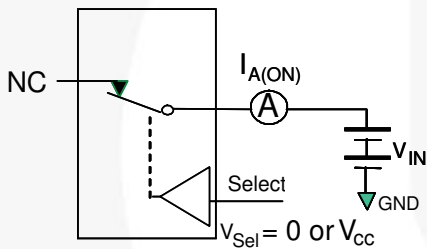

Figure 9. On Leakage

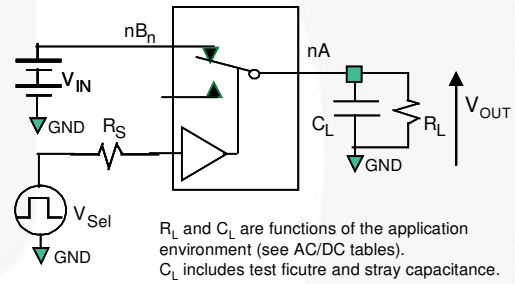

Figure 10. Test Circuit Load

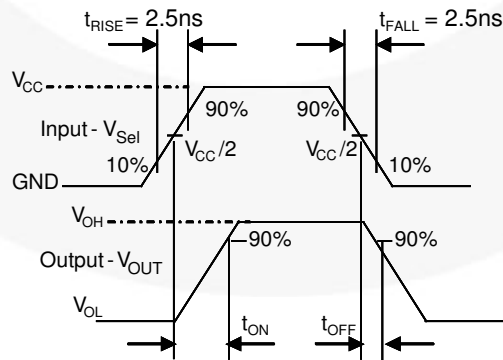

Figure 11. Turn-On / Turn-Off Waveforms

Test Diagrams (Continued)

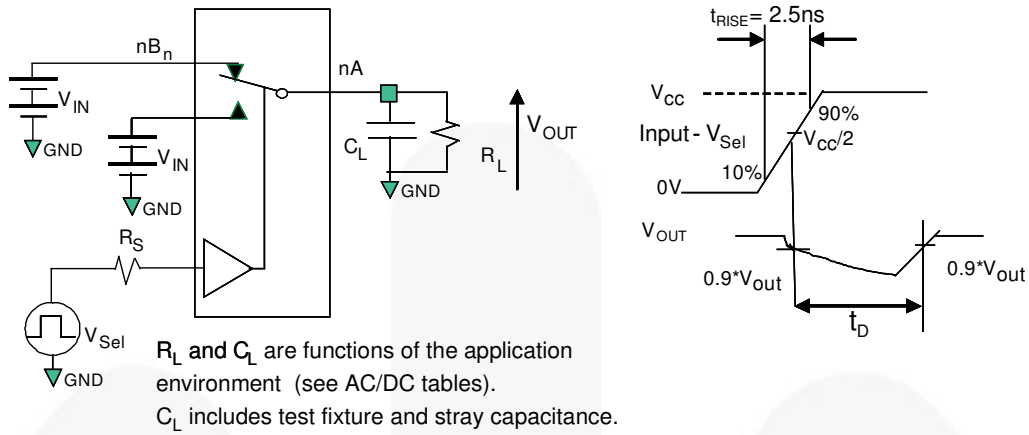

Figure 12. Break-Before-Make Interval Timing

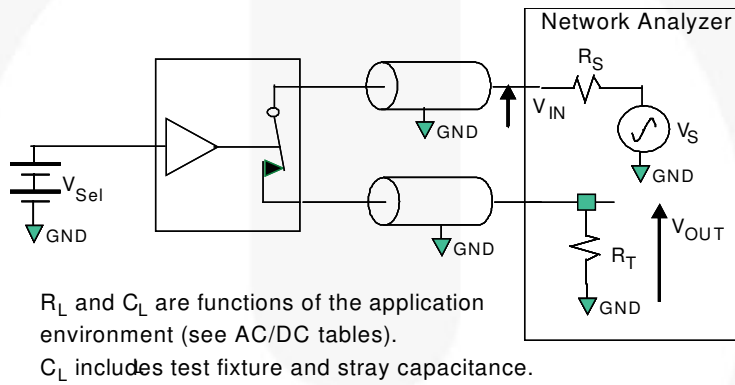

Figure 13. Bandwidth

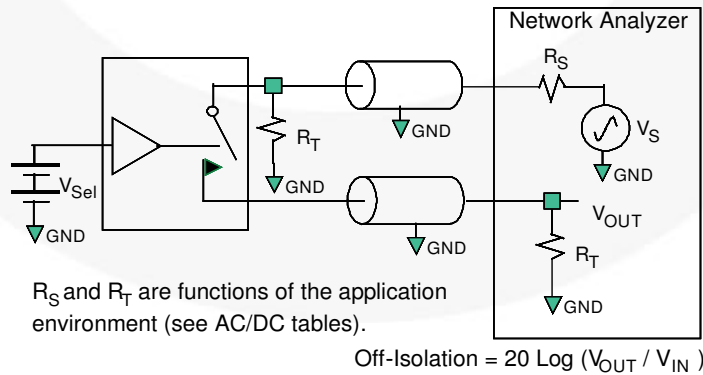

Figure 14. Channel Off Isolation

Test Diagrams (Continued)

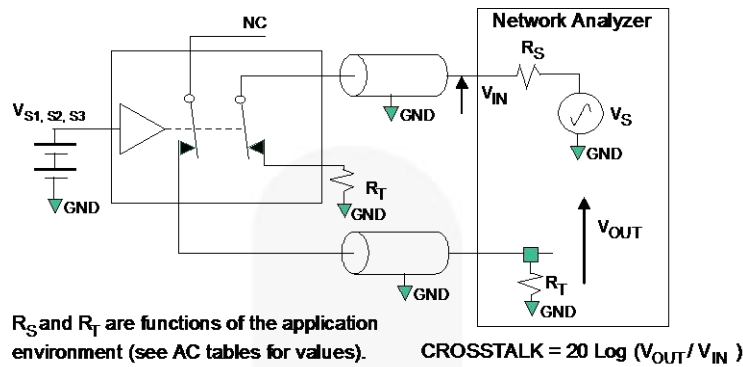

Figure 15. Adjacent Channel Crosstalk

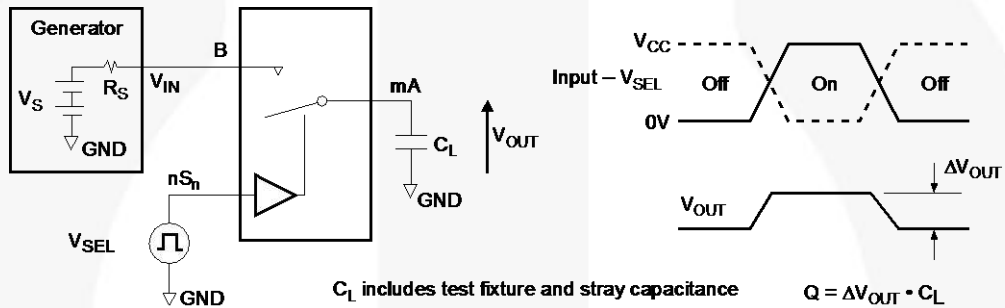

Figure 16. Charge Injection Test

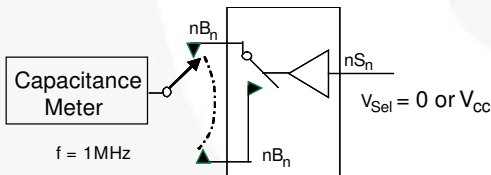

Figure 17. Channel Off Capacitance

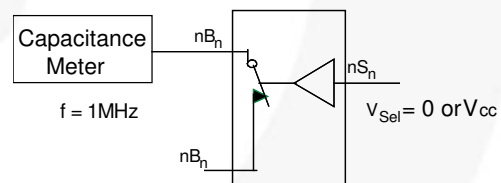

Figure 18. Channel On Capacitance

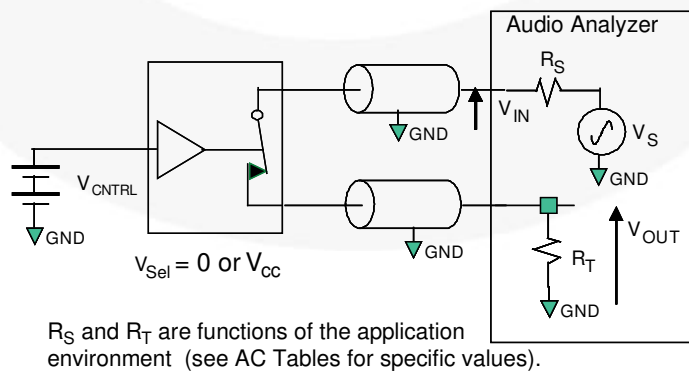

Figure 19. Total Harmonic Distortion

Physical Dimensions

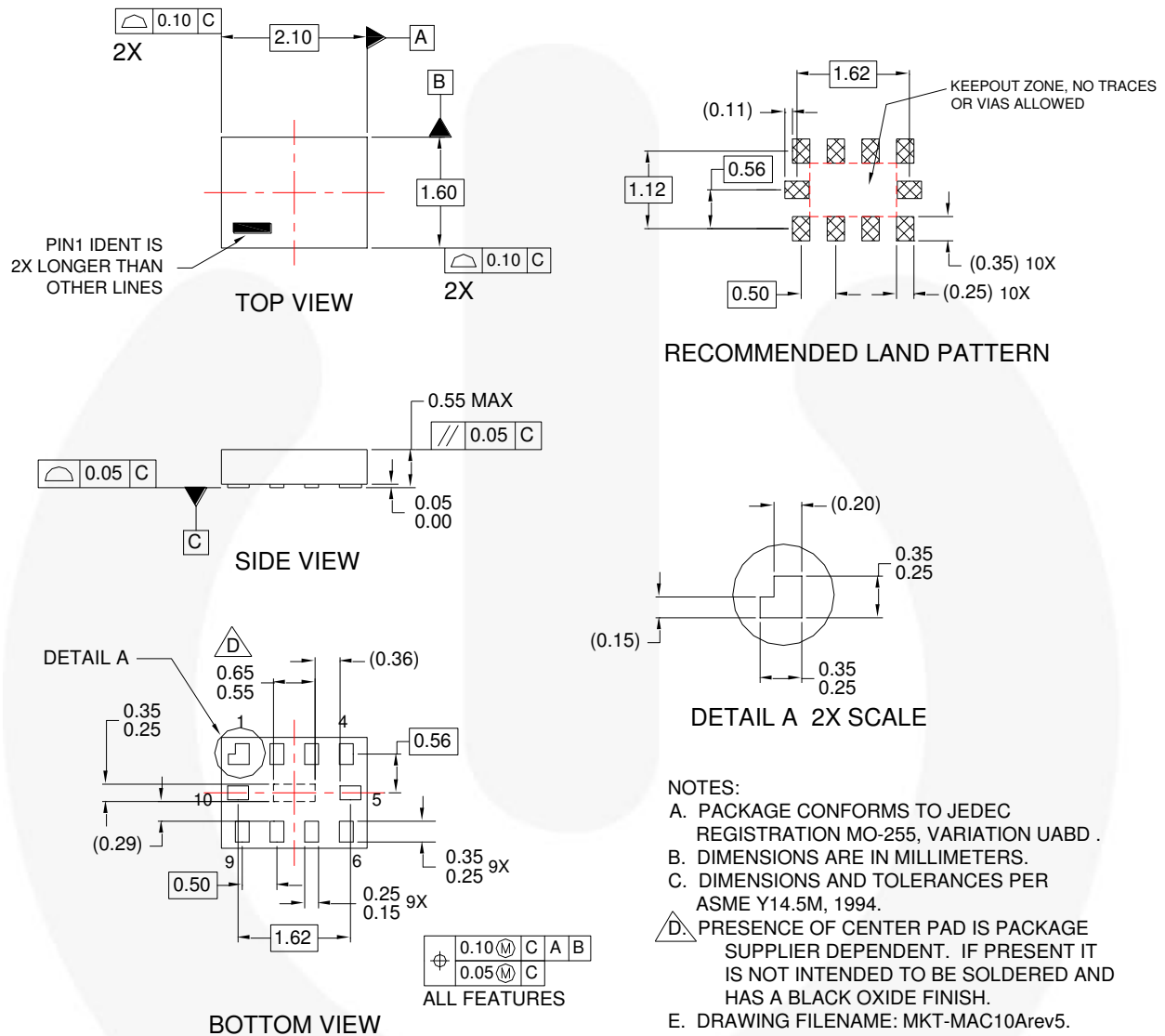

Figure 20. 10-Lead MicroPak™

Package drawings are provided as a service to customers considering Fairchild components. Drawings may change in any manner without notice. Please note the revision and/or date on the drawing and contact a Fairchild Semiconductor representative to verify or obtain the most recent revision. Package specifications do not expand the terms of Fairchild's worldwide terms and conditions, specifically the warranty therein, which covers Fairchild products.

Always visit Fairchild Semiconductor's online packaging area for the most recent package drawings:

<http://www.fairchildsemi.com/packaging/>.

Physical Dimensions (Continued)

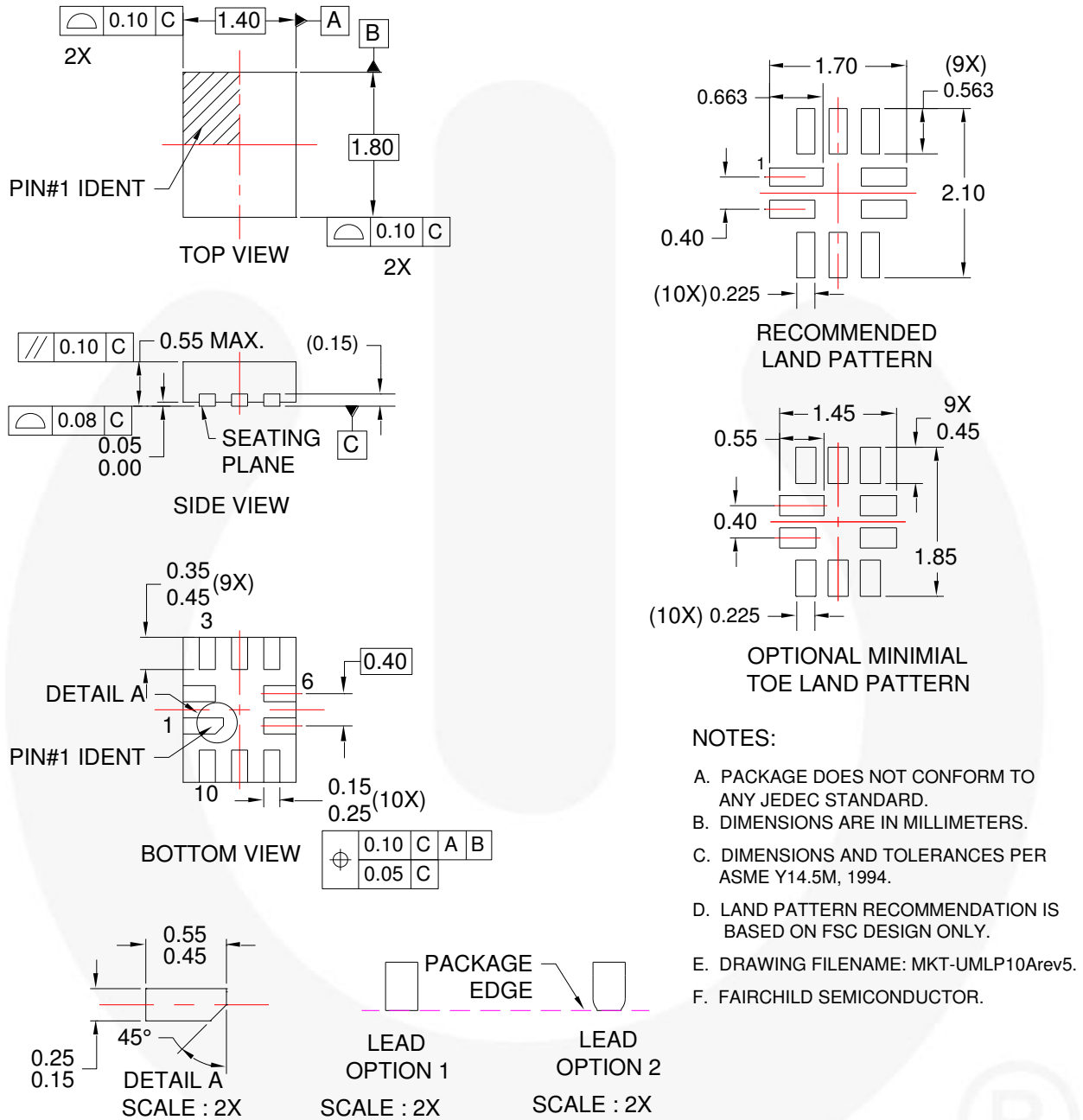
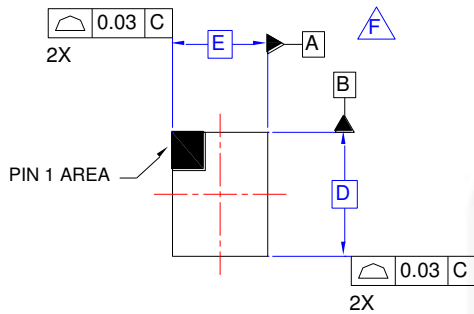

Figure 21. 10-Lead, Quad Ultrathin Molded Leadless Package (UMLP)

Package drawings are provided as a service to customers considering Fairchild components. Drawings may change in any manner without notice. Please note the revision and/or date on the drawing and contact a Fairchild Semiconductor representative to verify or obtain the most recent revision. Package specifications do not expand the terms of Fairchild's worldwide terms and conditions, specifically the warranty therein, which covers Fairchild products.

Always visit Fairchild Semiconductor's online packaging area for the most recent package drawings:
<http://www.fairchildsemi.com/packaging/>.

Physical Dimensions (Continued)



TOP VIEW

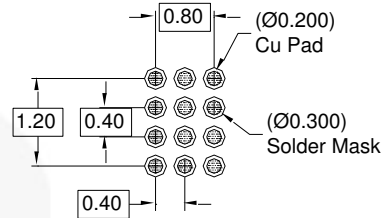

RECOMMENDED LAND PATTERN
(NSMD PAD TYPE)

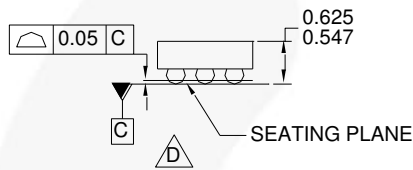

SIDE VIEWS

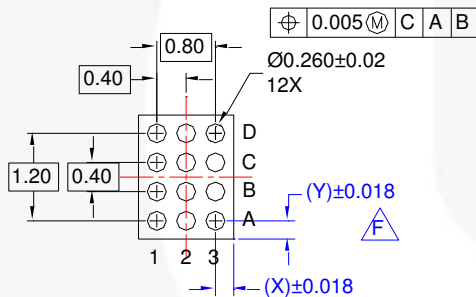
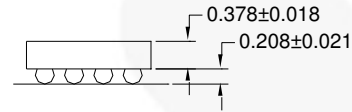

BOTTOM VIEW

NOTES:

- A. NO JEDEC REGISTRATION APPLIES.
- B. DIMENSIONS ARE IN MILLIMETERS.
- C. DIMENSIONS AND TOLERANCES PER ASME Y14.5M, 1994.
- D. DATUM C IS DEFINED BY THE SPHERICAL CROWNS OF THE BALLS.
- E. PACKAGE NOMINAL HEIGHT IS 586 MICRONS ±39 MICRONS (547-625 MICRONS).
- F. FOR DIMENSIONS D, E, X, AND Y SEE PRODUCT DATASHEET.
- G. DRAWING FILENAME: MKT-UC012ACrev1.

Product-Specific Dimensions

Product	D	E	X	Y
FSA2269UCX	1.560 mm	1.160 mm	0.180 mm	0.180 mm

Figure 22. 12-Ball, Wafer Level Chip-Scale Package (WLCSPP)

Package drawings are provided as a service to customers considering Fairchild components. Drawings may change in any manner without notice. Please note the revision and/or date on the drawing and contact a Fairchild Semiconductor representative to verify or obtain the most recent revision. Package specifications do not expand the terms of Fairchild's worldwide terms and conditions, specifically the warranty therein, which covers Fairchild products.

Always visit Fairchild Semiconductor's online packaging area for the most recent package drawings:
<http://www.fairchildsemi.com/packaging/>



TRADEMARKS

The following includes registered and unregistered trademarks and service marks, owned by Fairchild Semiconductor and/or its global subsidiaries, and is not intended to be an exhaustive list of all such trademarks.

2Cool™	FPST™		Sync-Lock™
AccuPower™	F-PFST™	PowerTrench®	 SYSTEM GENERAL®
AX-CAP®	FRFET®	PowerXS™	TinyBoost™
BitSIC™	Global Power Resource™	Programmable Active Droop™	TinyBuck™
Build it Now™	GreenBridge™	QFET®	TinyCalc™
CorePLUS™	Green FPS™	QST™	TinyLogic®
CorePOWER™	Green FPS™ e-Series™	Quiet Series™	TINYOPTO™
CROSSVOLT™	Gmax™	RapidConfigure™	TinyPower™
CTL™	GTO™	 ™	TinyPWM™
Current Transfer Logic™	IntelliMAX™	Saving our world, 1mW/WKw at a time™	TinyWire™
DEUXPEED®	ISOPLANAR™	SignalWise™	TranSIC™
Dual Cool™	Making Small Speakers Sound Louder and Better™	SmartMax™	TriFault Detect™
EcoSPARK®	MegaBuck™	SMART START™	TRUECURRENT®
EfficientMax™	MICROCOUPLER™	Solutions for Your Success™	μSerDes™
ESBC™	MicroFET™	SPM®	 SerDes™
 Fairchild®	MicroPak™	STEALTH™	UHC®
Fairchild Semiconductor®	MicroPak2™	SuperFET®	Ultra FRFET™
FACT Quiet Series™	MillerDrive™	SuperSOT™-3	UniFET™
FACT®	MotionMax™	SuperSOT™-6	VCX™
FAST®	mWSaver™	SuperSOT™-8	VisualMax™
FastvCore™	OptoHiT™	SupreMOS®	VoltagePlus™
FETBench™	OPTOLOGIC®	SyncFET™	XS™
	OPTOPLANAR®		

* Trademarks of System General Corporation, used under license by Fairchild Semiconductor.

DISCLAIMER

FAIRCHILD SEMICONDUCTOR RESERVES THE RIGHT TO MAKE CHANGES WITHOUT FURTHER NOTICE TO ANY PRODUCTS HEREIN TO IMPROVE RELIABILITY, FUNCTION, OR DESIGN. FAIRCHILD DOES NOT ASSUME ANY LIABILITY ARISING OUT OF THE APPLICATION OR USE OF ANY PRODUCT OR CIRCUIT DESCRIBED HEREIN, NEITHER DOES IT CONVEY ANY LICENSE UNDER ITS PATENT RIGHTS, NOR THE RIGHTS OF OTHERS. THESE SPECIFICATIONS DO NOT EXPAND THE TERMS OF FAIRCHILD'S WORLDWIDE TERMS AND CONDITIONS, SPECIFICALLY THE WARRANTY THEREIN, WHICH COVERS THESE PRODUCTS.

LIFE SUPPORT POLICY

FAIRCHILD'S PRODUCTS ARE NOT AUTHORIZED FOR USE AS CRITICAL COMPONENTS IN LIFE SUPPORT DEVICES OR SYSTEMS WITHOUT THE EXPRESS WRITTEN APPROVAL OF FAIRCHILD SEMICONDUCTOR CORPORATION.

As used herein:

1. Life support devices or systems are devices or systems which, (a) are intended for surgical implant into the body or (b) support or sustain life, and (c) whose failure to perform when properly used in accordance with instructions for use provided in the labeling, can be reasonably expected to result in a significant injury of the user.
2. A critical component in any component of a life support device, or system whose failure to perform can be reasonably expected to cause the failure of the life support device or system, or to affect its safety or effectiveness.

ANTI-COUNTERFEITING POLICY

Fairchild Semiconductor Corporation's Anti-Counterfeiting Policy. Fairchild's Anti-Counterfeiting Policy is also stated on our external website, www.fairchildsemi.com, under Sales Support.

Counterfeiting of semiconductor parts is a growing problem in the industry. All manufacturers of semiconductor products are experiencing counterfeiting of their parts. Customers who inadvertently purchase counterfeit parts experience many problems such as loss of brand reputation, substandard performance, failed applications, and increased cost of production and manufacturing delays. Fairchild is taking strong measures to protect ourselves and our customers from the proliferation of counterfeit parts. Fairchild strongly encourages customers to purchase Fairchild parts either directly from Fairchild or from Authorized Fairchild Distributors who are listed by country on our web page cited above. Products customers buy either from Fairchild directly or from Authorized Fairchild Distributors are genuine parts, have full traceability, meet Fairchild's quality standards for handling and storage and provide access to Fairchild's full range of up-to-date technical and product information. Fairchild and our Authorized Distributors will stand behind all warranties and will appropriately address any warranty issues that may arise. Fairchild will not provide any warranty coverage or other assistance for parts bought from Unauthorized Sources. Fairchild is committed to combat this global problem and encourage our customers to do their part in stopping this practice by buying direct or from authorized distributors.

PRODUCT STATUS DEFINITIONS

Definition of Terms

Datasheet Identification	Product Status	Definition
Advance Information	Formative / In Design	Datasheet contains the design specifications for product development. Specifications may change in any manner without notice.
Preliminary	First Production	Datasheet contains preliminary data; supplementary data will be published at a later date. Fairchild Semiconductor reserves the right to make changes at any time without notice to improve design.
No Identification Needed	Full Production	Datasheet contains final specifications. Fairchild Semiconductor reserves the right to make changes at any time without notice to improve the design.
Obsolete	Not In Production	Datasheet contains specifications on a product that is discontinued by Fairchild Semiconductor. The datasheet is for reference information only.

Rev. I64

ON Semiconductor and  are trademarks of Semiconductor Components Industries, LLC dba ON Semiconductor or its subsidiaries in the United States and/or other countries. ON Semiconductor owns the rights to a number of patents, trademarks, copyrights, trade secrets, and other intellectual property. A listing of ON Semiconductor's product/patent coverage may be accessed at www.onsemi.com/site/pdf/Patent-Marking.pdf. ON Semiconductor reserves the right to make changes without further notice to any products herein. ON Semiconductor makes no warranty, representation or guarantee regarding the suitability of its products for any particular purpose, nor does ON Semiconductor assume any liability arising out of the application or use of any product or circuit, and specifically disclaims any and all liability, including without limitation special, consequential or incidental damages. Buyer is responsible for its products and applications using ON Semiconductor products, including compliance with all laws, regulations and safety requirements or standards, regardless of any support or applications information provided by ON Semiconductor. "Typical" parameters which may be provided in ON Semiconductor data sheets and/or specifications can and do vary in different applications and actual performance may vary over time. All operating parameters, including "Typicals" must be validated for each customer application by customer's technical experts. ON Semiconductor does not convey any license under its patent rights nor the rights of others. ON Semiconductor products are not designed, intended, or authorized for use as a critical component in life support systems or any FDA Class 3 medical devices or medical devices with a same or similar classification in a foreign jurisdiction or any devices intended for implantation in the human body. Should Buyer purchase or use ON Semiconductor products for any such unintended or unauthorized application, Buyer shall indemnify and hold ON Semiconductor and its officers, employees, subsidiaries, affiliates, and distributors harmless against all claims, costs, damages, and expenses, and reasonable attorney fees arising out of, directly or indirectly, any claim of personal injury or death associated with such unintended or unauthorized use, even if such claim alleges that ON Semiconductor was negligent regarding the design or manufacture of the part. ON Semiconductor is an Equal Opportunity/Affirmative Action Employer. This literature is subject to all applicable copyright laws and is not for resale in any manner.

PUBLICATION ORDERING INFORMATION

LITERATURE FULFILLMENT:

Literature Distribution Center for ON Semiconductor
19521 E. 32nd Pkwy, Aurora, Colorado 80011 USA
Phone: 303-675-2175 or 800-344-3860 Toll Free USA/Canada
Fax: 303-675-2176 or 800-344-3867 Toll Free USA/Canada
Email: orderlit@onsemi.com

N. American Technical Support: 800-282-9855 Toll Free
USA/Canada
Europe, Middle East and Africa Technical Support:
Phone: 421 33 790 2910
Japan Customer Focus Center
Phone: 81-3-5817-1050

ON Semiconductor Website: www.onsemi.com
Order Literature: <http://www.onsemi.com/orderlit>
For additional information, please contact your local
Sales Representative