



**RAD HARD POSITIVE,
0.9A, LDO, SINGLE RESISTOR
ADJ VOLTAGE REGULATOR**

5979RH

FEATURES:

- Manufactured using  Space Qualified RH3080 Die
- Total Dose Hardened to 300 Krads(Si) (Method 1019.7 Condition A)
- Low Dropout to 300mV (VIN - VOUT, with Seperate CTL Supply)
- Output Adjustable to Zero Volts
- Internal Short Circuit Current Limit
- Output Voltage is Adjustable with 1 External Resistor
- Output Current Capability to 0.9 Amps
- Internal Thermal Overload Protection
- Outputs may be Paralleled for Higher Current
- Available in 3 Lead Form Options with Ceramic Seals: Straight, Up and Down (TO257)
- Contact MSK for MIL-PRF-38534 Qualification Status

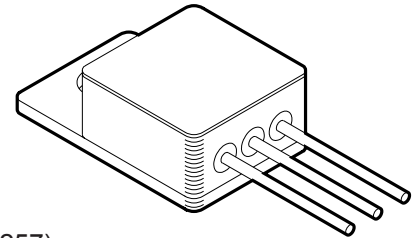

DESCRIPTION:

The MSK5979RH offers low dropout down to 300mV and an output voltage range down to zero volts while offering radiation tolerance for space applications. This, combined with the low θ_{JC} , allows increased output current while providing exceptional device efficiency. Because of the increased efficiency, a small hermetic 3 pin package can be used providing maximum performance while occupying minimal board space. Output voltage is selected by the user through the use of 1 external resistor. Additionally, the regulator offers internal short circuit current and thermal limiting, which allows circuit protection and eliminates the need for external components and excessive derating.

EQUIVALENT SCHEMATIC

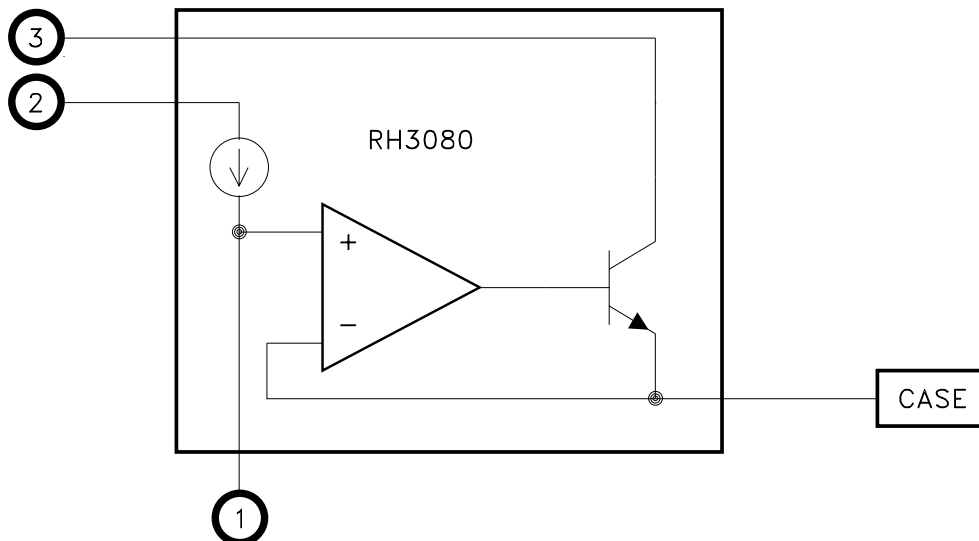

TYPICAL APPLICATIONS

- High Efficiency Linear Regulators
- Constant Voltage/Current Regulators
- Space System Power Supplies
- Switching Power Supply Post Regulators
- Very low Voltage Power Supplies

PIN-OUT INFORMATION

- 1 SET
 - 2 CTL
 - 3 VIN
- CASE VOUT

ABSOLUTE MAXIMUM RATINGS ^⑨

V _{IN}	Input Voltage ^⑦	+40V,-0.3V	T _{ST}	Storage Temperature Range.....	-65°C to +150°C
V _{CTL}	Control Voltage ^⑦	+40V,-0.3V	T _{LD}	Lead Temperature Range (10 Seconds).....	300°C
P _D	Power Dissipation.....	Internally Limited	T _C	Case Operating Temperature MSK5979RH.....	-40°C to +85°C
I _{OUT}	Output Current ^⑧	0.9A		MSK5979K/H	-55°C to +125°C
T _J	Junction Temperature	+150°C		ESD Rating.....	Class 2

ELECTRICAL SPECIFICATIONS

Parameter	Test Conditions ^① ^⑩	Group A Subgroup	MSK5979K/H			MSK5979RH			Units
			Min.	Typ.	Max.	Min.	Typ.	Max.	
Set Pin Current (I _{set})	V _{CTL} = V _{IN} = 3.0V V _{OUT} = 1.0V 1mA ≤ I _{LOAD} ≤ 0.9A	1	9.80	10.0	10.20	9.80	10.0	10.20	µA
		2,3	9.80	-	10.30	-	-	-	µA
		1	9.7	-	10.5	9.7	-	10.5	µA
Output Offset Voltage (V _{os})	V _{CTL} = V _{IN} = 3.0V V _{OUT} = 1.0V I _{LOAD} = 1mA	1	-5	0	5	-5	0	5	mV
		2,3	-6	-	6	-	-	-	mV
Load Regulation (ΔV _{os}) (ΔI _{set}) ^②	V _{CTL} = V _{IN} = 3.0V V _{OUT} = 1.0V 1mA ≤ I _{LOAD} ≤ 0.9A	1	-2.5	0.7	2.5	-2.5	1.0	2.5	mV
		2,3	-2.5	-	2.5	-	-	-	mV
		1	-	-0.1	-	-	-0.1	-	nA
Line Regulation (Δ I _{set}) (Δ V _{os}) ^②	3V ≤ V _{IN} = V _{CTL} ≤ 25V V _{OUT} = 1.0V I _{LOAD} = 1mA	1	-0.5	0.1	0.5	-0.5	0.1	0.5	nA/V
		2,3	-1.0	-	1.0	-	-	-	nA/V
		1	-	0.003	-	-	0.003	-	mV/V
		1	-0.7	-	0.7	-0.7	-	0.7	nA/V
VIN Dropout Voltage	V _{OUT} = 1.0V I _{LOAD} = 0.9A V _{CTL} = 3.0V	1	-	320	500	-	320	500	mV
		2,3	-	-	600	-	-	-	mV
V _{control} Dropout Voltage	V _{OUT} = 1.0V I _{LOAD} = 0.9A V _{IN} = 3.0V	1	-	1.4	1.6	-	1.4	1.6	V
		2,3	-	-	1.7	-	-	-	V
Control Pin Current	V _{IN} = 2.0V V _{OUT} = 1.0V V _{CTL} = 3.0V I _{LOAD} = 100mA	1	-	4.3	6.6	-	4.3	6.6	mA
		2,3	-	-	6.6	-	-	-	mA
Current Limit ^⑧	V _{CTL} = V _{IN} = 5.0V V _{OUT} = 1.0V	1	0.9	1.1	-	0.9	1.1	-	A
		2,3	0.9	-	-	-	-	-	A
Minimum Load Current ^⑥	V _{CTL} = V _{IN} = 25V	-	-	-	1	-	-	1	mA
Ripple Rejection ^②	F = 120Hz ΔV _{IN} = 0.5V _{pp}	-	-	75	-	-	75	-	dB
Thermal Resistance ^②	Junction to Case @125°C	-	-	4.4	5.0	-	4.4	5.0	°C/W

NOTES:

- ① Output is decoupled to ground using A 220µF tantalum low ESR capacitor in parallel with 3 pieces of 1.0µF and one 0.1µF ceramic capacitors unless otherwise specified. (See Figure 1)
- ② Guaranteed by design but not tested. Typical parameters are representative of actual device performance but are for reference only.
- ③ Industrial grade devices shall be tested to subgroup 1 unless otherwise specified.
- ④ Military grade ("H" suffix) and space grade ("K" suffix) devices shall be 100% tested to subgroups 1,2 and 3.
- ⑤ Subgroup 1 TA=TC=+25°C
Subgroup 2 TA=TC=+125°C
Subgroup 3 TA=TC=-55°C
- ⑥ Minimum load current verified while testing line regulation.
- ⑦ Voltage is measured with respect to V_{OUT}.
- ⑧ Reference the current limit typical performance curve for input to output voltage differential verses output current capabilities.
- ⑨ Continuous operation at or above absolute maximum ratings may adversely effect the device performance and/or life cycle.
- ⑩ Pre and Post irradiation limits at 25°C, up to 300 Krads(Si) TID, are identical unless otherwise specified.

APPLICATION NOTES

OUTPUT VOLTAGE

A single resistor (Rset) from the SET pin to ground creates the reference voltage for the internal Error Amplifier. The MSK5979RH SET pin supplies a constant current of 10uA that develops the reference voltage. The output voltage is simply $R_{set} \times 10\mu A$. Since the output is internally driven by a unity-gain amplifier, an alternative to using Rset is to connect a high quality reference source to the SET pin. With a minimum load requirement of 1mA on the Output, the Output Voltage can be adjusted to near 0V. To bring the output voltage to 0V, the load must be connected to a slightly negative voltage supply to sink the 1mA minimum load current from a 0V output.

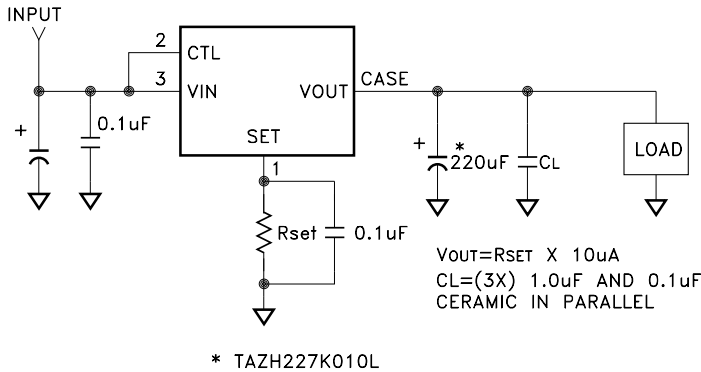

FIGURE 1

OUTPUT CAPACITANCE

For stability purposes, the MSK5979RH requires a minimum output capacitor of 10μF with an ESR of 0.5Ω or less. Tantalum or ceramic capacitors are recommended. A larger capacitance value will improve transient response for increased load current changes. Consideration must also be given to temperature characteristics of the capacitors used.

LOW DROPOUT OPERATION

Using separate VIN and Vcontrol power supplies allows for lower dropout and improved efficiency. Figure 2 shows the MSK5979RH output transistor collector is connected to the VIN pin. The regulator control circuitry is powered by the Vcontrol input. The dropout of the regulator is determined by the saturation voltage of the output transistor, typical 300mV at 0.9A load. The Vcontrol supply must supply the base drive current for the output transistor. The Vcontrol current minus the 10μA set current is supplied to the load. See the Typical Performance Characteristics curves for expected VIN dropout voltage, control pin dropout voltage and current requirements under various conditions. With separate supplies for VIN and Vcontrol, power dissipation is reduced and efficiency improves.

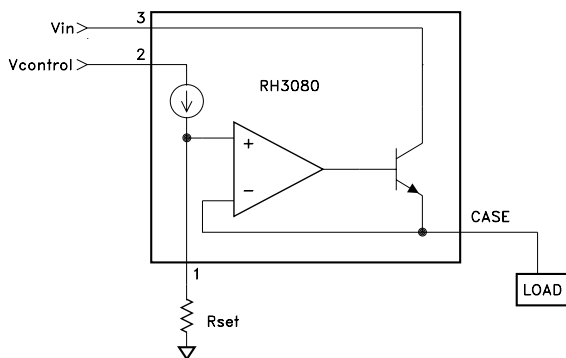

FIGURE 2

ADDITIONAL STABILITY

A capacitor placed in parallel with the SET pin resistor to ground, will improve the output transient response and filter noise in the system. To reduce output noise, typically less than 100pF is all that will be required. Capacitors up to 1μF can be used, however consideration must be given to the effect the time constant created will have on the startup time.

LOAD REGULATION

The MSK5979RH specified load regulation is Kelvin Sensed, therefore the parasitic resistance of the system must be considered to design an acceptable load regulation. The overall load regulation includes the specified MSK5979RH load regulation plus the parasitic resistance multiplied by the load current as shown in Figure 3. RSO is the series resistance of all conductors between the MSK5979RH output and the load. It will directly increase output load regulation error by a voltage drop of $\Delta I_o \times R_{so}$. RSS is the series resistance between the set pin and the load. RSS will have little effect on load regulation if the set pin trace is connected as close to the load as possible keeping the load return current on a separate trace as shown. RSR is the series resistance of all of the conductors between the load and the input power source return. RSR will not effect load regulation if the set pin is connected with a Kelvin Sense type connection as shown in Figure 3, but it will increase the effective dropout voltage by a factor of $I_O \times R_{SR}$. Keeping RSO and RSR as low as possible will ensure minimal voltage drops and wasted power.

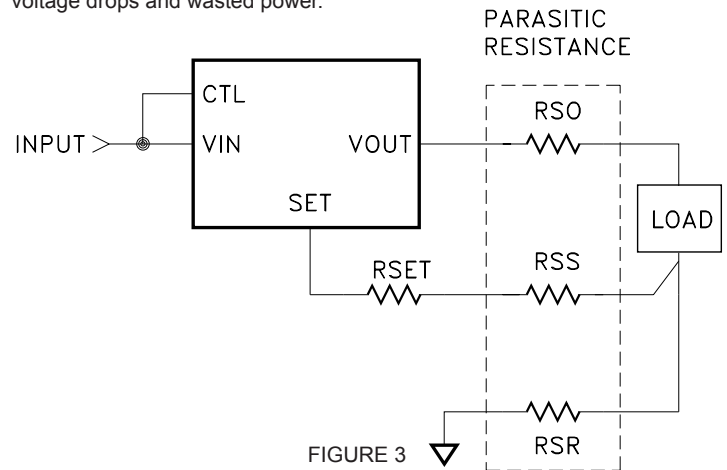

FIGURE 3

PARALLELING DEVICES

When currents greater than 0.9A are needed, the MSK5979RH's may be paralleled to multiply the current capacity. As shown in Figure 4, the Vin and SET pins must be tied together. The VOUT pins are connected to the load with consideration to the conductor resistance. The conductor resistance of each MSK5979RH VOUT connection to the load, must be equal to create equal load sharing. As little as 10mΩ ballast resistance typically ensures better than 80% equal sharing of load current at full load. Additional consideration must be given to the effect the additional VOUT conductor resistance has on load regulation; see paragraph titled "Load Regulation".

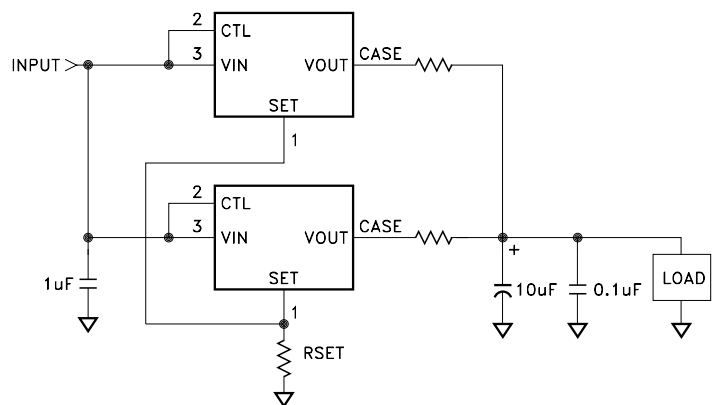

FIGURE 4

IMPROVING INITIAL ACCURACY AND REDUCING TEMPERATURE DRIFT

The initial output accuracy of the MSK5979RH due to set pin current tolerance and set point resistor accuracy can be reduced to 0.2% using the MSK109RH radiation hardened precision reference. Minimal drift of the MSK109RH from temperature extremes and irradiation ensure very tight regulation. The circuit can be configured to use the 2.5V reference to directly set the output at 2.5V or with a slight variation it can provide any output within the operating range of the MSK5979RH down to 0V output. Select R_s to maintain between 1mA and 10mA of current through the reference; see Figure 5 below. R_s may be tied to VIN or another power source. The optional trim resistor can be used to further trim out initial output and system error. Reference the MSK109RH data sheet for application circuits that provide stable output voltages across the full operating range of the MSK5979RH including down to 0V output and the operating characteristics of the MSK109RH.

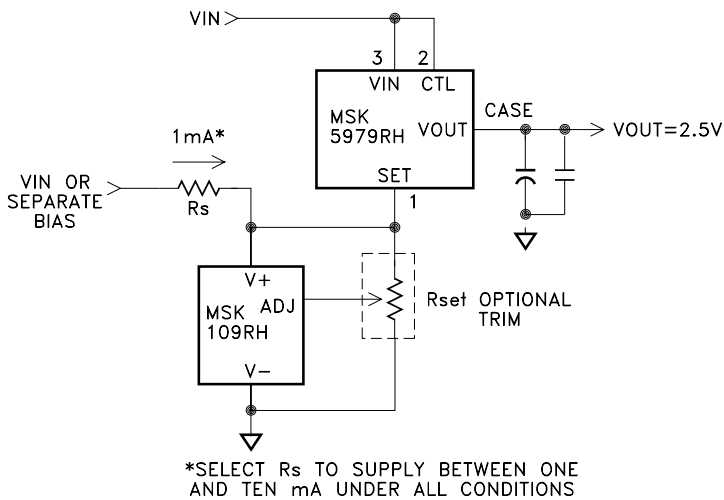

FIGURE 5

ADDING SHUTDOWN

The MSK5979RH can be easily shutdown by either reducing R_{set} to 0Ω or connecting a transistor from the set pin to ground. By connecting two transistors, as shown in Figure 6, a low current voltage source is all that is required to take the set pin to ground as well as pull the output voltage to ground. Q2 pulls the output voltage to ground when no load is present and only needs to sink 10mA. Use a low leakage switching diode between Vout and Set to avoid overstress during shutdown transitions.

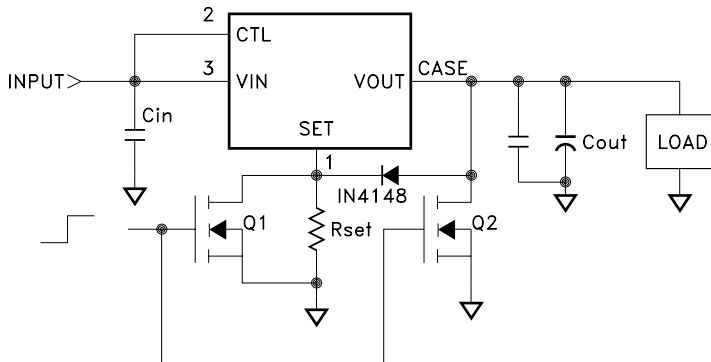

FIGURE 6

HEAT SINKING

To determine if a heat sink is required for your application and if so, what type, refer to the thermal model and governing equation below.

$$\text{Governing Equation: } T_j = P_d \times (R_{\theta jc} + R_{\theta cs} + R_{\theta sa}) + T_a$$

WHERE

- T_j = Junction Temperature
- P_d = Total Power Dissipation
- $R_{\theta jc}$ = Junction to Case Thermal Resistance
- $R_{\theta cs}$ = Case to Heat Sink Thermal Resistance
- $R_{\theta sa}$ = Heat Sink to Ambient Thermal Resistance
- T_c = Case Temperature
- T_a = Ambient Temperature
- T_s = Heat Sink Temperature

EXAMPLE:

This example demonstrates the thermal calculations for the TO-257 package with the regulator operating at one-half of its maximum rated output current.

Conditions for MSK5979RH:

$$V_{CTL}=V_{IN} = +3.0V; I_{out} = +0.45A \quad V_{OUT}=+1.0V$$

- 1.) Assume 45° heat spreading model.
- 2.) Find regulator power dissipation:

$$\begin{aligned} P_d &= (V_{IN} - V_{OUT})(I_{out}) \\ P_d &= (3-1)(0.45) \\ &= 0.9W \end{aligned}$$

- 3.) For conservative design, set $T_j = +125^\circ\text{C}$ Max.
- 4.) For this example, worst case $T_a = +90^\circ\text{C}$.
- 5.) $R_{\theta jc} = 5.0^\circ\text{C/W}$ from the Electrical Specification Table.
- 6.) $R_{\theta cs} = 0.15^\circ\text{C/W}$ for most thermal greases.
- 7.) Rearrange governing equation to solve for $R_{\theta sa}$:

$$\begin{aligned} R_{\theta sa} &= ((T_j - T_a)/P_d) - (R_{\theta jc}) - (R_{\theta cs}) \\ &= (125^\circ\text{C} - 90^\circ\text{C})/0.9W - 5.0^\circ\text{C/W} - 0.15^\circ\text{C/W} \\ &= 33.7^\circ\text{C/W} \end{aligned}$$

In this case the result is 33.7°C/W . Therefore, a heat sink with a thermal resistance of no more than 33.7°C/W must be used in this application to maintain regulator circuit junction temperature under 125°C .

TOTAL DOSE RADIATION TEST PERFORMANCE

Radiation performance curves for TID testing have been generated for all radiation testing performed by MS Kennedy. These curves show performance trends throughout the TID test process and can be located in the MSK5977RH radiation test report. The complete radiation test report is available in the RAD HARD PRODUCTS section on the MSK website.

ADDITIONAL APPLICATION INFORMATION

For additional applications information, please reference Linear Technology Corporation's® LT3080 and RH3080 data sheets.

DIE GLASSIVATION

For enhanced radiation tolerance the die has a glassivation thickness of 4KA and is not in accordance with MIL-PRF-38534.

TYPICAL PERFORMANCE CURVES

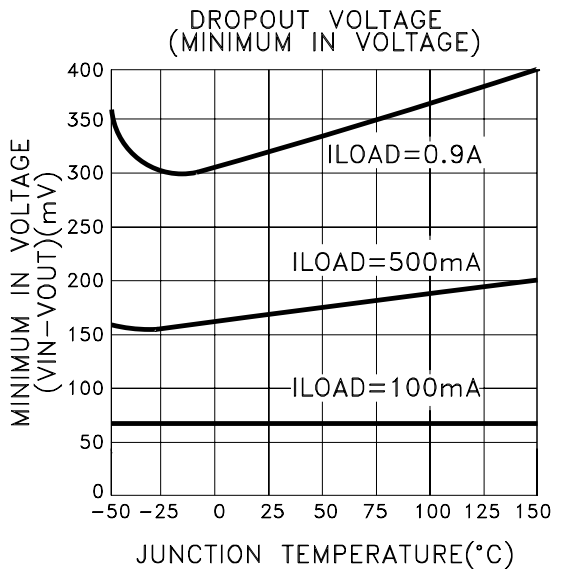
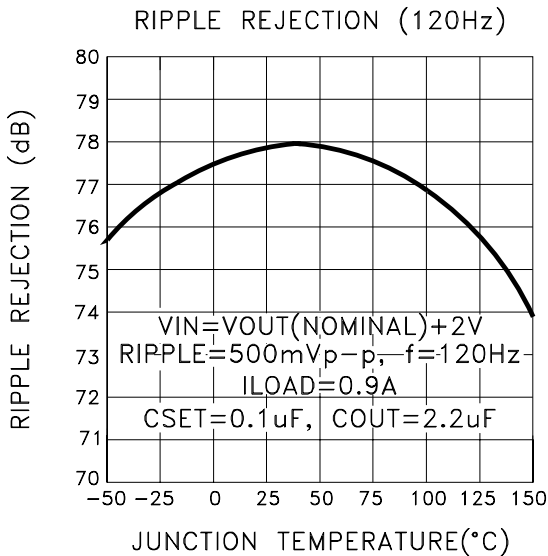
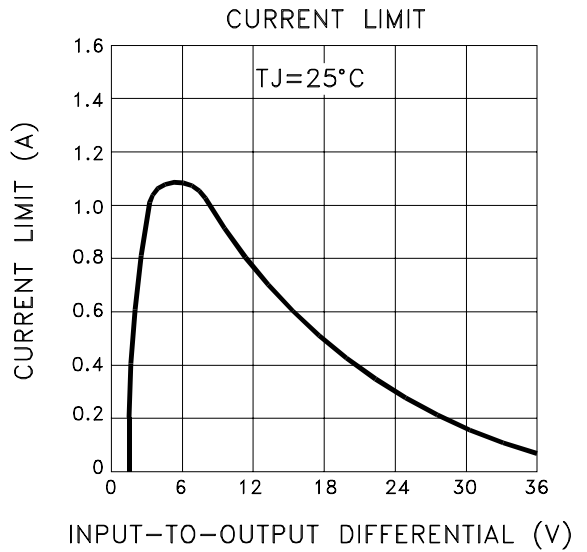
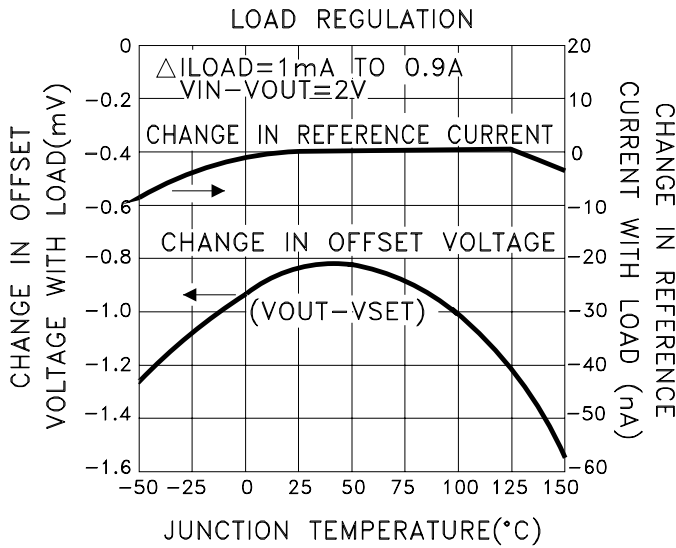
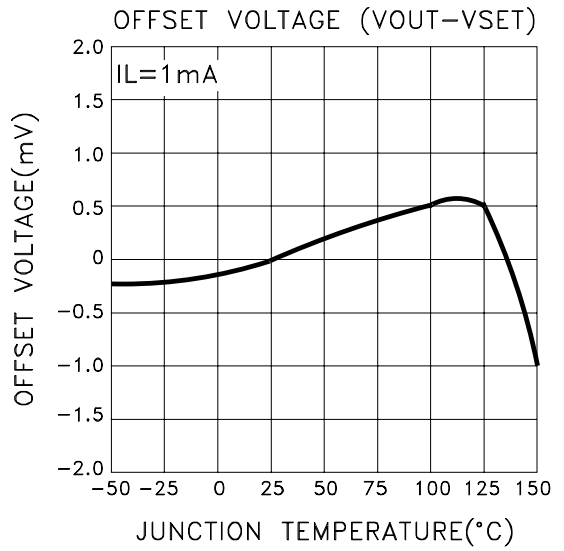
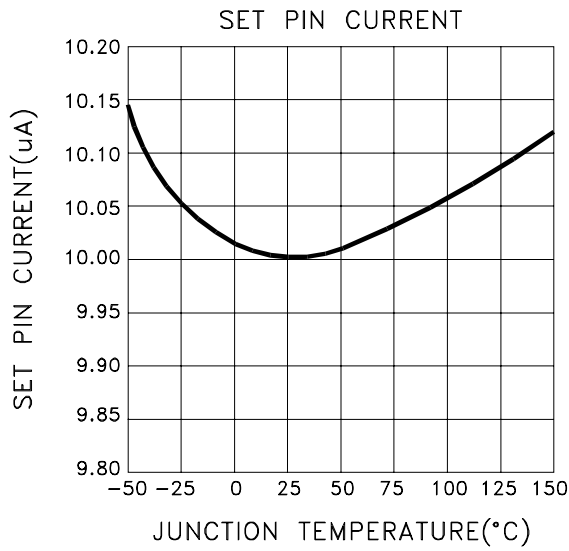

TYPICAL PERFORMANCE CURVES CONT'D

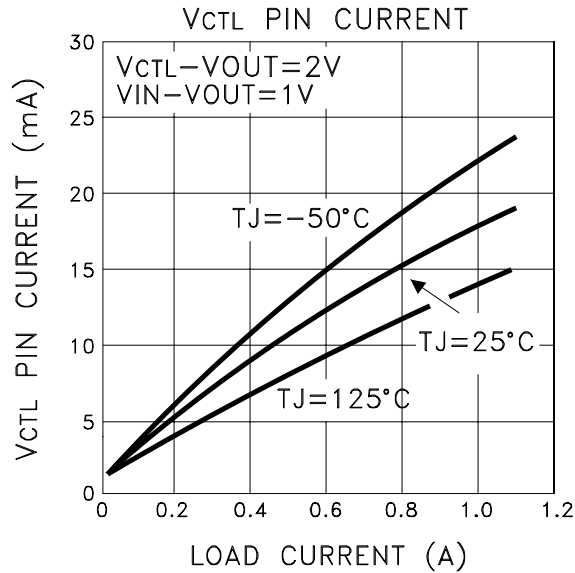
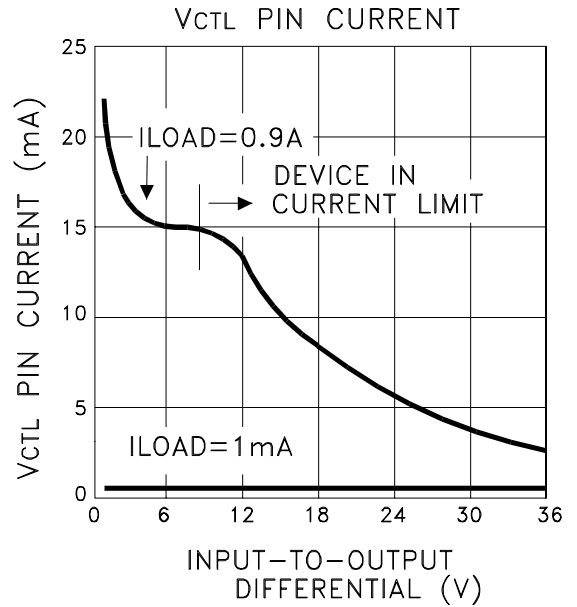
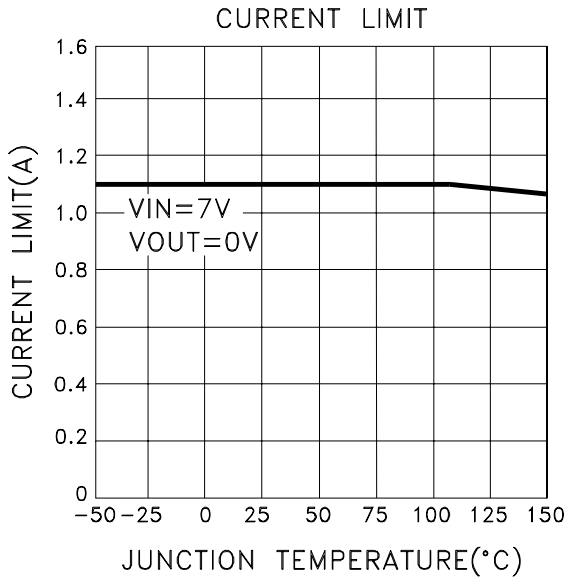
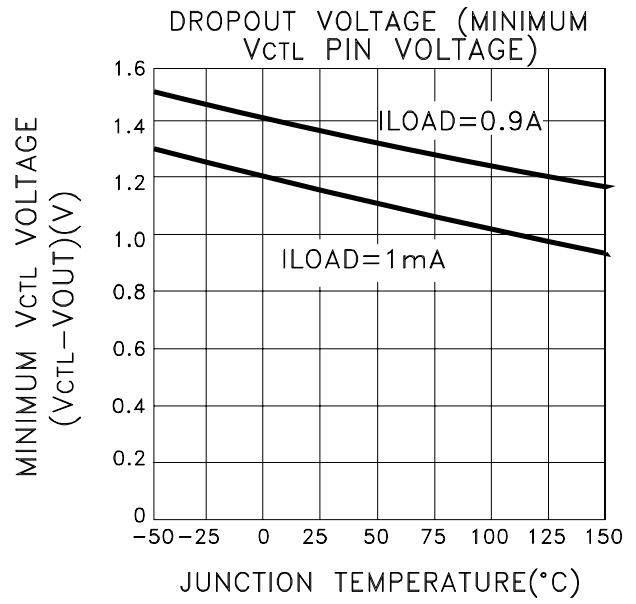
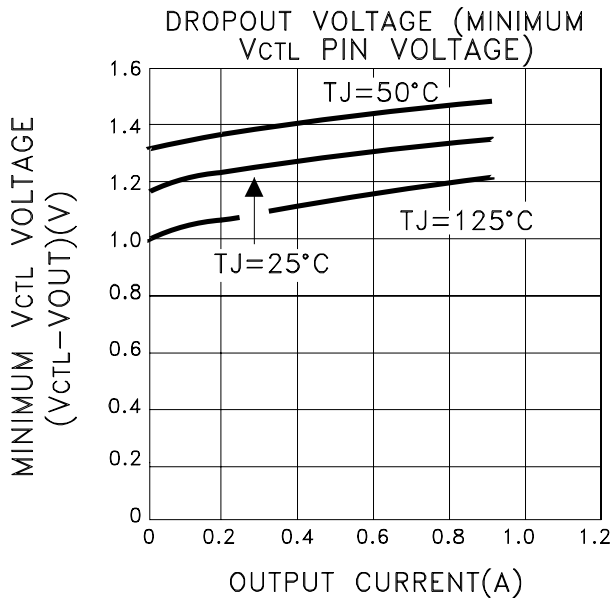

MECHANICAL SPECIFICATIONS

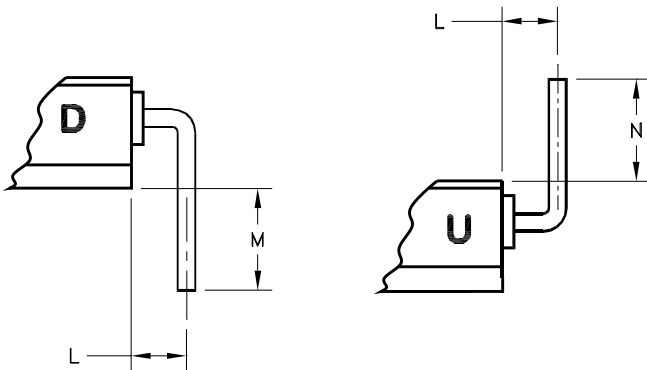
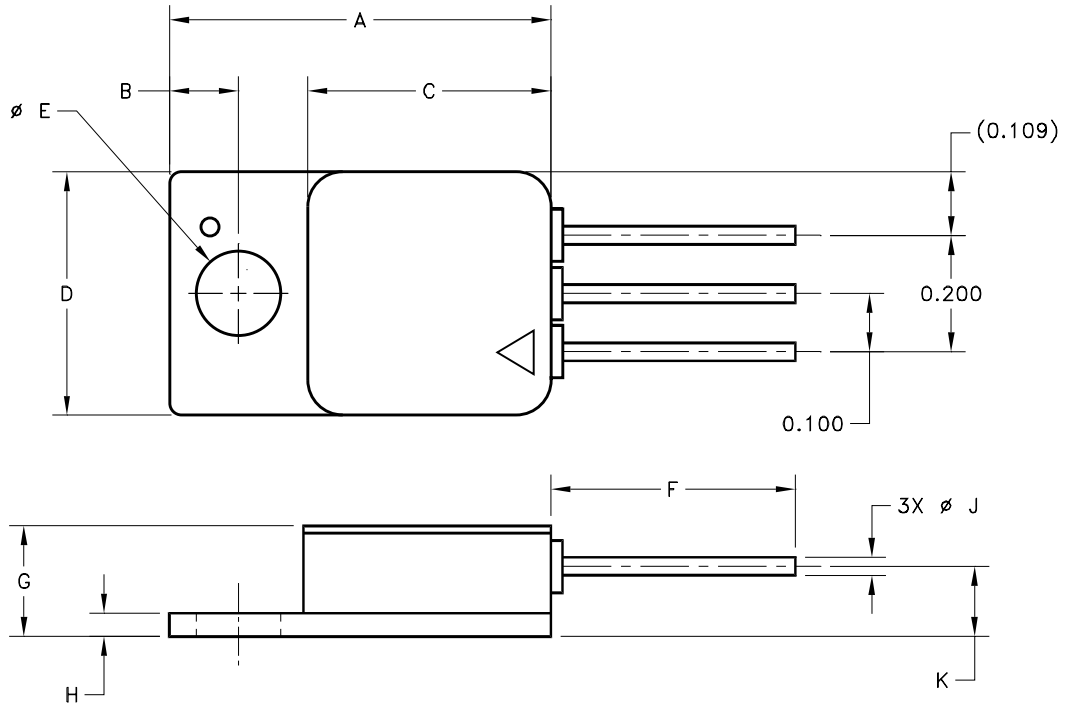

REF	MIN	MAX	REF	MIN	MAX
A	0.645	0.665	H	0.035	0.045
B	0.113	0.123	J	0.029	0.033
C	0.407	0.427	K	0.110	0.130
D	0.407	0.427	L	0.085	0.105
E	0.140	0.150	M	0.175	
F	0.400		N	0.175	
G		0.210			

ESD TRIANGLE INDICATES PIN 1
WEIGHT=3.2 GRAMS TYPICAL

ALL DIMENSIONS ARE SPECIFIED IN INCHES

ORDERING INFORMATION

MSK5979 K RH U

LEAD CONFIGURATIONS

S= STRAIGHT; U= BENT UP; D= BENT DOWN

RADIATION HARDENED

SCREENING

BLANK= INDUSTRIAL

H=MIL-PRF-38534 CLASS H

K=MIL-PRF-38534 CLASS K

GENERAL PART NUMBER

The above example is an adjustable Class K regulator with leads bent up.

REVISION HISTORY

REV	STATUS	DATE	DESCRIPTION
-	Released	07/14	Initial Release
A	Released	10/14	Add pin 1 indicator on page 7
B	Released	08/14	Add ESD rating to absolute maximum ratings.

MSK
www.anaren.com/msk

The information contained herein is believed to be accurate at the time of printing. MSK reserves the right to make changes to its products or specifications without notice, however, and assumes no liability for the use of its products. Please visit our website for the most recent revision of this datasheet.
Contact MSK for MIL-PRF-38534 Class K qualification status.