

## Kinetis K28F MCU Sub-Family

High performance ARM® Cortex®-M4 MCU with 2 MB Flash, 1 MB SRAM, 2 USB Controllers (High-Speed and Full-Speed), SDRAM controller, QuadSPI interface and Power Management Controller with Core Voltage Bypass.

K28F extends the Kinetis Microcontroller portfolio with large embedded memory, advanced external memory interfaces, performance, and peripheral integration while maintaining a high level of software compatibility with previous Kinetis devices:

- The extended memory resources include a total of 2 MB of programmable flash and 1 MB of embedded SRAM which can be used to support application needs for data logging and rich human to machine interfaces with displays
- The Power Management Controller with Core Voltage Bypass enables the use of an external PMIC to maximize the power efficiency of the system
- K28F enables memory expansion leveraging the SDRAM controller and QuadSPI interface for eXecution-In-Place (XIP) from an external Serial NOR flash
- Both the USB High-Speed and Crystal-less Full-Speed Controllers integrate a PHY to reduce BOM cost
- The integrated smart peripherals such as Low-power UARTs and Timers operate in very low-power modes to optimize battery life of the system

MK28FN2M0ACAU15R  
MK28FN2M0AVMI15



169 MAPBGA (MI)  
9 x 9 x 1.28 mm Pitch  
0.65 mm

210 WLCSP (AU)  
6.9 mm x 6.9 x 0.6 mm  
Pitch 0.4 mm

### Performance

- Up to 150 MHz ARM Cortex-M4 based core with DSP instructions and Single Precision Floating Point unit (FPU)

### Memories and memory expansion

- 2 MB dual bank program flash and 1 MB SRAM
- 8 KB I/D + 8 KB System cache
- 32-bit external bus interface (FlexBus)
- 32-bit SDRAM controller
- Dual QuadSPI interface with eXecution-In-Place (XIP)
  - supports SDR and DDR serial flash and octal configurations
- 32 KB Boot ROM with built-in bootloader

### System and Clocks

- 32-ch Asynchronous DMA
- Multiple low-power modes
- Memory protection unit with multi-master protection
- 3 to 32 MHz main crystal oscillator
- 32 kHz low power crystal oscillator
- 48 MHz internal reference
- Hardware and Software Watchdogs

### Human-machine interface

- Up to 120 General-purpose input/output (GPIOs)

### Analog modules

- Power Management Control (PMC) with Core Voltage Bypass
- One 16-bit SAR ADCs, two 6-bit DAC and one 12-bit DAC
- Two analog comparators (CMP) containing a 6-bit DAC and programmable reference input
- 1.2 V Voltage reference

### Timers

- One 4-ch 32-bit Periodic interrupt timer
- Two 16-bit low-power timer PWM modules
- Two 8-ch motor control/general purpose/PWM timers
- Two 2-ch quadrature decoder/general purpose timers
- Real-time clock with independent 3.6 V power domain
- Programmable delay block

### Operating Characteristics

- Temperature range (ambient): -40 to 105°C (BGA)
- Temperature range (ambient): -40 to 85°C (WLCSP)
- V<sub>DD</sub> Voltage/Flash write voltage range: 1.71 V–3.6 V

## Security

- Hardware random-number generator
- Memory Mapped Crypto Acceleration Unit(MMCAU): DES, 3-DES, AES, SHA-1, SHA-256 and MD5 accelerator
- Cyclic Redundancy Check (CRC)

## Target Applications

- Wearables
- Low-end graphic display system
- Cost-optimized multi-standard wireless smart home hubs
- Home Automation devices
- Consumer accessories

- $V_{DD\_CORE}$ : 1.17 V–1.47 V
- Independent  $V_{DDIO\_E}$  (QuadSPI): 1.71 V–3.6 V
- Independent  $V_{BAT}$  (RTC): 1.71 V–3.6 V
- I/O Voltage range ( $V_{DD}$ ): 1.71 V–3.6 V

## Communication interfaces

- Two USB controllers: Crystal-less Full-/low-speed + transceiver Host and Device; High-/Full-/low-speed + PHY Host and Device
- Secure Digital Host Controller (SDHC)
- Two I2S modules, four I2C modules and five Low-Power UART modules
- Four SPI modules (SPI3 supports more than 40 Mbps)
- 32-ch Programmable module (FlexIO) to emulate various serial, parallel or custom interfaces

## Ordering Information 1

Part Number	Embedded Memory		Package Type	Maximum number of I/O's
	Flash	SRAM		
MK28FN2M0AVMI15	2 MB	1 MB	169 MAPBGA	120
MK28FN2M0ACAU15R	2 MB	1 MB	210 WLCSP	120

1. To confirm current availability of orderable part numbers, go to <http://www.nxp.com> and perform a part number search.

## Device Revision Number

Device Mask Set Number	SIM_SDID[REVID]	JTAG ID Register[PRN]
3N96T	0011	0011

## Related Resources

Type	Description	Resource
Fact Sheet	The Fact Sheet gives overview of the product key features and its uses.	<a href="#">K2x Fact Sheet</a>
Reference Manual	The Reference Manual contains a comprehensive description of the structure and function (operation) of a device.	<a href="#">K28P210M150SF5RM<sup>1</sup></a>
Data Sheet	The Data Sheet includes electrical characteristics and signal connections.	This document
Chip Errata	The chip mask set Errata provides additional or corrective information for a particular device mask set.	<a href="#">KINETIS_K_3N96T<sup>1</sup></a>
Package drawing	Package dimensions are provided in package drawings.	<ul style="list-style-type: none"><li>• MAPBGA 169-pin: <a href="#">98ASA00628D<sup>1</sup></a></li><li>• WLCSP 210-pin: <a href="#">98ASA01002D<sup>1</sup></a></li></ul>

1. To find the associated resource, go to <http://www.nxp.com> and perform a search using this term.

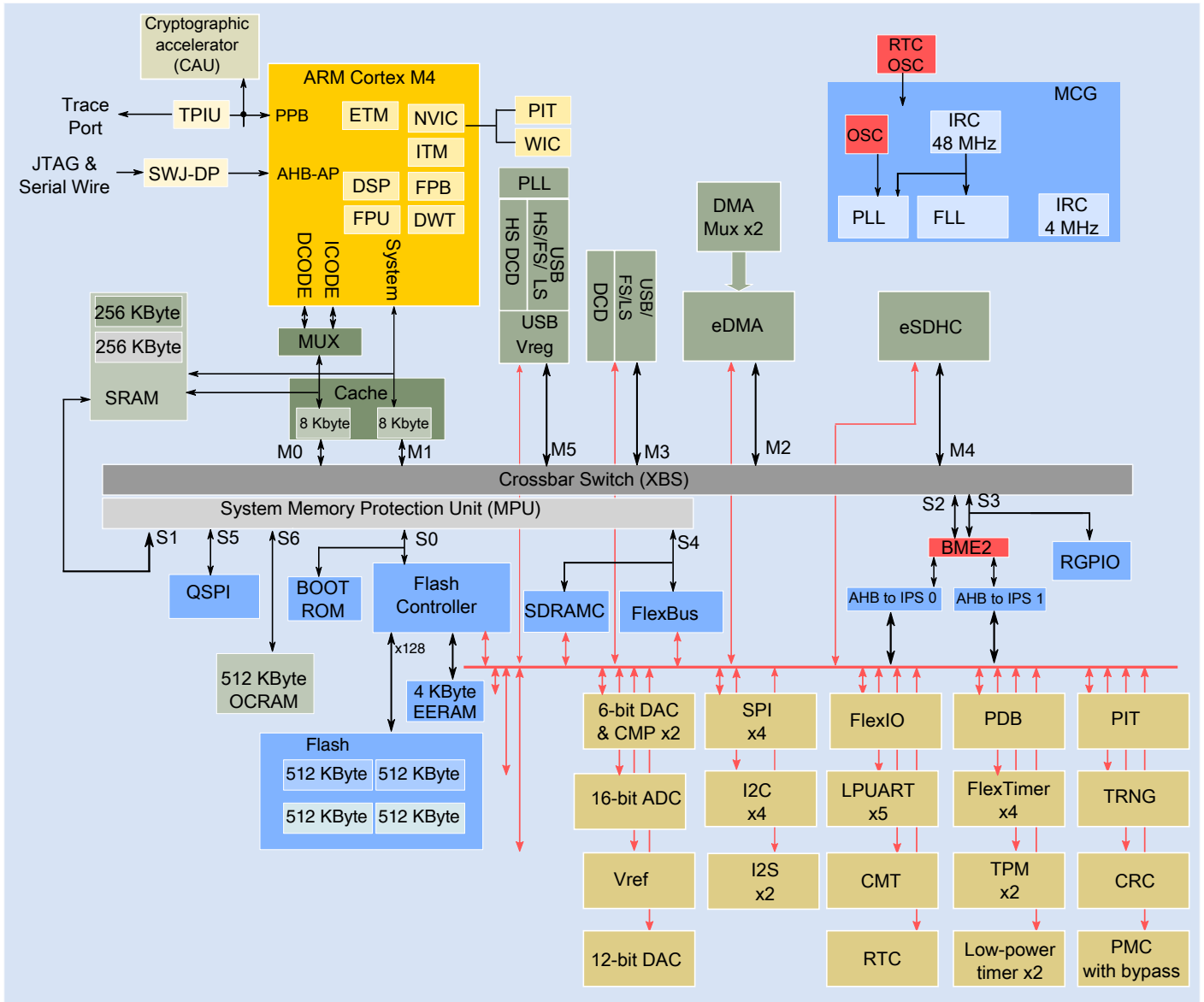

Figure 1. K28F Block Diagram

# Table of Contents

1	Ratings.....	5	3.4.1	ADC electrical specifications.....	50
1.1	Thermal handling ratings.....	5	3.4.2	CMP and 6-bit DAC electrical specifications.....	54
1.2	Moisture handling ratings.....	5	3.4.3	12-bit DAC electrical characteristics.....	57
1.3	ESD handling ratings.....	5	3.4.4	Voltage reference electrical specifications.....	60
1.4	Voltage and current maximum ratings.....	5	3.5	Timers.....	61
1.4.1	Recommended Power-On-Reset (POR) Sequencing .....	6	3.6	Communication interfaces.....	61
2	General.....	7	3.6.1	USB Voltage Regulator electrical specifications..	61
2.1	AC electrical characteristics.....	7	3.6.2	USB Full Speed Transceiver and High Speed PHY specifications.....	62
2.2	Nonswitching electrical specifications.....	7	3.6.3	USB DCD electrical specifications.....	63
2.2.1	Voltage and current operating requirements.....	7	3.6.4	DSPI switching specifications (limited voltage range).....	64
2.2.2	HVD, LVD and POR operating requirements.....	8	3.6.5	DSPI switching specifications (full voltage range).....	67
2.2.3	Voltage and current operating behaviors.....	9	3.6.6	Inter-Integrated Circuit Interface (I2C) timing.....	69
2.2.4	Power mode transition operating behaviors.....	11	3.6.7	LPUART switching specifications.....	71
2.2.5	Power consumption operating behaviors.....	12	3.6.8	SDHC specifications.....	71
2.2.6	Electromagnetic Compatibility (EMC) specifications.....	23	3.6.9	I2S switching specifications.....	73
2.2.7	Designing with radiated emissions in mind.....	23	4	Dimensions.....	79
2.2.8	Capacitance attributes.....	23	4.1	Obtaining package dimensions.....	79
2.3	Switching specifications.....	23	5	Pinout.....	79
2.3.1	Device clock specifications.....	23	5.1	K28F Signal Multiplexing and Pin Assignments.....	79
2.3.2	General switching specifications.....	24	5.2	Recommended connection for unused analog and digital pins.....	80
2.4	Thermal specifications.....	26	5.3	K28F Pinouts.....	81
2.4.1	Thermal operating requirements.....	26	6	Ordering parts.....	81
2.4.2	Thermal attributes.....	26	6.1	Determining valid orderable parts.....	81
3	Peripheral operating requirements and behaviors.....	27	7	Part identification.....	82
3.1	Core modules.....	27	7.1	Description.....	82
3.1.1	Debug trace timing specifications.....	27	7.2	Format.....	82
3.1.2	JTAG electricals.....	28	7.3	Fields.....	82
3.2	Clock modules.....	31	7.4	Example.....	83
3.2.1	MCG specifications.....	31	8	Terminology and guidelines.....	83
3.2.2	IRC48M specifications.....	34	8.1	Definitions.....	83
3.2.3	Oscillator electrical specifications.....	35	8.2	Examples.....	84
3.2.4	32 kHz oscillator electrical characteristics.....	37	8.3	Typical-value conditions.....	84
3.3	Memories and memory interfaces.....	37	8.4	Relationship between ratings and operating requirements.....	85
3.3.1	QuadSPI AC specifications.....	37	8.5	Guidelines for ratings and operating requirements.....	85
3.3.2	Flash electrical specifications.....	43	9	Revision History.....	86
3.3.3	Flexbus switching specifications.....	45			
3.3.4	SDRAM controller specifications.....	47			
3.4	Analog.....	50			

# 1 Ratings

## 1.1 Thermal handling ratings

Symbol	Description	Min.	Max.	Unit	Notes
T <sub>STG</sub>	Storage temperature	-55	150	°C	1
T <sub>SDR</sub>	Solder temperature, lead-free	—	260	°C	2

1. Determined according to JEDEC Standard JESD22-A103, *High Temperature Storage Life*.
2. Determined according to IPC/JEDEC Standard J-STD-020, *Moisture/Reflow Sensitivity Classification for Nonhermetic Solid State Surface Mount Devices*.

## 1.2 Moisture handling ratings

Symbol	Description	Min.	Max.	Unit	Notes
MSL	Moisture sensitivity level (for V-temp variant)	—	3	—	1
MSL	Moisture sensitivity level (for C-temp variant)	—	1	—	1

1. Determined according to IPC/JEDEC Standard J-STD-020, *Moisture/Reflow Sensitivity Classification for Nonhermetic Solid State Surface Mount Devices*.

## 1.3 ESD handling ratings

Symbol	Description	Min.	Max.	Unit	Notes
V <sub>HBM</sub>	Electrostatic discharge voltage, human body model	-2000	+2000	V	1
V <sub>CDM</sub>	Electrostatic discharge voltage, charged-device model	-500	+500	V	2
I <sub>LAT</sub>	Latch-up current at ambient temperature of 105°C	-100	+100	mA	3

1. Determined according to JEDEC Standard JESD22-A114, *Electrostatic Discharge (ESD) Sensitivity Testing Human Body Model (HBM)*.
2. Determined according to JEDEC Standard JESD22-C101, *Field-Induced Charged-Device Model Test Method for Electrostatic-Discharge-Withstand Thresholds of Microelectronic Components*.
3. Determined according to JEDEC Standard JESD78, *IC Latch-Up Test*.

## 1.4 Voltage and current maximum ratings

## Ratings

Symbol	Description	Min.	Max.	Unit
$V_{DD\_CORE}$ <sup>1</sup>	Internal digital logic supply voltage	-0.3	1.47	V
$V_{DD}$	Digital supply voltage for Ports A, B,C,D	-0.3	3.8	V
$V_{DDA}$	Analog supply voltage	-0.3	3.8	V
$V_{DDIO\_E}$	$V_{DDIO\_E}$ is an independent voltage supply for PORTE <sup>2</sup>	-0.3	3.8	V
$V_{BAT}$	RTC supply voltage	-0.3	3.8	V
$I_{DD}$	Digital supply current	—	300	mA
$I_D$	Maximum current single pin limit (digital output pins)	-25	25	mA
$V_{REGIN}$	USB regulator input	-0.3	6.0	V
$V_{USB0\_Dx}$	USB0_DP and USB0_DM input voltage	-0.3	3.63	V
$V_{USB1\_DPx}$	USB1_DP and USB1_DM input voltage	-0.3	3.63	V

- $V_{DD\_CORE}$  must not exceed  $V_{DD}$  on power up or power down
- $V_{DDIO\_E}$  is independent of the  $V_{DD}$  domain and can operate at a voltage independent of  $V_{DD}$ .

### 1.4.1 Recommended Power-On-Reset (POR) Sequencing

- $V_{DD}/V_{DDIO\_E}$  and  $V_{DD\_CORE}$

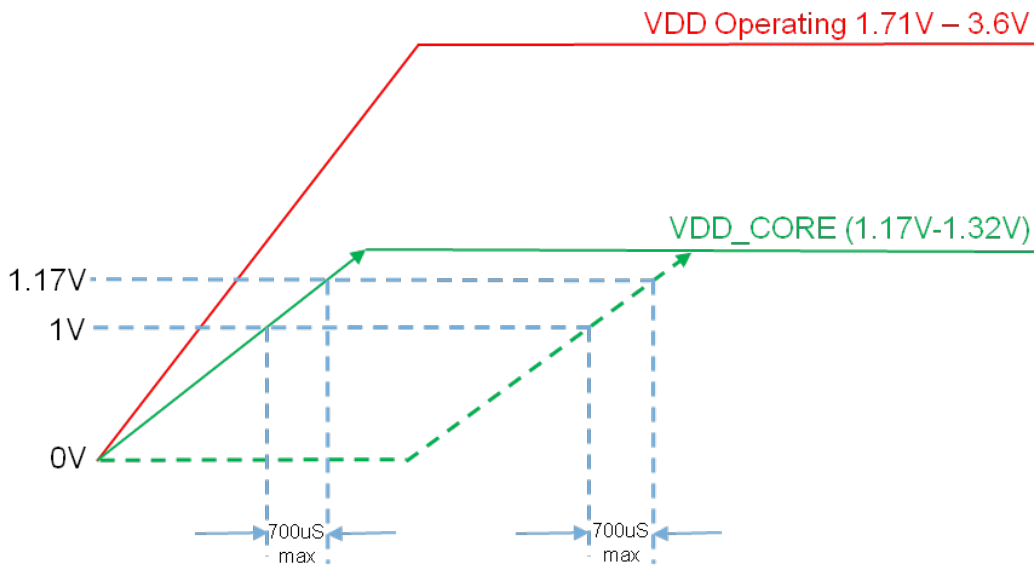

$V_{DD\_CORE}$  can be powered up either with  $V_{DD}$  or after  $V_{DD}$ .  
 $V_{DD\_CORE}$  on power up at any time must not exceed  $V_{DD}$  voltage  
 $V_{DD\_CORE}$  must rise from 1.0V to 1.17V at the rate of 242V/s (170mV/700uS) or faster.

**Figure 2.  $V_{DD\_CORE}/V_{DD}$  Powering sequence**

## 2 General

### 2.1 AC electrical characteristics

Unless otherwise specified, propagation delays are measured from the 50% to the 50% point, and rise and fall times are measured at the 20% and 80% points, as shown in the following figure.

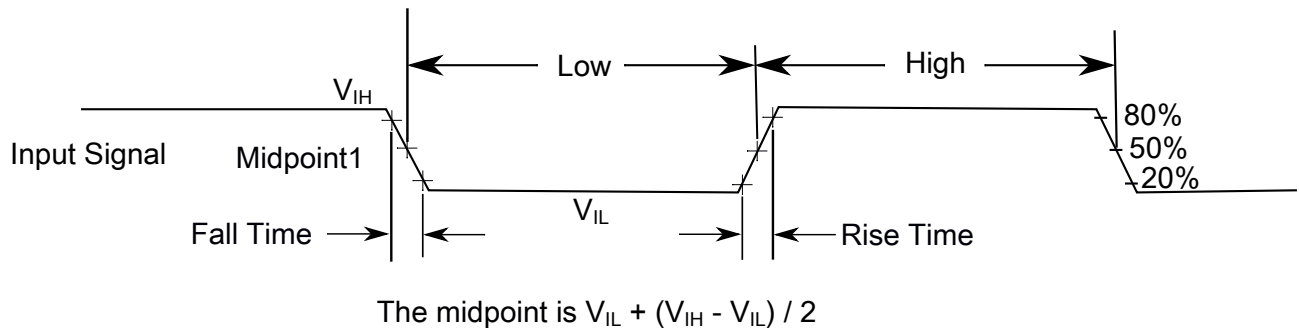

**Figure 3. Input signal measurement reference**

All digital I/O switching characteristics assume:

1. output pins
  - have  $C_L=15$  pF loads,
  - are slew rate disabled, and
  - are normal drive strength
2. input pins
  - have their passive filter disabled ( $PORTx\_PCRn[PFE]=0$ )

## 2.2 Nonswitching electrical specifications

### 2.2.1 Voltage and current operating requirements

**Table 1. Voltage and current operating requirements**

Symbol	Description	Min.	Max.	Unit	Notes
$V_{DD\_CORE}$ (RUN)	Core and digital logic supply voltage for RUN mode	1.17	1.32	V	
$V_{DD\_CORE}$ (HSRUN)	Core and digital logic supply voltage for HSRUN	1.33	1.47	V	

*Table continues on the next page...*

**Table 1. Voltage and current operating requirements (continued)**

Symbol	Description	Min.	Max.	Unit	Notes
V <sub>DD</sub>	Digital supply voltage for Ports A, B, C,D	1.71	3.6	V	
V <sub>DDIO_E</sub>	Digital Supply voltage for Port E	1.71	3.6	V	
V <sub>DDA</sub>	Analog supply voltage	1.71	3.6	V	
V <sub>DD</sub> – V <sub>DDA</sub>	V <sub>DD</sub> -to-V <sub>DDA</sub> differential voltage	-0.1	0.1	V	
V <sub>SS</sub> – V <sub>SSA</sub>	V <sub>SS</sub> -to-V <sub>SSA</sub> differential voltage	-0.1	0.1	V	
V <sub>BAT</sub>	RTC battery supply voltage	1.71	3.6	V	
V <sub>IH</sub>	Input high voltage <ul style="list-style-type: none"> <li>• 2.7 V ≤ V<sub>DD</sub> ≤ 3.6 V</li> <li>• 1.7 V ≤ V<sub>DD</sub> ≤ 2.7 V</li> </ul>	0.7 × V <sub>DD</sub> 0.75 × V <sub>DD</sub>	— —	V V	
V <sub>IL</sub>	Input low voltage <ul style="list-style-type: none"> <li>• 2.7 V ≤ V<sub>DD</sub> ≤ 3.6 V</li> <li>• 1.7 V ≤ V<sub>DD</sub> ≤ 2.7 V</li> </ul>	— —	0.35 × V <sub>DD</sub> 0.3 × V <sub>DD</sub>	V V	
V <sub>IH_E</sub>	Input high voltage <ul style="list-style-type: none"> <li>• 2.7 V ≤ V<sub>DDIO_E</sub> ≤ 3.6 V</li> <li>• 1.7 V ≤ V<sub>DDIO_E</sub> ≤ 2.7 V</li> </ul>	0.7 × V <sub>DDIO_E</sub> 0.75 × V <sub>DDIO_E</sub>	— —	V V	
V <sub>IL_E</sub>	Input low voltage <ul style="list-style-type: none"> <li>• 2.7 V ≤ V<sub>DDIO_E</sub> ≤ 3.6 V</li> <li>• 1.7 V ≤ V<sub>DDIO_E</sub> ≤ 2.7 V</li> </ul>	— —	0.35 × V <sub>DDIO_E</sub> 0.3 × V <sub>DDIO_E</sub>	V V	
V <sub>HYS</sub>	Input hysteresis	0.06 × V <sub>DD</sub>	—	V	
V <sub>HYS_E</sub>	Input hysteresis	0.06 × V <sub>DDIO_E</sub>	—	V	
I <sub>ICIO</sub>	I/O pin negative DC injection current — single pin <ul style="list-style-type: none"> <li>• V<sub>IN</sub> &lt; V<sub>SS</sub>-0.3V</li> </ul>	-5	—	mA	1
I <sub>ICcont</sub>	Contiguous pin DC injection current —regional limit, includes sum of negative injection currents or sum of positive injection currents of 16 contiguous pins <ul style="list-style-type: none"> <li>• Negative current injection</li> </ul>	-25	—	mA	
V <sub>ODPU</sub>	Pseudo Open drain pullup voltage level	V <sub>DD</sub>	V <sub>DD</sub>	V	2
V <sub>RAM</sub>	V <sub>DD_CORE</sub> voltage required to retain RAM	1.14	1.47	V	
V <sub>RFVBAT</sub>	V <sub>BAT</sub> voltage required to retain the VBAT register file	V <sub>POR_VBAT</sub>	—	V	

1. All I/O pins are internally clamped to V<sub>SS</sub> through an ESD protection diode. There is no diode connection to V<sub>DD</sub> or V<sub>DDIO\_E</sub>. If V<sub>IN</sub> is less than -0.3V, a current limiting resistor is required. The negative DC injection current limiting resistor is calculated as R=(-0.3-V<sub>IN</sub>)/|I<sub>ICIO</sub>|. The actual resistor value should be an order of magnitude higher to tolerate transient voltages.
2. Open drain outputs must be pulled to VDD.

## 2.2.2 HVD, LVD and POR operating requirements

Table 2.  $V_{DD}$  supply HVD, LVD and POR operating requirements

Symbol	Description	Min.	Typ.	Max.	Unit	Notes
$V_{HVDH}$	High Voltage Detect (High Trip Point)	—	3.72	—	V	
$V_{HVDL}$	High Voltage Detect (Low Trip Point)	—	3.46	—	V	
$V_{POR}$	Falling VDD POR detect voltage	0.8	1.1	1.5	V	
$V_{LVDH}$	Falling low-voltage detect threshold — high range (LVDV=01)	2.48	2.56	2.64	V	
$V_{LVW1H}$	Low-voltage warning thresholds — high range <ul style="list-style-type: none"> <li>• Level 1 falling (LVWV=00)</li> <li>• Level 2 falling (LVWV=01)</li> <li>• Level 3 falling (LVWV=10)</li> <li>• Level 4 falling (LVWV=11)</li> </ul>	2.62	2.70	2.78	V	1
$V_{LVW2H}$		2.72	2.80	2.88	V	
$V_{LVW3H}$		2.82	2.90	2.98	V	
$V_{LVW4H}$		2.92	3.00	3.08	V	
$V_{HYSH}$	Low-voltage inhibit reset/recover hysteresis — high range	—	60	—	mV	
$V_{LVDL}$	Falling low-voltage detect threshold — low range (LVDV=00)	1.54	1.60	1.66	V	
$V_{LVW1L}$	Low-voltage warning thresholds — low range <ul style="list-style-type: none"> <li>• Level 1 falling (LVWV=00)</li> <li>• Level 2 falling (LVWV=01)</li> <li>• Level 3 falling (LVWV=10)</li> <li>• Level 4 falling (LVWV=11)</li> </ul>	1.74	1.80	1.86	V	1
$V_{LVW2L}$		1.84	1.90	1.96	V	
$V_{LVW3L}$		1.94	2.00	2.06	V	
$V_{LVW4L}$		2.04	2.10	2.16	V	
$V_{HYSL}$	Low-voltage inhibit reset/recover hysteresis — low range	—	40	—	mV	
$V_{BG}$	Bandgap voltage reference	0.97	1.00	1.03	V	
$t_{LPO}$	Internal low power oscillator period — factory trimmed	900	1000	1100	$\mu$ s	

1. Rising threshold is the sum of falling threshold and hysteresis voltage

### NOTE

There is no LVD circuit for  $V_{DDIO\_E}$  and  $V_{DD\_CORE}$  domain.

Table 3. VBAT power operating requirements

Symbol	Description	Min.	Typ.	Max.	Unit	Notes
$V_{POR\_VBAT}$	Falling VBAT supply POR detect voltage	0.8	1.1	1.5	V	

## 2.2.3 Voltage and current operating behaviors

**Table 4. Voltage and current operating behaviors**

Symbol	Description	Min.	Typ. <sup>1</sup>	Max.	Unit	Notes
$V_{OH}$	Output high voltage — normal drive strength					2, 3
	IO Group 1	$V_{BAT} - 0.5$	—	—	V	
	• $2.7\text{ V} \leq V_{BAT} \leq 3.6\text{ V}$ , $I_{OH} = -5\text{ mA}$	$V_{BAT} - 0.5$	—	—	V	
	• $1.71\text{ V} \leq V_{BAT} \leq 2.7\text{ V}$ , $I_{OH} = -2.5\text{ mA}$					
	IO Groups 2 and 3	$V_{DD} - 0.5$	—	—	V	
	• $2.7\text{ V} \leq V_{DD} \leq 3.6\text{ V}$ , $I_{OH} = -10\text{ mA}$	$V_{DD} - 0.5$	—	—	V	
	• $1.71\text{ V} \leq V_{DD} \leq 2.7\text{ V}$ , $I_{OH} = -5\text{ mA}$					
	IO Group 4	$V_{DDIO\_E} - 0.5$	—	—	V	
	• $2.7\text{ V} \leq V_{DDIO\_E} \leq 3.6\text{ V}$ , $I_{OH} = -5\text{ mA}$	$V_{DDIO\_E} - 0.5$	—	—	V	
	• $1.71\text{ V} \leq V_{DDIO\_E} \leq 2.7\text{ V}$ , $I_{OH} = -2.5\text{ mA}$					
$I_{OHT}$	Output high voltage — High drive strength					2
	IO Group 3	$V_{DD} - 0.5$	—	—	V	
	• $2.7\text{ V} \leq V_{DD} \leq 3.6\text{ V}$ , $I_{OH} = -20\text{ mA}$	$V_{DD} - 0.5$	—	—	V	
	• $1.71\text{ V} \leq V_{DD} \leq 2.7\text{ V}$ , $I_{OH} = -10\text{ mA}$					
	IO Group 4	$V_{DDIO\_E} - 0.5$	—	—	V	
	• $2.7\text{ V} \leq V_{DDIO\_E} \leq 3.6\text{ V}$ , $I_{OH} = -15\text{ mA}$	$V_{DDIO\_E} - 0.5$	—	—	V	
• $1.71\text{ V} \leq V_{DDIO\_E} \leq 2.7\text{ V}$ , $I_{OH} = -7.5\text{ mA}$						
	Output high current total for all ports	—	—	100	mA	
$V_{OL}$	Output low voltage — normal drive strength					2, 4, 5
	IO Group 1	—	—	0.5	V	
	• $2.7\text{ V} \leq V_{BAT} \leq 3.6\text{ V}$ , $I_{OL} = -5\text{ mA}$	—	—	0.5	V	
	• $1.71\text{ V} \leq V_{BAT} \leq 2.7\text{ V}$ , $I_{OL} = -2.5\text{ mA}$					
	IO Groups 2 and 3	—	—	0.5	V	
	• $2.7\text{ V} \leq V_{DD} \leq 3.6\text{ V}$ , $I_{OL} = -10\text{ mA}$	—	—	0.5	V	
	• $1.71\text{ V} \leq V_{DD} \leq 2.7\text{ V}$ , $I_{OL} = -5\text{ mA}$					
	IO Group 4	—	—	0.5	V	
	• $2.7\text{ V} \leq V_{DDIO\_E} \leq 3.6\text{ V}$ , $I_{OL} = -5\text{ mA}$	—	—	0.5	V	
	• $1.71\text{ V} \leq V_{DDIO\_E} \leq 2.7\text{ V}$ , $I_{OL} = -2.5\text{ mA}$					
$I_{OLT}$	Output low voltage — High drive strength					2, 4
	IO Group 3	—	—	0.5	V	
	• $2.7\text{ V} \leq V_{DD} \leq 3.6\text{ V}$ , $I_{OL} = -20\text{ mA}$	—	—	0.5	V	
	• $1.71\text{ V} \leq V_{DD} \leq 2.7\text{ V}$ , $I_{OL} = -10\text{ mA}$					
	IO Group 4	—	—	0.5	V	
	• $2.7\text{ V} \leq V_{DDIO\_E} \leq 3.6\text{ V}$ , $I_{OL} = -15\text{ mA}$	—	—	0.5	V	
• $1.71\text{ V} \leq V_{DDIO\_E} \leq 2.7\text{ V}$ , $I_{OL} = -7.5\text{ mA}$						
	Output low current total for all ports	—	—	100	mA	
$I_{IN}$	Input leakage current					6, 7, 8

Table continues on the next page...

**Table 4. Voltage and current operating behaviors (continued)**

Symbol	Description	Min.	Typ. <sup>1</sup>	Max.	Unit	Notes
	$V_{DD}$ domain pins • $V_{SS} \leq V_{IN} \leq V_{DD}$	—	0.002	0.5	$\mu A$	
	PORTE pins • $V_{SS} \leq V_{IN} \leq V_{DDIO\_E}$	—	0.002	0.5	$\mu A$	
	$V_{BAT}$ domain pins • $V_{SS} \leq V_{IN} \leq V_{BAT}$	—	0.002	0.5	$\mu A$	
$R_{PU}$	Internal pullup resistors(except RTC_WAKEUP pins)	20	—	50	$k\Omega$	9
$R_{PD}$	Internal pulldown resistors (except RTC_WAKEUP pins)	20	—	50	$k\Omega$	10

1. Typical values characterized at 25°C and  $V_{DD} = 3.6V$  unless otherwise noted.
2. IO Group 1 includes  $V_{BAT}$  domain pins: RTC\_WAKEUP\_b. IO Group 2 includes  $V_{DD}$  domain pins: PORTA, PORTB, PORTC, and PORTD, except PTA4. IO Group 3 includes  $V_{DD}$  domain pins: PTB0, PTB1, PTC3, PTC4, PTD4, PTD5, PTD6, and PTD7. IO Group 4 includes  $V_{DDIO\_E}$  domain pins: PORTE.
3. PTA4 has lower drive strength:  $I_{OH} = -5$  mA for high  $V_{DD}$  range;  $I_{OH} = -2.5$  mA for low  $V_{DD}$  range.
4. Open drain outputs must be pulled to  $V_{DD}$ .
5. PTA4 has lower drive strength:  $I_{OL} = 5$  mA for high  $V_{DD}$  range;  $I_{OL} = 2.5$  mA for low  $V_{DD}$  range.
6.  $V_{DD}$  domain pins include ADC, CMP, and RESET\_b inputs. Measured at  $V_{DD} = 3.6V$ .
7. PORTE analog input voltages cannot exceed  $V_{DDIO\_E}$  supply when  $V_{DD} \geq V_{DDIO\_E}$ . PORTE analog input voltages cannot exceed  $V_{DD}$  supply when  $V_{DD} < V_{DDIO\_E}$ .
8.  $V_{BAT}$  domain pins include XTAL32, XTAL32, and RTC\_WAKEUP\_b pins.
9. Measured at minimum supply voltage and  $V_{IN} = V_{SS}$
10. Measured at minimum supply voltage and  $V_{IN} = V_{DD}$

## 2.2.4 Power mode transition operating behaviors

All specifications except  $t_{POR}$ , and VLLSx → RUN recovery times in the following table assume this clock configuration:

- CPU and system clocks = 100 MHz
- Bus clock = 50 MHz
- FlexBus clock = 50 MHz
- Flash clock = 25 MHz
- MCG mode=FEI

### NOTE

VLLS1 and VLLS0 are not supported.

**Table 5. Power mode transition operating behaviors**

Symbol	Description	Min.	Max.	Unit	Notes
t <sub>POR</sub>	After a POR event, amount of time from the point V <sub>DD</sub> reaches 1.71 V and VDD_CORE reaches 1.17 V to execution of the first instruction across the operating temperature range of the chip.	—	1200	μs	
	• VLLS2 → RUN	—	103	μs	
	• VLLS3 → RUN	—	103	μs	
	• LLS2 → RUN	—	6.3	μs	
	• LLS3 → RUN	—	6.3	μs	
	• VLPS → RUN	—	5.4	μs	
	• STOP → RUN	—	5.4	μs	

### 2.2.5 Power consumption operating behaviors

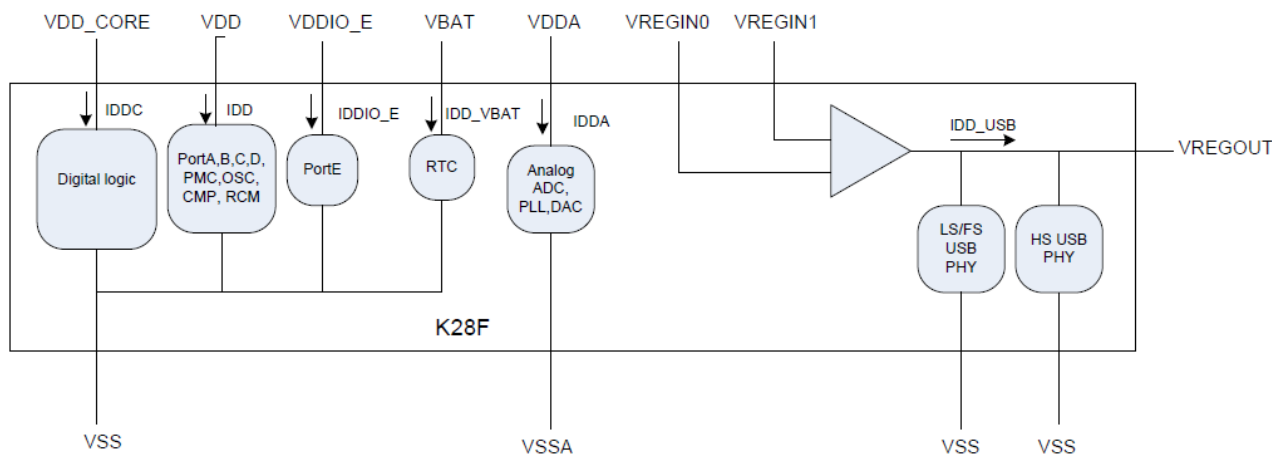

**Figure 4. Power Supplies of K28F**

The K28F device has several power supplies and the total current consumption of the device is the accumulative result of each individual power supplies' current consumption, dependent on the power mode of operation. (RUN, HSRUN, VLPR, Stop, VLLS3 etc.).

$$IDD\_MCU\_total = IDDC + IDD + IDDIO\_E + IDD\_VBAT + IDDA + IDD\_USB$$

When calculating the total MCU current consumption considerations to external loads on the following should be made:

- On top of the device's IDD current consumption, external loads applied to Ports A,B,C and D need to be considered
- IDDIO\_E current consumption is significantly dependent on external loads applied to Port E pins, and the internal current consumption in the device is negligible compared to IDD.
- The USB\_VREG provides a 3.3 V output which can drive loads of upto 150 mA need to be considered.

The maximum values stated in the following table represent characterized results equivalent to the mean plus three times the standard deviation (mean + 3 sigma).

[Table 6](#) details the IDDC values observed through the VDD\_CORE supply and [Table 7](#) details the IDD values observed through the VDD supply.

**Table 6. Power consumption operating behaviors (through VDD\_CORE)**

Symbol	Description	Min.	Typ.	Max.	Unit	Notes
I <sub>DDA</sub>	Analog supply current	—	—	See note	mA	1
I <sub>DDC_RUN</sub>	Run mode current — all peripheral clocks disabled, code of while(1) loop executing from internal flash at 1.2 V <ul style="list-style-type: none"> <li>• @ 25°C</li> <li>• @ 70°C</li> <li>• @ 85°C</li> <li>• @ 105°C</li> </ul>	—	31.0 37.9 42.7 51.9	35.1 51.6 63.6 85.7	mA	2
I <sub>DDC_RUN</sub>	Run mode current — all peripheral clocks enabled, code of while(1) loop executing from internal flash at 1.2 V <ul style="list-style-type: none"> <li>• @ 25°C</li> <li>• @ 70°C</li> <li>• @ 85°C</li> <li>• @ 105°C</li> </ul>	—	41.6 48.0 52.6 61.1	47.1 65.5 78.4 100.9	mA	2
I <sub>DDC_RUNCO</sub>	Run mode current in compute operation - 120 MHz core / 24 MHz flash / bus clock disabled, code of while(1) loop executing from internal flash at 1.2 V <ul style="list-style-type: none"> <li>• @ 25°C</li> <li>• @ 70°C</li> <li>• @ 85°C</li> <li>• @ 105°C</li> </ul>	—	28.5 35.5 40.3 49.5	32.4 48.4 60.1 81.6	mA	3

*Table continues on the next page...*

**Table 6. Power consumption operating behaviors (through VDD\_CORE) (continued)**

Symbol	Description	Min.	Typ.	Max.	Unit	Notes
$I_{DDC\_HSRUN}$	High-speed Run mode current — all peripheral clocks disabled, code of while(1) loop executing from internal flash at 1.4 V <ul style="list-style-type: none"> <li>• @ 25°C</li> <li>• @ 70°C</li> <li>• @ 85°C</li> <li>• @ 105°C</li> </ul>	—	42.6	49.6	mA	4
		—	53.5	74.9		
		—	59.7	91.3		
		—	71.7	121.0		
$I_{DDC\_HSRUN}$	High-speed Run mode current — all peripheral clocks enabled, code of while(1) loop executing from internal flash at 1.4 V <ul style="list-style-type: none"> <li>• @ 25°C</li> <li>• @ 70°C</li> <li>• @ 85°C</li> <li>• @ 105°C</li> </ul>	—	54.3	63.3	mA	4
		—	65.7	91.9		
		—	71.5	109.8		
		—	82.6	139.0		
$I_{DDC\_HSRUNCO}$	High-speed Run mode current in compute operation – 150 MHz core/ 25 MHz flash / bus clock disabled, code of while(1) loop executing from internal flash at 1.4 V <ul style="list-style-type: none"> <li>• @ 25°C</li> <li>• @ 70°C</li> <li>• @ 85°C</li> <li>• @ 105°C</li> </ul>	—	40.5	47.2	mA	3
		—	50.7	70.9		
		—	57.1	87.2		
		—	68.7	115.7		
$I_{DDC\_WAIT}$	Wait mode high frequency current at 1.2 V— all peripheral clocks disabled <ul style="list-style-type: none"> <li>• @ 25°C</li> <li>• @ 70°C</li> <li>• @ 85°C</li> <li>• @ 105°C</li> </ul>	—	15.6	17.7	mA	2
		—	23.2	31.6		
		—	28.3	42.2		
		—	38.1	62.8		
$I_{DDC\_WAIT}$	Wait mode reduced frequency current at 1.2 V— all peripheral clocks disabled <ul style="list-style-type: none"> <li>• @ 25°C</li> <li>• @ 70°C</li> <li>• @ 85°C</li> <li>• @ 105°C</li> </ul>	—	7.0	7.9	mA	5
		—	15.0	20.4		
		—	20.3	30.3		
		—	30.5	50.4		
$I_{DDC\_VLPR}$	Very-low-power run mode current at 1.2 V — all peripheral clocks disabled, code of while(1) loop executing out of internal flash	—	1.2	3.9	mA	6

Table continues on the next page...

**Table 6. Power consumption operating behaviors (through VDD\_CORE) (continued)**

Symbol	Description	Min.	Typ.	Max.	Unit	Notes
	<ul style="list-style-type: none"> <li>• @ 25°C</li> <li>• @ 70°C</li> <li>• @ 85°C</li> <li>• @ 105°C</li> </ul>	—	2.6	7.1		
I <sub>DDC_VLPR</sub>	Very-low-power run mode current at 1.2 V — all peripheral clocks enabled, code of while(1) loop executing out of internal flash <ul style="list-style-type: none"> <li>• @ 25°C</li> <li>• @ 70°C</li> <li>• @ 85°C</li> <li>• @ 105°C</li> </ul>	—	1.7	5.5	mA	6
I <sub>DDC_VLPRCO</sub>	Very-low-power run mode current in compute operation - 4 MHz core / 1 MHz flash / bus clock disabled, code of while(1) loop executing from internal flash at 1.2 V <ul style="list-style-type: none"> <li>• @ 25°C</li> <li>• @ 70°C</li> <li>• @ 85°C</li> <li>• @ 105°C</li> </ul>	—	1.1	3.6	mA	7
I <sub>DDC_PSTOP2</sub>	Stop mode current with partial stop 2 clocking option - core and system disabled / 10.5 MHz bus at 1.2 V <ul style="list-style-type: none"> <li>• @ 25°C</li> <li>• @ 70°C</li> <li>• @ 85°C</li> <li>• @ 105°C</li> </ul>	—	4.4	14.2	mA	3
I <sub>DDC_VLPW</sub>	Very-low-power wait mode current at 1.2 V — all peripheral clocks disabled <ul style="list-style-type: none"> <li>• @ 25°C</li> <li>• @ 70°C</li> <li>• @ 85°C</li> <li>• @ 105°C</li> </ul>	—	0.759	2.5	mA	6
I <sub>DDC_VLWP</sub>	Very-low-power wait mode current at 1.2 V— all peripheral clocks enabled <ul style="list-style-type: none"> <li>• @ 25°C</li> <li>• @ 70°C</li> <li>• @ 85°C</li> <li>• @ 105°C</li> </ul>	—	1.2	4.0	mA	6
I <sub>DDC_STOP</sub>	Stop mode current at 1.2 V					

Table continues on the next page...

**Table 6. Power consumption operating behaviors (through VDD\_CORE) (continued)**

Symbol	Description	Min.	Typ.	Max.	Unit	Notes
	<ul style="list-style-type: none"> <li>• @ 25°C</li> <li>• @ 70°C</li> <li>• @ 85°C</li> <li>• @ 105°C</li> </ul>	—	0.749	1.9	mA	
I <sub>DDC_VLPS</sub>	Very-low-power stop mode current at 1.2 V <ul style="list-style-type: none"> <li>• @ 25°C</li> <li>• @ 70°C</li> <li>• @ 85°C</li> <li>• @ 105°C</li> </ul>	—	0.452	1.2	mA	
I <sub>DDC_LLS3</sub>	Low leakage stop mode current at 1.2 V <ul style="list-style-type: none"> <li>• @ 25°C</li> <li>• @ 70°C</li> <li>• @ 85°C</li> <li>• @ 105°C</li> </ul>	—	15.6	30.3	μA	
I <sub>DDC_LLS2</sub>	Low leakage stop mode current at 1.2 V <ul style="list-style-type: none"> <li>• @ 25°C</li> <li>• @ 70°C</li> <li>• @ 85°C</li> <li>• @ 105°C</li> </ul>	—	4.3	8.7	μA	8
I <sub>DDC_VLLS3</sub>	Very low-leakage stop mode 3 current at 1.2 V <ul style="list-style-type: none"> <li>• @ 25°C</li> <li>• @ 70°C</li> <li>• @ 85°C</li> <li>• @ 105°C</li> </ul>	—	13.5	26.0	μA	
I <sub>DDC_VLLS2</sub>	Very low-leakage stop mode 2 current at 1.2 V <ul style="list-style-type: none"> <li>• @ 25°C</li> <li>• @ 70°C</li> <li>• @ 85°C</li> <li>• @ 105°C</li> </ul>	—	0.552	0.9	μA	8
I <sub>DD_VBAT</sub>	Average current with RTC and 32 kHz disabled @ 3.0 V <ul style="list-style-type: none"> <li>• @ 25°C</li> <li>• @ 70°C</li> </ul>	—	0.266	0.319	μA	

Table continues on the next page...

**Table 6. Power consumption operating behaviors (through VDD\_CORE) (continued)**

Symbol	Description	Min.	Typ.	Max.	Unit	Notes
	<ul style="list-style-type: none"> <li>• @ 85°C</li> <li>• @ 105°C</li> </ul>	—	0.933	1.3		
		—	2.2	2.8		
I <sub>DD_VBAT</sub>	Average current when CPU is not accessing RTC registers @ 1.8 V <ul style="list-style-type: none"> <li>• @ 25°C</li> <li>• @ 70°C</li> <li>• @ 85°C</li> <li>• @ 105°C</li> </ul>	—	0.454	0.546	μA	9
		—	0.724	0.897		
		—	1.1	1.4		
		—	2.0	2.6		

1. The analog supply current is the sum of the active or disabled current for each of the analog modules on the device. See each module's specification for its supply current.
2. 120 MHz core and system clock, 60 MHz bus and FlexBus clock, and 24 MHz flash clock. MCG configured for PEE mode.
3. MCG configured for PEE mode.
4. 150 MHz core and system clock, 50 MHz bus and FlexBus clock, and 25 MHz flash clock. MCG configured for PEE mode.
5. 25 MHz core and system clock, 25 MHz bus and FlexBus clock, and 25 MHz flash clock. MCG configured for FEI mode.
6. 4 MHz core, system, FlexBus, and bus clock and 1 MHz flash clock. MCG configured for BLPE mode using an 8 MHz external reference clock. Code executing from flash.
7. MCG configured for BLPE mode using an 8 MHz external reference clock.
8. By default, this mode only has 32 K of SRAM enabled.
9. Includes 32 kHz oscillator current and RTC operation.

**Table 7. Power consumption operating behaviors (through VDD)**

Symbol	Description	Min.	Typ.	Max.	Unit	Notes
I <sub>DD_RUN</sub>	Run mode current — all peripheral clocks disabled, code of while(1) loop executing from internal flash @ 3.0 V <ul style="list-style-type: none"> <li>• @ 25°C</li> <li>• @ 70°C</li> <li>• @ 85°C</li> <li>• @ 105°C</li> </ul>	—	2.0	2.1	mA	1
		—	2.0	2.1		
		—	2.0	2.1		
		—	2.0	2.1		
I <sub>DD_RUN</sub>	Run mode current — all peripheral clocks enabled, code of while(1) loop executing from internal flash @ 3.0 V <ul style="list-style-type: none"> <li>• @ 25°C</li> <li>• @ 70°C</li> <li>• @ 85°C</li> <li>• @ 105°C</li> </ul>	—	2.0	2.1	mA	1
		—	2.0	2.1		
		—	2.0	2.1		
		—	2.0	2.1		

Table continues on the next page...

**Table 7. Power consumption operating behaviors (through VDD) (continued)**

Symbol	Description	Min.	Typ.	Max.	Unit	Notes
I <sub>DD_RUNCO</sub>	Run mode current in compute operation - 120 MHz core / 24 MHz flash / bus clock disabled, code of while(1) loop executing from internal flash at 3.0 V <ul style="list-style-type: none"> <li>• @ 25°C</li> <li>• @ 70°C</li> <li>• @ 85°C</li> <li>• @ 105°C</li> </ul>	—	1.5	1.6	mA	2
I <sub>DD_HSRUN</sub>	Run mode current — all peripheral clocks disabled, code of while(1) loop executing from internal flash @ 3.0 V <ul style="list-style-type: none"> <li>• @ 25°C</li> <li>• @ 70°C</li> <li>• @ 85°C</li> <li>• @ 105°C</li> </ul>	—	2.0	2.1	mA	3
I <sub>DD_HSRUN</sub>	Run mode current — all peripheral clocks enabled, code of while(1) loop executing from internal flash @ 3.0 V <ul style="list-style-type: none"> <li>• @ 25°C</li> <li>• @ 70°C</li> <li>• @ 85°C</li> <li>• @ 105°C</li> </ul>	—	2.0	2.1	mA	3
I <sub>DD_HSRUNCO</sub>	HSRun mode current in compute operation – 150 MHz core/ 25 MHz flash / bus clock disabled, code of while(1) loop executing from internal flash at 3.0 V <ul style="list-style-type: none"> <li>• @ 25°C</li> <li>• @ 70°C</li> <li>• @ 85°C</li> <li>• @ 105°C</li> </ul>	—	2.0	2.1	mA	2
I <sub>DD_WAIT</sub>	Wait mode high frequency current at 3.0 V — all peripheral clocks disabled <ul style="list-style-type: none"> <li>• @ 25°C</li> <li>• @ 70°C</li> <li>• @ 85°C</li> <li>• @ 105°C</li> </ul>	—	2.0	2.1	mA	1

Table continues on the next page...

Table 7. Power consumption operating behaviors (through VDD) (continued)

Symbol	Description	Min.	Typ.	Max.	Unit	Notes
I <sub>DD_WAIT</sub>	Wait mode reduced frequency current at 3.0 V — all peripheral clocks disabled <ul style="list-style-type: none"> <li>• @ 25°C</li> <li>• @ 70°C</li> <li>• @ 85°C</li> <li>• @ 105°C</li> </ul>	—	2.0	2.1	mA	4
		—	2.0	2.1		
		—	2.0	2.1		
		—	2.0	2.1		
I <sub>DD_VLPR</sub>	Very-low-power run mode current at 3.0 V — all peripheral clocks disabled <ul style="list-style-type: none"> <li>• @ 25°C</li> <li>• @ 70°C</li> <li>• @ 85°C</li> <li>• @ 105°C</li> </ul>	—	24.9	48.0	μA	5
		—	31.2	70.1		
		—	39.6	84.5		
		—	63.9	157.5		
I <sub>DD_VLPR</sub>	Very-low-power run mode current at 3.0 V — all peripheral clocks enabled <ul style="list-style-type: none"> <li>• @ 25°C</li> <li>• @ 70°C</li> <li>• @ 85°C</li> <li>• @ 105°C</li> </ul>	—	25.2	48.6	μA	5
		—	31.5	70.6		
		—	40.0	85.0		
		—	64.3	158.4		
I <sub>DD_VLPRCO</sub>	Very-low-power run mode current in compute operation - 4 MHz core / 0.8 MHz flash / bus clock disabled, while(1) code executing from internal flash at 3.0 V <ul style="list-style-type: none"> <li>• @ 25°C</li> <li>• @ 70°C</li> <li>• @ 85°C</li> <li>• @ 105°C</li> </ul>	—	8.3	16.0	μA	6
		—	14.4	32.3		
		—	22.7	48.5		
		—	47.0	115.8		
I <sub>DD_PSTOP2</sub>	Stop mode current with partial stop 2 clocking option - core and system disabled / 10.5 MHz bus at 3.0 V <ul style="list-style-type: none"> <li>• @ 25°C</li> <li>• @ 70°C</li> <li>• @ 85°C</li> <li>• @ 105°C</li> </ul>	—	1.8	3.5	mA	2
		—	1.8	4.1		
		—	1.9	3.9		
		—	1.9	4.6		
I <sub>DD_VLPW</sub>	Very-low-power wait mode current at 3.0 V — all peripheral clocks disabled <ul style="list-style-type: none"> <li>• @ 25°C</li> <li>• @ 70°C</li> </ul>	—	24.9	47.8	μA	5
		—	31.0	69.5		

Table continues on the next page...

**Table 7. Power consumption operating behaviors (through VDD) (continued)**

Symbol	Description	Min.	Typ.	Max.	Unit	Notes
	<ul style="list-style-type: none"> <li>• @ 85°C</li> <li>• @ 105°C</li> </ul>	—	39.2	83.6		
	<ul style="list-style-type: none"> <li>• @ 25°C</li> <li>• @ 70°C</li> <li>• @ 85°C</li> <li>• @ 105°C</li> </ul>	—	63.7	157.0		
I <sub>DD_VLPW</sub>	Very-low-power wait mode current at 3.0 V — all peripheral clocks enabled <ul style="list-style-type: none"> <li>• @ 25°C</li> <li>• @ 70°C</li> <li>• @ 85°C</li> <li>• @ 105°C</li> </ul>	—	25.0	48.1	μA	5
		—	31.2	70.0		
		—	39.6	84.3		
		—	63.9	157.5		
I <sub>DD_STOP</sub>	Stop mode current at 3.0 V <ul style="list-style-type: none"> <li>• @ 25°C</li> <li>• @ 70°C</li> <li>• @ 85°C</li> <li>• @ 105°C</li> </ul>	—	159.3	279.3	μA	
		—	173.8	341.8		
		—	181.4	358.4		
		—	251.2	735.0		
I <sub>DD_VLPS</sub>	Very-low-power stop mode current at 3.0 V <ul style="list-style-type: none"> <li>• @ 25°C</li> <li>• @ 70°C</li> <li>• @ 85°C</li> <li>• @ 105°C</li> </ul>	—	3.1	5.6	μA	
		—	8.5	12.0		
		—	15.2	19.4		
		—	36.9	43.9		
I <sub>DD_LLS3</sub>	Low leakage stop mode current at 3.0 V <ul style="list-style-type: none"> <li>• @ 25°C</li> <li>• @ 70°C</li> <li>• @ 85°C</li> <li>• @ 105°C</li> </ul>	—	2.9	4.7	μA	
		—	7.2	9.2		
		—	13.2	16.1		
		—	33.4	39.4		
I <sub>DD_LLS2</sub>	Low leakage stop mode current at 3.0 V <ul style="list-style-type: none"> <li>• @ 25°C</li> <li>• @ 70°C</li> <li>• @ 85°C</li> <li>• @ 105°C</li> </ul>	—	2.9	4.7	μA	7
		—	7.2	9.2		
		—	13.2	16.1		
		—	33.4	39.4		
I <sub>DD_VLLS3</sub>	Very low-leakage stop mode 3 current at 3.0 V <ul style="list-style-type: none"> <li>• @ 25°C</li> <li>• @ 70°C</li> </ul>	—	2.2	3.4	μA	
		—	4.7	6.4		

Table continues on the next page...

**Table 7. Power consumption operating behaviors (through VDD) (continued)**

Symbol	Description	Min.	Typ.	Max.	Unit	Notes
	<ul style="list-style-type: none"> <li>@ 85°C</li> <li>@ 105°C</li> </ul>	—	8.1	10.6		
		—	18.8	23.8		
I <sub>DD_VLLS2</sub>	Very low-leakage stop mode 2 current at 3.0 V <ul style="list-style-type: none"> <li>@ 25°C</li> <li>@ 70°C</li> <li>@ 85°C</li> <li>@ 105°C</li> </ul>	—	2.2	3.3	μA	7
		—	4.5	6.1		
		—	7.7	10.0		
		—	17.5	22.0		

- 120 MHz core and system clock, 60 MHz bus and FlexBus clock, and 24 MHz flash clock. MCG configured for PEE mode.
- MCG configured for PEE mode.
- 150 MHz core and system clock, 50 MHz bus and FlexBus clock, and 25 MHz flash clock. MCG configured for PEE mode.
- 25 MHz core and system clock, 25 MHz bus and FlexBus clock, and 25 MHz flash clock. MCG configured for FEI mode.
- 4 MHz core, system, FlexBus, and bus clock and 1 MHz flash clock. MCG configured for BLPE mode using an 8 MHz external reference clock. Code executing from flash.
- MCG configured for BLPE mode using an 8 MHz external reference clock.
- By default, this mode has only 32K of SRAM enabled.

Below table list the current consumption adders for different SRAM configurations from the LLS2/VLLS2 (TYP) IDD values using a 32 KB SRAM retention referenced in [Table 6](#).

**Table 8. LLS2/VLLS2 additional Typical IDDC current consumption Adders**

RAM array retained		@ 25°C	@ 85°C	@ 105°C	Unit
LLS2	RAM2: 32 KB	0.5	10.8	21.3	μA
	RAM3: 32 KB	0.5	11.0	21.5	μA
	RAM4: 32 KB	0.4	10.7	21.0	μA
	RAM5: 128 KB	1.4	28.1	57.6	μA
	RAM6: 64 KB	0.6	15.2	30.5	μA
	RAM7: 192 KB	2.1	41.1	85.1	μA
	RAM8: 256 KB	2.8	53.0	109.9	μA
	RAM9: 256 KB	2.3	53.5	110.9	μA
	VLLS2	RAM2: 32 KB	0.5	9.1	19.7
RAM3: 32 KB		0.5	8.5	18.0	μA
RAM4: 32 KB		0.5	8.1	16.8	μA
RAM5: 128 KB		1.5	26.6	57.1	μA
RAM6: 64 KB		0.8	12.9	27.1	μA
RAM7: 192 KB		2.3	40.2	86.6	μA

Table continues on the next page...

**Table 8. LLS2/VLLS2 additional Typical IDDC current consumption Adders (continued)**

RAM array retained		@ 25°C	@ 85°C	@ 105°C	Unit
	RAM8: 256 KB	3.0	52.9	114.3	μA
	RAM9: 256 KB	3.0	53.1	114.8	μA

**Table 9. Low power mode peripheral adders — typical value**

Symbol	Description	Temperature (°C)						Unit
		-40	25	50	70	85	105	
I <sub>IREFSTEN4MHZ</sub>	4 MHz internal reference clock (IRC) adder. Measured by entering STOP or VLPS mode with 4 MHz IRC enabled.	56	56	56	56	56	56	μA
I <sub>IREFSTEN32KHz</sub>	32 kHz internal reference clock (IRC) adder. Measured by entering STOP mode with the 32 kHz IRC enabled.	52	52	52	52	52	52	μA
I <sub>EREFSTEN4MHZ</sub>	External 4 MHz crystal clock adder. Measured by entering STOP or VLPS mode with the crystal enabled.	206	228	237	245	251	258	uA
I <sub>EREFSTEN32KHz</sub>	External 32 kHz crystal clock adder by means of the OSC0_CR[EREFSTEN and EREFSTEN] bits. Measured by entering all modes with the crystal enabled.							nA
	VLLS3	440	490	540	560	570	580	
	LLS2	490	490	540	560	570	680	
	LLS3	490	490	540	560	570	680	
	VLPS	510	560	560	560	610	680	
	STOP	510	560	560	560	610	680	
I <sub>CMP</sub>	CMP peripheral adder measured with CMP enabled using the 6-bit DAC and a single external input for compare. Includes 6-bit DAC power consumption.	22	22	22	22	22	22	μA
I <sub>RTC</sub>	RTC peripheral adder measured with external 32 kHz crystal enabled by means of the RTC_CR[OSCE] bit and the RTC ALARM set for 1 minute. Includes ERCLK32K (32 kHz external crystal) power consumption.	432	357	388	475	532	810	nA
I <sub>LPUART</sub>	LPUART peripheral adder measured by placing the device in STOP or VLPS mode with selected clock source waiting for RX data at 115200 baud rate. Includes selected clock source power consumption.							μA
	MCGIRCLK (4 MHz internal reference clock)	66	66	66	66	66	66	
	OSCERCLK (4 MHz external crystal)	214	234	246	254	260	268	

Table continues on the next page...

**Table 9. Low power mode peripheral adders — typical value (continued)**

Symbol	Description	Temperature (°C)						Unit
		-40	25	50	70	85	105	
I <sub>BG</sub>	Bandgap adder when BGEN bit is set and device is placed in VLPx, LLS, or VLLSx mode.	45	45	45	45	45	45	μA
I <sub>ADC</sub>	ADC peripheral adder combining the measured values at V <sub>DD</sub> and V <sub>DDA</sub> by placing the device in STOP or VLPS mode. ADC is configured for low power mode using the internal clock and continuous conversions.	366	366	366	366	366	366	μA

## 2.2.6 Electromagnetic Compatibility (EMC) specifications

EMC measurements to IC-level IEC standards are available from NXP on request.

## 2.2.7 Designing with radiated emissions in mind

To find application notes that provide guidance on designing your system to minimize interference from radiated emissions.

1. Go to [nxp.com](http://nxp.com)
2. Perform a keyword search for “EMC design.”

## 2.2.8 Capacitance attributes

**Table 10. Capacitance attributes**

Symbol	Description	Min.	Max.	Unit
C <sub>IN_A</sub>	Input capacitance: analog pins	—	7	pF
C <sub>IN_D</sub>	Input capacitance: digital pins	—	7	pF

## 2.3 Switching specifications

## 2.3.1 Device clock specifications

**Table 11. Device clock specifications**

Symbol	Description	Min.	Max.	Unit	Notes
High Speed run mode					
$f_{SYS}$	System and core clock	—	150	MHz	
Normal run mode (and High Speed run mode unless otherwise specified above)					
$f_{SYS}$	System and core clock	—	120	MHz	
	System and core clock when Full Speed USB in operation	20	—	MHz	
$f_{SYS\_USBHS}$	System and core clock when High Speed USB in operation	100	—	MHz	
$f_{BUS}$	Bus clock	—	75	MHz	
$f_{B\_CLK}$	FlexBus clock	—	75	MHz	
$f_{FLASH}$	Flash clock	—	28	MHz	
$f_{LPTMR}$	LPTMR clock	—	25	MHz	
VLPR mode <sup>1</sup>					
$f_{SYS}$	System and core clock	—	4	MHz	
$f_{BUS}$	Bus clock	—	4	MHz	
$f_{B\_CLK}$	FlexBus clock	—	4	MHz	
$f_{FLASH}$	Flash clock	—	1	MHz	
$f_{ERCLK}$	External reference clock	—	16	MHz	
$f_{LPTMR\_pin}$	LPTMR clock	—	25	MHz	
$f_{I2S\_MCLK}$	I2S master clock	—	12.5	MHz	
$f_{I2S\_BCLK}$	I2S bit clock	—	4	MHz	

1. The frequency limitations in VLPR mode here override any frequency specification listed in the timing specification for any other module.

## 2.3.2 General switching specifications

These general purpose specifications apply to all signals configured for GPIO, LPUART, CMT, timers, and I<sup>2</sup>C signals.

**Table 12. General switching specifications**

Symbol	Description	Min.	Max.	Unit	Notes
	GPIO pin interrupt pulse width (digital glitch filter disabled) — Synchronous path	1.5	—	Bus clock cycles	1, 2
	NMI_b pin interrupt pulse width (analog filter enabled) — Asynchronous path	100	—	ns	
	GPIO pin interrupt pulse width (digital glitch filter disabled, analog filter disabled) — Asynchronous path	50	—	ns	3

*Table continues on the next page...*

**Table 12. General switching specifications (continued)**

Symbol	Description	Min.	Max.	Unit	Notes
	External RESET_b input pulse width (digital glitch filter disabled)	100	—	ns	
	Port rise and fall time (high drive strength) <ul style="list-style-type: none"> <li>Slew enabled <ul style="list-style-type: none"> <li><math>1.71 \leq V_{DD} \leq 2.7V</math></li> <li><math>2.7 \leq V_{DD} \leq 3.6V</math></li> </ul> </li> <li>Slew disabled <ul style="list-style-type: none"> <li><math>1.71 \leq V_{DD} \leq 2.7V</math></li> <li><math>2.7 \leq V_{DD} \leq 3.6V</math></li> </ul> </li> </ul>	— —	34 16	ns ns	4, 5
	Port rise and fall time (low drive strength) <ul style="list-style-type: none"> <li>Slew enabled <ul style="list-style-type: none"> <li><math>1.71 \leq V_{DD} \leq 2.7V</math></li> <li><math>2.7 \leq V_{DD} \leq 3.6V</math></li> </ul> </li> <li>Slew disabled <ul style="list-style-type: none"> <li><math>1.71 \leq V_{DD} \leq 2.7V</math></li> <li><math>2.7 \leq V_{DD} \leq 3.6V</math></li> </ul> </li> </ul>	— —	34 16	ns ns	6, 7
	Port rise and fall time (high drive strength) <ul style="list-style-type: none"> <li>Slew enabled <ul style="list-style-type: none"> <li><math>1.71 \leq V_{DDIO\_E} \leq 2.7V</math></li> <li><math>2.7 \leq V_{DDIO\_E} \leq 3.6V</math></li> </ul> </li> <li>Slew disabled <ul style="list-style-type: none"> <li><math>1.71 \leq V_{DDIO\_E} \leq 2.7V</math></li> <li><math>2.7 \leq V_{DDIO\_E} \leq 3.6V</math></li> </ul> </li> </ul>	— —	34 16	ns ns	5, 8
	Port rise and fall time (low drive strength) <ul style="list-style-type: none"> <li>Slew enabled <ul style="list-style-type: none"> <li><math>1.71 \leq V_{DDIO\_E} \leq 2.7V</math></li> <li><math>2.7 \leq V_{DDIO\_E} \leq 3.6V</math></li> </ul> </li> <li>Slew disabled <ul style="list-style-type: none"> <li><math>1.71 \leq V_{DDIO\_E} \leq 2.7V</math></li> <li><math>2.7 \leq V_{DDIO\_E} \leq 3.6V</math></li> </ul> </li> </ul>	— —	34 16	ns ns	7, 8

1. This is the minimum pulse width that is guaranteed to pass through the pin synchronization circuitry in run modes.
2. The greater synchronous and asynchronous timing must be met.
3. This is the minimum pulse width that is guaranteed to be recognized as a pin interrupt request in Stop, VLPS, LLS, and VLLSx modes.
4. PTB0, PTB1, PTC3, PTC4, PTD4, PTD5, PTD6, and PTD7.
5. 75 pF load.
6. Ports A, B, C, and D.
7. 25 pF load.

## General

8. Port E pins only.

## 2.4 Thermal specifications

### 2.4.1 Thermal operating requirements

**Table 13. Thermal operating requirements (for V-Temp range)**

Symbol	Description	Min.	Max.	Unit	Notes
T <sub>J</sub>	Die junction temperature	-40	125	°C	1
T <sub>A</sub>	Ambient temperature	-40	105	°C	

1. Maximum T<sub>A</sub> can be exceeded only if the user ensures that T<sub>J</sub> does not exceed the maximum. The simplest method to determine T<sub>J</sub> is:

$$T_J = T_A + R_{\theta JA} \times \text{chip power dissipation}$$

**Table 14. Thermal operating requirements (for C-Temp range)**

Symbol	Description	Min.	Max.	Unit	Notes
T <sub>J</sub>	Die junction temperature	-40	95	°C	1
T <sub>A</sub>	Ambient temperature	-40	85	°C	

1. Maximum T<sub>A</sub> can be exceeded only if the user ensures that T<sub>J</sub> does not exceed the maximum. The simplest method to determine T<sub>J</sub> is:

$$T_J = T_A + R_{\theta JA} \times \text{chip power dissipation}$$

### 2.4.2 Thermal attributes

**Table 15. Thermal attributes**

Board type	Symbol	Description	210 WLCSP	169 MAPBGA	Unit	Notes
Single-layer (1S)	R <sub>θJA</sub>	Thermal resistance, junction to ambient (natural convection)	68.5	56.8	°C/W	1
Four-layer (2s2p)	R <sub>θJA</sub>	Thermal resistance, junction to ambient (natural convection)	32.1	27.1	°C/W	1
Single-layer (1S)	R <sub>θJMA</sub>	Thermal resistance, junction to ambient (200 ft./min. air speed)	52.3	41	°C/W	1
Four-layer (2s2p)	R <sub>θJMA</sub>	Thermal resistance, junction to ambient (200 ft./min. air speed)	27.2	22.4	°C/W	1
—	R <sub>θJB</sub>	Thermal resistance, junction to board	16.0	10.4	°C/W	2

*Table continues on the next page...*

**Table 15. Thermal attributes (continued)**

Board type	Symbol	Description	210 WLCSP	169 MAPBGA	Unit	Notes
—	$R_{\theta JC}$	Thermal resistance, junction to case	1.3	7.1	°C/W	3
—	$\Psi_{JT}$	Thermal characterization parameter, junction to package top outside center (natural convection)	0.2	0.2	°C/W	4

1. Determined according to JEDEC Standard JESD51-2, *Integrated Circuits Thermal Test Method Environmental Conditions—Natural Convection (Still Air)* with the single layer board horizontal. Board meets JESD51-9 specification.
2. Determined according to JEDEC Standard JESD51-8, *Integrated Circuit Thermal Test Method Environmental Conditions—Junction-to-Board*.
3. Determined according to Method 1012.1 of MIL-STD 883, *Test Method Standard, Microcircuits*, with the cold plate temperature used for the case temperature. The value includes the thermal resistance of the interface material between the top of the package and the cold plate.
4. Determined according to JEDEC Standard JESD51-2, *Integrated Circuits Thermal Test Method Environmental Conditions—Natural Convection (Still Air)*.

## 3 Peripheral operating requirements and behaviors

### 3.1 Core modules

#### 3.1.1 Debug trace timing specifications

**Table 16. Debug trace operating behaviors**

Symbol	Description	Min.	Max.	Unit
$T_{cyc}$	Clock period	Frequency dependent		MHz
$T_{wl}$	Low pulse width	2	—	ns
$T_{wh}$	High pulse width	2	—	ns
$T_r$	Clock and data rise time	—	3	ns
$T_f$	Clock and data fall time	—	3	ns
$T_s$	Data setup	1.5	—	ns
$T_h$	Data hold	1.0	—	ns

## Peripheral operating requirements and behaviors

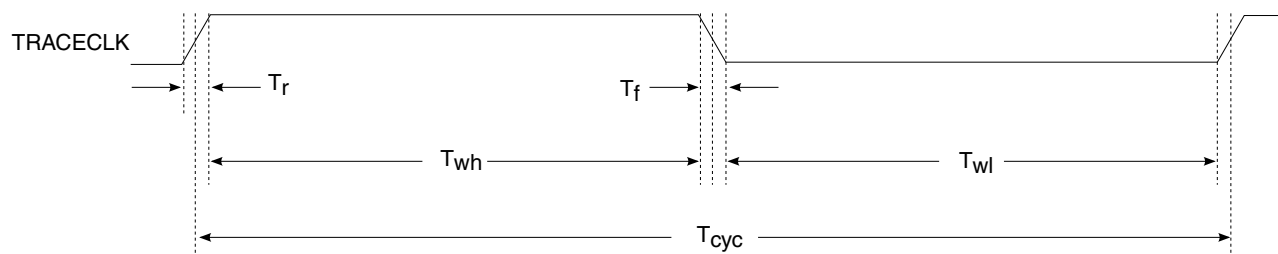

**Figure 5. TRACE\_CLKOUT specifications**

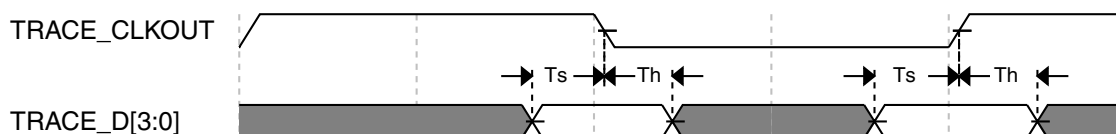

**Figure 6. Trace data specifications**

### 3.1.2 JTAG electricals

**Table 17. JTAG limited voltage range electricals**

Symbol	Description	Min.	Max.	Unit
	Operating voltage	2.7	3.6	V
J1	TCLK frequency of operation <ul style="list-style-type: none"> <li>• Boundary Scan</li> <li>• JTAG and CJTAG</li> <li>• Serial Wire Debug</li> </ul>	0	10	MHz
		0	25	
		0	50	
J2	TCLK cycle period	1/J1	—	ns
J3	TCLK clock pulse width <ul style="list-style-type: none"> <li>• Boundary Scan</li> <li>• JTAG and CJTAG</li> <li>• Serial Wire Debug</li> </ul>	50	—	ns
		20	—	ns
		10	—	ns
J4	TCLK rise and fall times	—	3	ns
J5	Boundary scan input data setup time to TCLK rise	20	—	ns
J6	Boundary scan input data hold time after TCLK rise	2.0	—	ns
J7	TCLK low to boundary scan output data valid	—	28	ns
J8	TCLK low to boundary scan output high-Z	—	25	ns
J9	TMS, TDI input data setup time to TCLK rise	8	—	ns
J10	TMS, TDI input data hold time after TCLK rise	1	—	ns

*Table continues on the next page...*

**Table 17. JTAG limited voltage range electricals (continued)**

Symbol	Description	Min.	Max.	Unit
J11	TCLK low to TDO data valid	—	19	ns
J12	TCLK low to TDO high-Z	—	17	ns
J13	$\overline{\text{TRST}}$ assert time	100	—	ns
J14	$\overline{\text{TRST}}$ setup time (negation) to TCLK high	8	—	ns

**Table 18. JTAG full voltage range electricals**

Symbol	Description	Min.	Max.	Unit
	Operating voltage	1.71	3.6	V
J1	TCLK frequency of operation <ul style="list-style-type: none"> <li>• Boundary Scan</li> <li>• JTAG and CJTAG</li> <li>• Serial Wire Debug</li> </ul>	0 0 0	10 20 40	MHz
J2	TCLK cycle period	1/J1	—	ns
J3	TCLK clock pulse width <ul style="list-style-type: none"> <li>• Boundary Scan</li> <li>• JTAG and CJTAG</li> <li>• Serial Wire Debug</li> </ul>	50 25 12.5	— — —	ns ns ns
J4	TCLK rise and fall times	—	3	ns
J5	Boundary scan input data setup time to TCLK rise	20	—	ns
J6	Boundary scan input data hold time after TCLK rise	2.0	—	ns
J7	TCLK low to boundary scan output data valid	—	30.6	ns
J8	TCLK low to boundary scan output high-Z	—	25	ns
J9	TMS, TDI input data setup time to TCLK rise	8	—	ns
J10	TMS, TDI input data hold time after TCLK rise	1.0	—	ns
J11	TCLK low to TDO data valid	—	19.0	ns
J12	TCLK low to TDO high-Z	—	17.0	ns
J13	$\overline{\text{TRST}}$ assert time	100	—	ns
J14	$\overline{\text{TRST}}$ setup time (negation) to TCLK high	8	—	ns

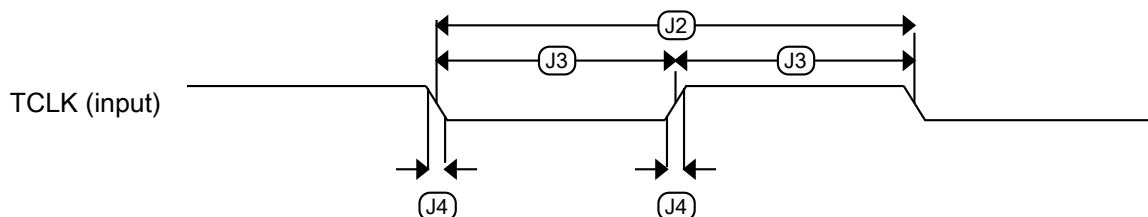
**Figure 7. Test clock input timing**

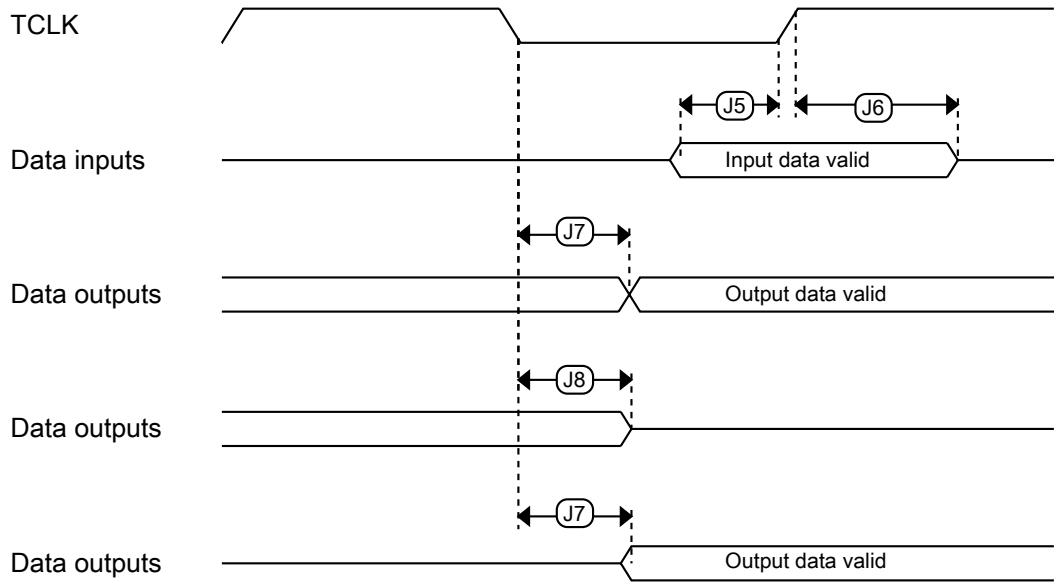

Figure 8. Boundary scan (JTAG) timing

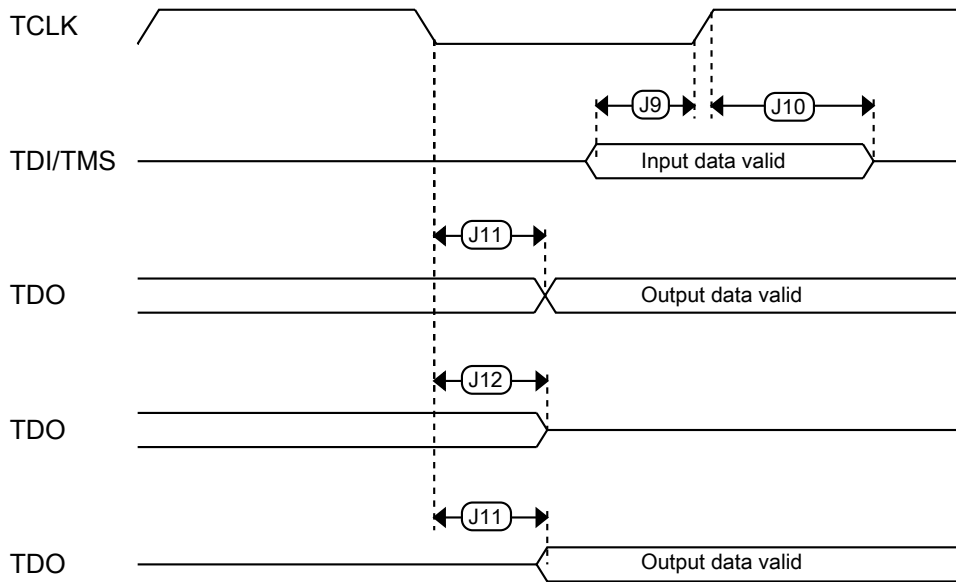

Figure 9. Test Access Port timing

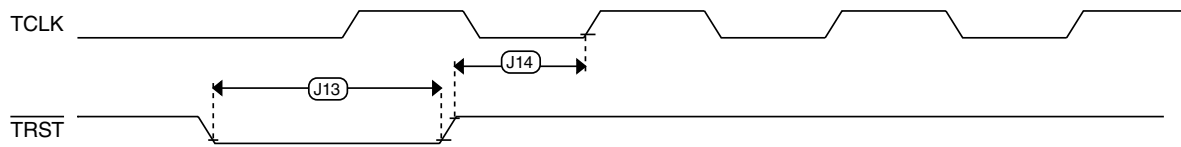

Figure 10. TRST timing

## 3.2 Clock modules

### 3.2.1 MCG specifications

Table 19. MCG specifications

Symbol	Description	Min.	Typ.	Max.	Unit	Notes
$f_{ints\_ft}$	Internal reference frequency (slow clock) — factory trimmed at nominal VDD and 25 °C	—	32.768	—	kHz	
$f_{ints\_t}$	Internal reference frequency (slow clock) — user trimmed	31.25	—	39.0625	kHz	
$I_{ints}$	Internal reference (slow clock) current	—	20	—	μA	
$t_{irefst}$	[O: ] Internal reference (slow clock) startup time	—	32	—	μs	
$\Delta f_{dco\_res\_t}$	Resolution of trimmed average DCO output frequency at fixed voltage and temperature — using SCTRIM and SCFTRIM	—	± 0.3	± 0.6	% $f_{dco}$	1
$\Delta f_{dco\_res\_t}$	Resolution of trimmed average DCO output frequency at fixed voltage and temperature — using SCTRIM only	—	± 0.2	± 0.5	% $f_{dco}$	1
$\Delta f_{dco\_t}$	Total deviation of trimmed average DCO output frequency over voltage and temperature	—	± 1	± 2	% $f_{dco}$	1
$\Delta f_{dco\_t}$	Total deviation of trimmed average DCO output frequency over fixed voltage and temperature range of 0–70°C	—	± 0.5	± 1	% $f_{dco}$	1
$f_{intf\_ft}$	Internal reference frequency (fast clock) — factory trimmed at nominal VDD and 25°C	—	4	—	MHz	
$f_{intf\_t}$	Internal reference frequency (fast clock) — user trimmed at nominal VDD and 25 °C	3	—	5	MHz	
$I_{intf}$	Internal reference (fast clock) current	—	25	—	μA	
$t_{irefst}$	[L: ] Internal reference startup time (fast clock)	—	10	15	μs	
$f_{loc\_low}$	Loss of external clock minimum frequency — RANGE = 00 ext clk freq: above $(3/5)f_{int}$ never reset	$(3/5) \times f_{ints\_t}$	—	—	kHz	

Table continues on the next page...

Table 19. MCG specifications (continued)

Symbol	Description	Min.	Typ.	Max.	Unit	Notes
	ext clk freq: between $(2/5)f_{int}$ and $(3/5)f_{int}$ maybe reset (phase dependency) ext clk freq: below $(2/5)f_{int}$ always reset					
$f_{loc\_high}$	Loss of external clock minimum frequency — RANGE = 01, 10, or 11 ext clk freq: above $(16/5)f_{int}$ never reset ext clk freq: between $(15/5)f_{int}$ and $(16/5)f_{int}$ maybe reset (phase dependency) ext clk freq: below $(15/5)f_{int}$ always reset	$(16/5) \times f_{ints\_t}$	—	—	kHz	
FLL						
$f_{fill\_ref}$	FLL reference frequency range	31.25	—	39.0625	kHz	
$f_{dco\_ut}$	DCO output frequency range — untrimmed				MHz	2
	Low range (DRS=00, DMX32=0) $640 \times f_{ints\_ut}$	16.0	23.04	26.66		
	Mid range (DRS=01, DMX32=0) $1280 \times f_{ints\_ut}$	32.0	46.08	53.32		
	Mid-high range (DRS=10, DMX32=0) $1920 \times f_{ints\_ut}$	48.0	69.12	79.99		
	High range (DRS=11, DMX32=0) $2560 \times f_{ints\_ut}$	64.0	92.16	106.65		
	Low range (DRS=00, DMX32=1) $732 \times f_{ints\_ut}$	18.3	26.35	30.50		
	Mid range (DRS=01, DMX32=1) $1464 \times f_{ints\_ut}$	36.6	52.70	60.99		
	Mid-high range (DRS=10, DMX32=1) $2197 \times f_{ints\_ut}$	54.93	79.09	91.53		
	High range (DRS=11, DMX32=1) $2929 \times f_{ints\_ut}$	73.23	105.44	122.02		
$f_{dco}$	DCO output frequency range				MHz	3, 4
	Low range (DRS=00) $640 \times f_{fill\_ref}$	20	20.97	25		
	Mid range (DRS=01)	40	41.94	50	MHz	

Table continues on the next page...

Table 19. MCG specifications (continued)

Symbol	Description	Min.	Typ.	Max.	Unit	Notes	
		$1280 \times f_{\text{fll\_ref}}$					
		Mid-high range (DRS=10)	60	62.91	75	MHz	
		$1920 \times f_{\text{fll\_ref}}$					
		High range (DRS=11)	80	83.89	100	MHz	
$f_{\text{dco\_t\_DMX3}}$ 2	DCO output frequency	Low range (DRS=00)	—	23.99	—	MHz	5, 6
		$732 \times f_{\text{fll\_ref}}$					
		Mid range (DRS=01)	—	47.97	—	MHz	
		$1464 \times f_{\text{fll\_ref}}$					
		Mid-high range (DRS=10)	—	71.99	—	MHz	
		$2197 \times f_{\text{fll\_ref}}$					
		High range (DRS=11)	—	95.98	—	MHz	
		$2929 \times f_{\text{fll\_ref}}$					
$J_{\text{cyc\_fll}}$	FLL period jitter	—	180	—	ps		
	<ul style="list-style-type: none"> <li><math>f_{\text{DCO}} = 48 \text{ MHz}</math></li> <li><math>f_{\text{DCO}} = 98 \text{ MHz}</math></li> </ul>	—	150	—			
$t_{\text{fll\_acquire}}$	FLL target frequency acquisition time	—	—	1	ms	7	
PLL							
$f_{\text{pll\_ref}}$	PLL reference frequency range	8	—	16	MHz		
$f_{\text{vcoclk\_2x}}$	VCO output frequency	180	—	360	MHz		
$f_{\text{vcoclk}}$	PLL output frequency	90	—	180	MHz		
$f_{\text{vcoclk\_90}}$	PLL quadrature output frequency	90	—	180	MHz		
$I_{\text{pll}}$	PLL operating current	—	1.1	—	mA	8	
	<ul style="list-style-type: none"> <li>VCO @ 176 MHz (<math>f_{\text{pll\_ref}} = 8 \text{ MHz}</math>, VDIV multiplier = 22, PRDIV divide=1)</li> </ul>						
$I_{\text{pll}}$	PLL operating current	—	2	—	mA	8	
	<ul style="list-style-type: none"> <li>VCO @ 360 MHz (<math>f_{\text{pll\_ref}} = 8 \text{ MHz}</math>, VDIV multiplier = 45, PRDIV divide=1)</li> </ul>						
$J_{\text{cyc\_pll}}$	PLL period jitter (RMS)	<ul style="list-style-type: none"> <li><math>f_{\text{vco}} = 180 \text{ MHz}</math></li> </ul>	—	100	—	ps	9
		<ul style="list-style-type: none"> <li><math>f_{\text{vco}} = 360 \text{ MHz}</math></li> </ul>	—	75	—	ps	
$J_{\text{acc\_pll}}$	PLL accumulated jitter over 1 $\mu$ s (RMS)	<ul style="list-style-type: none"> <li><math>f_{\text{vco}} = 180 \text{ MHz}</math></li> </ul>	—	600	—	ps	9
		<ul style="list-style-type: none"> <li><math>f_{\text{vco}} = 360 \text{ MHz}</math></li> </ul>	—	300	—	ps	
$D_{\text{unl}}$	Lock exit frequency tolerance	$\pm 4.47$	—	$\pm 5.97$	%		
$t_{\text{pll\_lock}}$	Lock detector detection time	—	—	$150 \times 10^{-6} + 1075(1/f_{\text{pll\_ref}})$	s	10	

## Peripheral operating requirements and behaviors

1. This parameter is measured with the internal reference (slow clock) being used as a reference to the FLL (FEI clock mode).
2. This applies when SCTRIM at value (0x80) and SCFTRIM control bit at value (0x0).
3. These typical values listed are with the slow internal reference clock (FEI) using factory trim and DMX32=0.
4. The resulting system clock frequencies should not exceed their maximum specified values. The DCO frequency deviation ( $\Delta f_{dco,t}$ ) over voltage and temperature should be considered.
5. These typical values listed are with the slow internal reference clock (FEI) using factory trim and DMX32=1.
6. The resulting clock frequency must not exceed the maximum specified clock frequency of the device.
7. This specification applies to any time the FLL reference source or reference divider is changed, trim value is changed, DMX32 bit is changed, DRS bits are changed, or changing from FLL disabled (BLPE, BLPI) to FLL enabled (FEI, FEE, FBE, FBI). If a crystal/resonator is being used as the reference, this specification assumes it is already running.
8. Excludes any oscillator currents that are also consuming power while PLL is in operation.
9. This specification was obtained using a NXP developed PCB. PLL jitter is dependent on the noise characteristics of each PCB and results will vary.
10. This specification applies to any time the PLL VCO divider or reference divider is changed, or changing from PLL disabled (BLPE, BLPI) to PLL enabled (PBE, PEE). If a crystal/resonator is being used as the reference, this specification assumes it is already running.

## 3.2.2 IRC48M specifications

Table 20. IRC48M specifications

Symbol	Description	Min.	Typ.	Max.	Unit	Notes
$V_{DD}$	Supply voltage	1.71	—	3.6	V	
$I_{DD48M}$	Supply current	—	520	—	$\mu A$	
$f_{irc48m}$	Internal reference frequency	—	48	—	MHz	
$\Delta f_{irc48m\_ol\_lv}$	Open loop total deviation of IRC48M frequency at low voltage ( $V_{DD}=1.71\text{ V}-1.89\text{ V}$ ) over temperature <ul style="list-style-type: none"> <li>• Regulator disable (USB_CLK_RECOVER_IRC_EN[REG_EN]=0)</li> <li>• Regulator enable (USB_CLK_RECOVER_IRC_EN[REG_EN]=1)</li> </ul>	—	$\pm 0.5$	$\pm 1.0$	$\%f_{irc48m}$	
$\Delta f_{irc48m\_ol\_hv}$	Open loop total deviation of IRC48M frequency at high voltage ( $V_{DD}=1.89\text{ V}-3.6\text{ V}$ ) over temperature <ul style="list-style-type: none"> <li>• Regulator enable (USB_CLK_RECOVER_IRC_EN[REG_EN]=1)</li> </ul>	—	$\pm 0.5$	$\pm 1.0$	$\%f_{irc48m}$	
$\Delta f_{irc48m\_cl}$	Closed loop total deviation of IRC48M frequency over voltage and temperature	—	—	$\pm 0.1$	$\%f_{host}$	1
$J_{cyc\_irc48m}$	Period Jitter (RMS)	—	35	150	ps	
$t_{irc48mst}$	Startup time	—	2	3	$\mu s$	2

1. Closed loop operation of the IRC48M is only feasible for USB device operation; it is not usable for USB host operation. It is enabled by configuring for USB Device, selecting IRC48M as USB clock source, and enabling the clock recover function (USB\_CLK\_RECOVER\_IRC\_CTRL[CLOCK\_RECOVER\_EN]=1, USB\_CLK\_RECOVER\_IRC\_EN[IRC\_EN]=1).
2. IRC48M startup time is defined as the time between clock enablement and clock availability for system use. Enable the clock by one of the following settings:
  - USB\_CLK\_RECOVER\_IRC\_EN[IRC\_EN]=1, or
  - MCG\_C7[OSCSEL]=10, or
  - SIM\_SOPT2[PLLFLSEL]=11

### 3.2.3 Oscillator electrical specifications

#### 3.2.3.1 Oscillator DC electrical specifications

Table 21. Oscillator DC electrical specifications

Symbol	Description	Min.	Typ.	Max.	Unit	Notes
V <sub>DD</sub>	Supply voltage	1.71	—	3.6	V	
I <sub>DDOSC</sub>	Supply current — low-power mode (HGO=0) <ul style="list-style-type: none"> <li>• 32 kHz</li> <li>• 4 MHz</li> <li>• 8 MHz (RANGE=01)</li> <li>• 16 MHz</li> <li>• 24 MHz</li> <li>• 32 MHz</li> </ul>	—	600	—	nA	1
I <sub>DDOSC</sub>	Supply current — high gain mode (HGO=1) <ul style="list-style-type: none"> <li>• 32 kHz</li> <li>• 4 MHz</li> <li>• 8 MHz (RANGE=01)</li> <li>• 16 MHz</li> <li>• 24 MHz</li> <li>• 32 MHz</li> </ul>	—	7.5	—	μA	1
C <sub>x</sub>	EXTAL load capacitance	—	—	—		2, 3
C <sub>y</sub>	XTAL load capacitance	—	—	—		2, 3
R <sub>F</sub>	Feedback resistor — low-frequency, low-power mode (HGO=0)	—	—	—	MΩ	2, 4
	Feedback resistor — low-frequency, high-gain mode (HGO=1)	—	10	—	MΩ	
	Feedback resistor — high-frequency, low-power mode (HGO=0)	—	—	—	MΩ	
	Feedback resistor — high-frequency, high-gain mode (HGO=1)	—	1	—	MΩ	
R <sub>S</sub>	Series resistor — low-frequency, low-power mode (HGO=0)	—	—	—	kΩ	
	Series resistor — low-frequency, high-gain mode (HGO=1)	—	200	—	kΩ	
	Series resistor — high-frequency, low-power mode (HGO=0)	—	—	—	kΩ	
	Series resistor — high-frequency, high-gain mode (HGO=1)	—	—	—	—	

Table continues on the next page...

**Table 21. Oscillator DC electrical specifications (continued)**

Symbol	Description	Min.	Typ.	Max.	Unit	Notes
		—	0	—	k $\Omega$	
$V_{pp}^5$	Peak-to-peak amplitude of oscillation (oscillator mode) — low-frequency, low-power mode (HGO=0)	—	0.6	—	V	
	Peak-to-peak amplitude of oscillation (oscillator mode) — low-frequency, high-gain mode (HGO=1)	—	$V_{DD}$	—	V	
	Peak-to-peak amplitude of oscillation (oscillator mode) — high-frequency, low-power mode (HGO=0)	—	0.6	—	V	
	Peak-to-peak amplitude of oscillation (oscillator mode) — high-frequency, high-gain mode (HGO=1)	—	$V_{DD}$	—	V	

- $V_{DD}=3.3$  V, Temperature =25 °C, Internal capacitance = 20 pf
- See crystal or resonator manufacturer's recommendation
- $C_x, C_y$  can be provided by using either the integrated capacitors or by using external components.
- When low power mode is selected,  $R_f$  is integrated and must not be attached externally.
- The EXTAL and XTAL pins should only be connected to required oscillator components and must not be connected to any other devices.

### 3.2.3.2 Oscillator frequency specifications

**Table 22. Oscillator frequency specifications**

Symbol	Description	Min.	Typ.	Max.	Unit	Notes
$f_{osc\_lo}$	Oscillator crystal or resonator frequency — low-frequency mode (MCG_C2[RANGE]=00)	32	—	40	kHz	
$f_{osc\_hi\_1}$	Oscillator crystal or resonator frequency — high-frequency mode (low range) (MCG_C2[RANGE]=01)	3	—	8	MHz	
$f_{osc\_hi\_2}$	Oscillator crystal or resonator frequency — high frequency mode (high range) (MCG_C2[RANGE]=1x)	8	—	32	MHz	
$t_{dc\_extal}$	Input clock duty cycle (external clock mode)	40	50	60	%	
$t_{cst}$	Crystal startup time — 32 kHz low-frequency, low-power mode (HGO=0)	—	750	—	ms	1, 2
	Crystal startup time — 32 kHz low-frequency, high-gain mode (HGO=1)	—	250	—	ms	
	Crystal startup time — 8 MHz high-frequency (MCG_C2[RANGE]=01), low-power mode (HGO=0)	—	0.6	—	ms	
	Crystal startup time — 8 MHz high-frequency (MCG_C2[RANGE]=01), high-gain mode (HGO=1)	—	1	—	ms	

- Proper PC board layout procedures must be followed to achieve specifications.

- Crystal startup time is defined as the time between the oscillator being enabled and the OSCINIT bit in the MCG\_S register being set.

### NOTE

The 32 kHz oscillator works in low power mode by default and cannot be moved into high power/gain mode.

## 3.2.4 32 kHz oscillator electrical characteristics

### 3.2.4.1 32 kHz oscillator DC electrical specifications

Table 23. 32kHz oscillator DC electrical specifications

Symbol	Description	Min.	Typ.	Max.	Unit
$V_{BAT}$	Supply voltage	1.71	—	3.6	V
$R_F$	Internal feedback resistor	—	100	—	M $\Omega$
$C_{para}$	Parasitical capacitance of EXTAL32 and XTAL32	—	5	7	pF
$V_{pp}$ <sup>1</sup>	Peak-to-peak amplitude of oscillation	—	0.6	—	V

- When a crystal is being used with the 32 kHz oscillator, the EXTAL32 and XTAL32 pins should only be connected to required oscillator components and must not be connected to any other devices.

### 3.2.4.2 32 kHz oscillator frequency specifications

Table 24. 32 kHz oscillator frequency specifications

Symbol	Description	Min.	Typ.	Max.	Unit	Notes
$f_{osc\_lo}$	Oscillator crystal	—	32.768	—	kHz	
$t_{start}$	Crystal start-up time	—	1000	—	ms	1
$f_{ec\_extal32}$	Externally provided input clock frequency	—	32.768	—	kHz	2
$V_{ec\_extal32}$	Externally provided input clock amplitude	700	—	$V_{BAT}$	mV	2, 3

- Proper PC board layout procedures must be followed to achieve specifications.
- This specification is for an externally supplied clock driven to EXTAL32 and does not apply to any other clock input. The oscillator remains enabled and XTAL32 must be left unconnected.
- The parameter specified is a peak-to-peak value and  $V_{IH}$  and  $V_{IL}$  specifications do not apply. The voltage of the applied clock must be within the range of  $V_{SS}$  to  $V_{BAT}$ .

## 3.3 Memories and memory interfaces

### 3.3.1 QuadSPI AC specifications

- All data is based on a negative edge data launch from the device and a positive edge data capture, as shown in the timing diagrams in this section.
- Measurements are with a load of 15 pf (1.8 V) and 35 pf (3 V) on output pins. Input slew: 1 ns
- Timings assume a setting of 0x0000\_000x for QuadSPI \_SMPR register (see the reference manual for details).

The following table lists the QuadSPI delay chain read/write settings. Refer the device reference manual for register and bit descriptions.

**Table 25. QuadSPI delay chain read/write settings**

Mode	QuadSPI registers				Notes
	QuadSPI_MCR[DQ S_EN]	QuadSPI_SOCCR[SOCCFG]	QuadSPI_MCR[SC LKCFG]	QuadSPI_FLSHCR[TDH]	
SDR	Yes	3Fh	5	No	Delay of 63 buffer and 64 mux
DDR	Yes	3Fh	1	2	Delay of 63 buffer and 64 mux
Hyperflash	RDS driven from Flash	0h	No	2	Delay of 1 mux

#### SDR mode

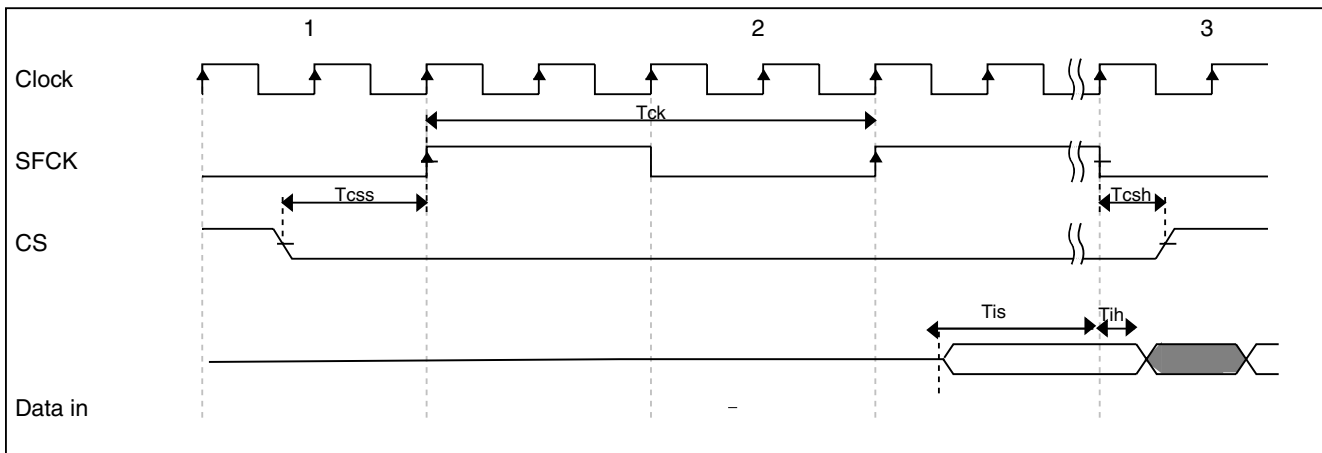

**Figure 11. QuadSPI input timing (SDR mode) diagram**

#### NOTE

- The below timing values are with default settings for sampling registers like QuadSPI\_SMPR.

- A negative time indicates the actual capture edge inside the device is earlier than clock appearing at pad.
- The below timing are for a load of 15 pf (1.8 V) and 35 pf (3 V) or output pads
- All board delays need to be added appropriately
- Input hold time being negative does not have any implication or max achievable frequency

**Table 26. QuadSPI input timing (SDR mode) specifications**

Symbol	Parameter	Value		Unit
		Min	Max	
$T_{is}$	Setup time for incoming data	4	-	ns
$T_{ih}$	Hold time requirement for incoming data	1.5	-	ns

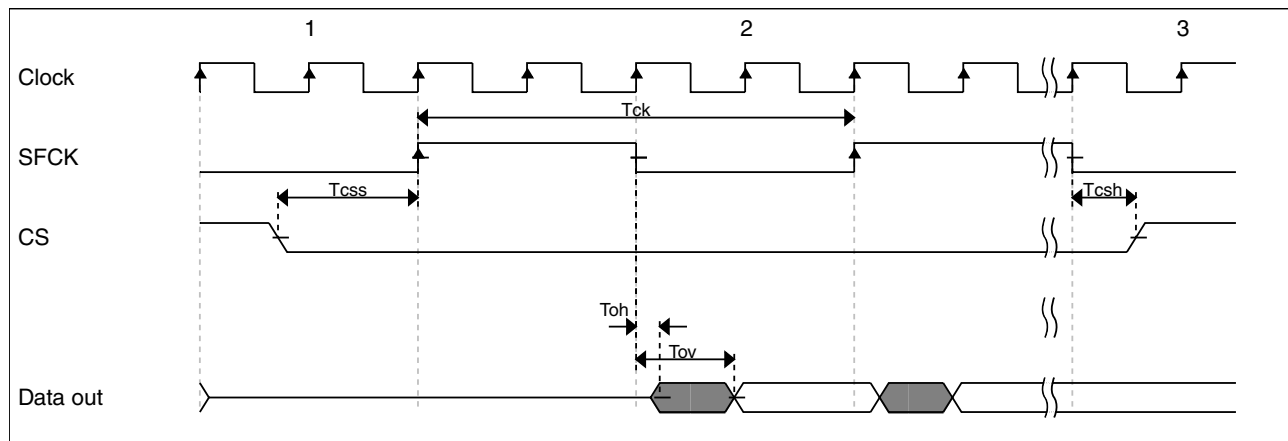
**Figure 12. QuadSPI output timing (SDR mode) diagram****Table 27. QuadSPI output timing (SDR mode) specifications**

Symbol	Parameter	Value		Unit
		Min	Max	
$T_{ov}$	Output Data Valid	-	2.8	ns
$T_{oh}$	Output Data Hold	-1.4	-	ns
$T_{ck}$	SCK clock period	-	100	MHz
$T_{css}$	Chip select output setup time	2	-	ns
$T_{csh}$	Chip select output hold time	-1	-	ns

**NOTE**

For any frequency setup and hold specifications of the memory should be met.

## DDR Mode

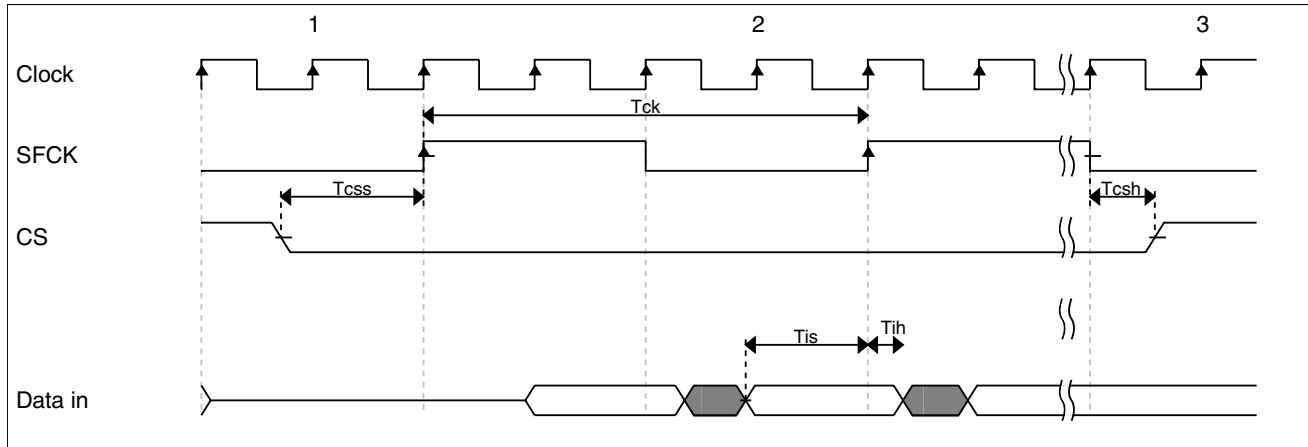

**Figure 13. QuadSPI input timing (DDR mode) diagram**

### NOTE

- Numbers are for a load of 15 pf (1.8 V) and 35 pf (3 V)
- The numbers are for setting of hold condition in register QuadSPI\_SMPR[DDRSNP]

**Table 28. QuadSPI input timing (DDR mode) specifications**

Symbol	Parameter	Value		Unit
		Min	Max	
$T_{is}$	Setup time for incoming data	4 (Without learning)	-	ns
		1 (With learning)		
$T_{ih}$	Hold time requirement for incoming data	1.5	-	ns

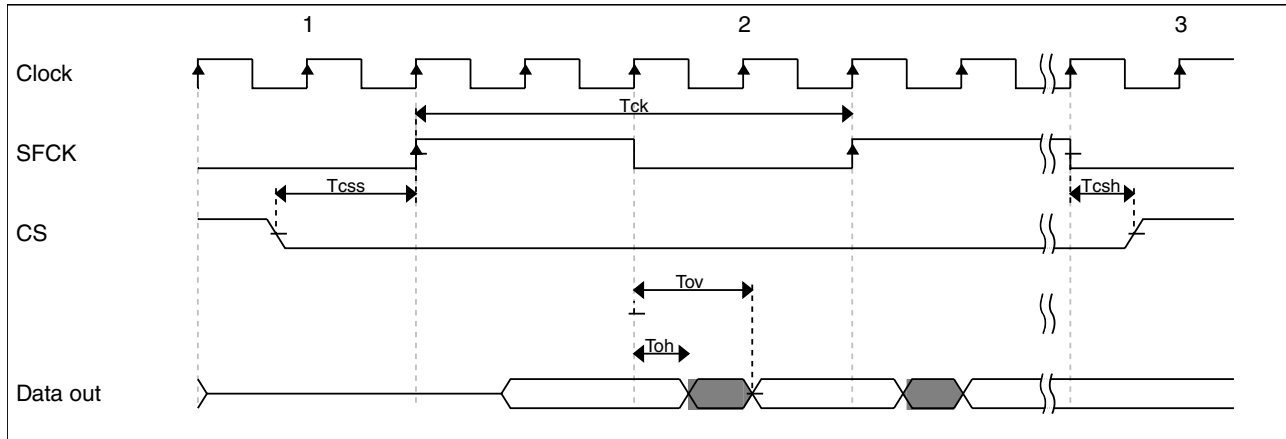

Figure 14. QuadSPI output timing (DDR mode) diagram

Table 29. QuadSPI output timing (DDR mode) specifications

Symbol	Parameter	Value		Unit
		Min	Max	
$T_{ov}$	Output Data Valid	-	4.5	ns
$T_{oh}$	Output Data Hold	1.5	-	ns
$T_{ck}$	SCK clock period	-	75 (with learning)	MHz
		-	45 (without learning)	
$T_{css}$	Chip select output setup time	2	-	Clk(sck)
$T_{csh}$	Chip select output hold time	-1	-	Clk(sck)

## Hyperflash mode

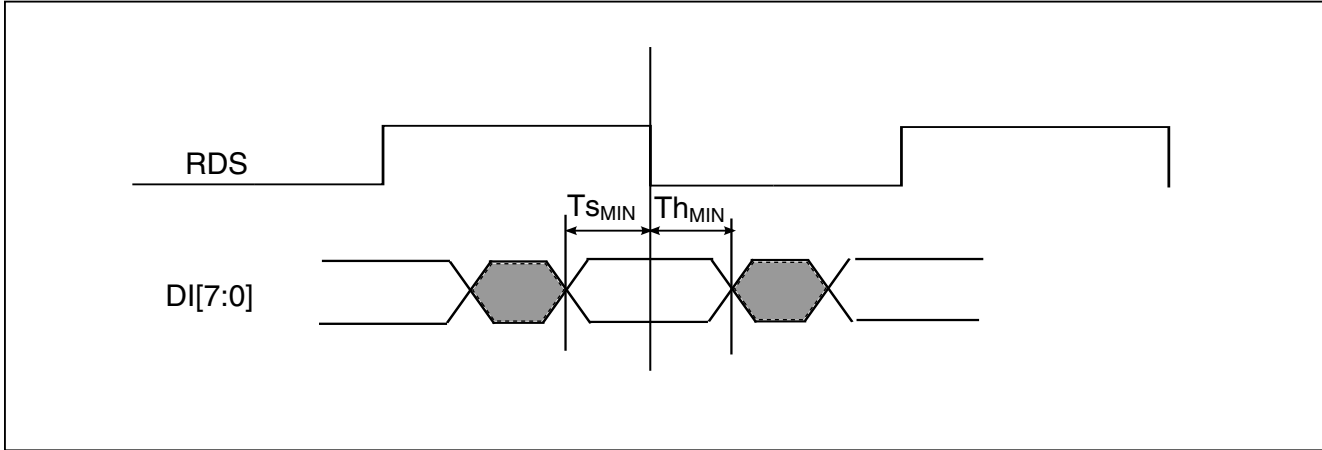

Figure 15. QuadSPI input timing (Hyperflash mode) diagram

Table 30. QuadSPI input timing (Hyperflash mode) specifications

Symbol	Parameter	Value		Unit
		Min	Max	
$T_{S_{MIN}}$	Setup time for incoming data	2	-	ns
$T_{H_{MIN}}$	Hold time requirement for incoming data	2	-	ns

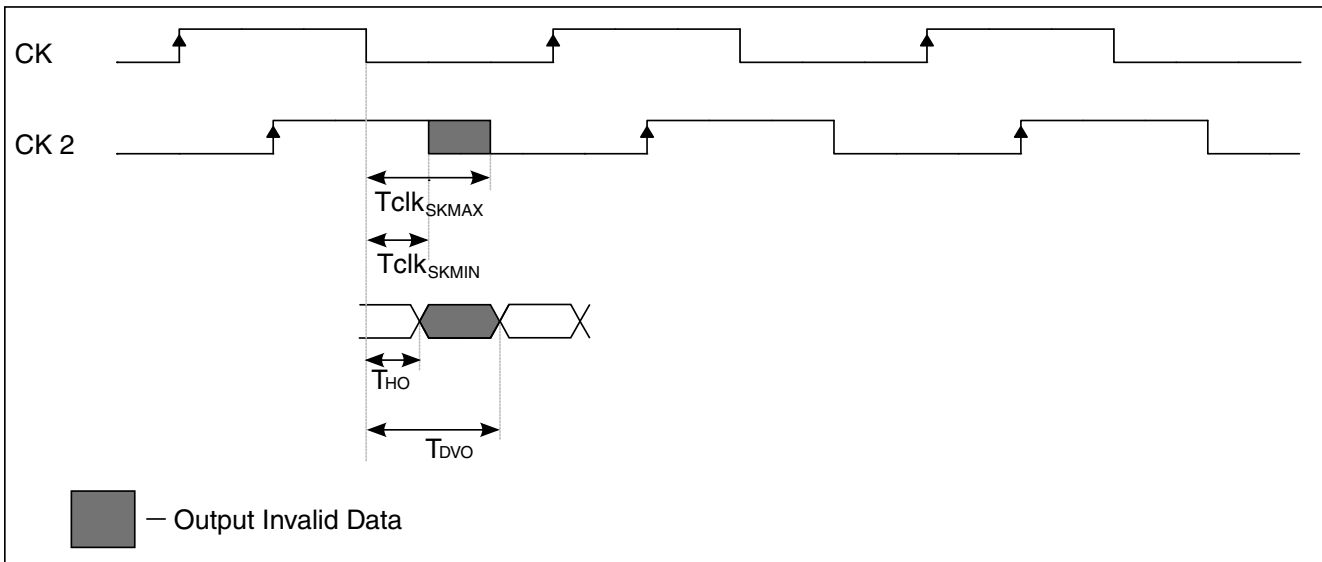

Figure 16. QuadSPI output timing (Hyperflash mode) diagram

Table 31. QuadSPI output timing (Hyperflash mode) specifications

Symbol	Parameter	Value		Unit
		Min	Max	
$T_{dV_{MAX}}$	Output Data Valid	-	4.3	ns

Table continues on the next page...

**Table 31. QuadSPI output timing (Hyperflash mode) specifications (continued)**

Symbol	Parameter	Value		Unit
		Min	Max	
T <sub>ho</sub>	Output Data Hold	1.3	-	ns
T <sub>clk<sub>SKMAX</sub></sub>	Ck to Ck2 skew max	-	T/4 + 0.5	ns
T <sub>clk<sub>SKMIN</sub></sub>	Ck to Ck2 skew min	T/4 - 0.5	-	ns

**NOTE**

Maximum clock frequency = 75 MHz.

**3.3.2 Flash electrical specifications**

This section describes the electrical characteristics of the flash memory module.

**3.3.2.1 Flash timing specifications — program and erase**

The following specifications represent the amount of time the internal charge pumps are active and do not include command overhead.

**Table 32. NVM program/erase timing specifications**

Symbol	Description	Min.	Typ.	Max.	Unit	Notes
t <sub>hvp<sub>pgm8</sub></sub>	Program Phrase high-voltage time	—	7.5	18	μs	
t <sub>hversscr</sub>	Erase Flash Sector high-voltage time	—	13	113	ms	1
t <sub>hversblk512k</sub>	Erase Flash Block high-voltage time for 512 KB	—	413	3616	ms	1

1. Maximum time based on expectations at cycling end-of-life.

**3.3.2.2 Flash timing specifications — commands****Table 33. Flash command timing specifications**

Symbol	Description	Min.	Typ.	Max.	Unit	Notes
t <sub>rd1blk512k</sub>	Read 1s Block execution time • 512 KB program flash	—	—	1.8	ms	
t <sub>rd1sec4k</sub>	Read 1s Section execution time (4 KB flash)	—	—	100	μs	1
t <sub>pgmchk</sub>	Program Check execution time	—	—	95	μs	1
t <sub>rdsrc</sub>	Read Resource execution time	—	—	40	μs	1
t <sub>pgm8</sub>	Program Phrase execution time	—	90	150	μs	
	Erase Flash Block execution time					2

Table continues on the next page...

**Table 33. Flash command timing specifications (continued)**

Symbol	Description	Min.	Typ.	Max.	Unit	Notes
$t_{ersblk512k}$	• 512 KB program flash	—	435	3700	ms	
$t_{ersscr}$	Erase Flash Sector execution time	—	15	115	ms	2
$t_{pgmsec1k}$	Program Section execution time (1 KB flash)	—	5	—	ms	
$t_{rd1all}$	Read 1s All Blocks execution time	—	—	6.7	ms	
$t_{rdonce}$	Read Once execution time	—	—	30	$\mu$ s	1
$t_{pgmonce}$	Program Once execution time	—	90	—	$\mu$ s	
$t_{ersall}$	Erase All Blocks execution time	—	1750	14,800	ms	2
$t_{vfykey}$	Verify Backdoor Access Key execution time	—	—	30	$\mu$ s	1
$t_{ersallu}$	Erase All Blocks Unsecure execution time	—	1750	14,800	ms	2
	Swap Control execution time					
$t_{swapx01}$	• control code 0x01	—	200	—	$\mu$ s	
$t_{swapx02}$	• control code 0x02	—	90	150	$\mu$ s	
$t_{swapx04}$	• control code 0x04	—	90	150	$\mu$ s	
$t_{swapx08}$	• control code 0x08	—	—	30	$\mu$ s	
$t_{swapx10}$	• control code 0x10	—	90	150	$\mu$ s	

1. Assumes 25MHz or greater flash clock frequency.
2. Maximum times for erase parameters based on expectations at cycling end-of-life.

### 3.3.2.3 Flash high voltage current behaviors

**Table 34. Flash high voltage current behaviors**

Symbol	Description	Min.	Typ.	Max.	Unit
$I_{DD\_PGM}$	Average current adder during high voltage flash programming operation	—	3.5	7.5	mA
$I_{DD\_ERS}$	Average current adder during high voltage flash erase operation	—	1.5	4.0	mA

### 3.3.2.4 Reliability specifications

**Table 35. NVM reliability specifications**

Symbol	Description	Min.	Typ. <sup>1</sup>	Max.	Unit	Notes
Program Flash						
$t_{nvmretp10k}$	Data retention after up to 10 K cycles	5	50	—	years	
$t_{nvmretp1k}$	Data retention after up to 1 K cycles	20	100	—	years	
$\eta_{nvmcycp}$	Cycling endurance	10 K	50 K	—	cycles	2

1. Typical data retention values are based on measured response accelerated at high temperature and derated to a constant 25°C use profile. Engineering Bulletin EB618 does not apply to this technology. Typical endurance defined in Engineering Bulletin EB619.
2. Cycling endurance represents number of program/erase cycles at  $-40^{\circ}\text{C} \leq T_j \leq 125^{\circ}\text{C}$ .

### 3.3.3 Flexbus switching specifications

All processor bus timings are synchronous; input setup/hold and output delay are given in respect to the rising edge of a reference clock, FB\_CLK. The FB\_CLK frequency may be the same as the internal system bus frequency or an integer divider of that frequency.

The following timing numbers indicate when data is latched or driven onto the external bus, relative to the Flexbus output clock (FB\_CLK). All other timing relationships can be derived from these values.

**Table 36. Flexbus limited voltage range switching specifications**

Num	Description	Min.	Max.	Unit	Notes
	Operating voltage	2.7	3.6	V	
	Frequency of operation	—	FB_CLK	MHz	
FB1	Clock period	1/FB_CLK	—	ns	
FB2	Address, data, and control output valid	—	11.8	ns	
FB3	Address, data, and control output hold	1.0	—	ns	1
FB4	Data and $\overline{\text{FB\_TA}}$ input setup	11.9	—	ns	
FB5	Data and $\overline{\text{FB\_TA}}$ input hold	0.0	—	ns	2

1. Specification is valid for all FB\_AD[31:0],  $\overline{\text{FB\_BE/BWE}n}$ ,  $\overline{\text{FB\_CS}n}$ , FB\_OE, FB\_R/W, FB\_TBST, FB\_TSIZE[1:0], FB\_ALE, and FB\_TS.
2. Specification is valid for all FB\_AD[31:0] and  $\overline{\text{FB\_TA}}$ .

**Table 37. Flexbus full voltage range switching specifications**

Num	Description	Min.	Max.	Unit	Notes
	Operating voltage	1.71	3.6	V	
	Frequency of operation	—	FB_CLK	MHz	
FB1	Clock period	1/FB_CLK	—	ns	
FB2	Address, data, and control output valid	—	12.6	ns	
FB3	Address, data, and control output hold	1.0	—	ns	1
FB4	Data and $\overline{\text{FB\_TA}}$ input setup	12.5	—	ns	
FB5	Data and $\overline{\text{FB\_TA}}$ input hold	0	—	ns	2

1. Specification is valid for all FB\_AD[31:0],  $\overline{\text{FB\_BE/BWE}n}$ ,  $\overline{\text{FB\_CS}n}$ , FB\_OE, FB\_R/W, FB\_TBST, FB\_TSIZE[1:0], FB\_ALE, and FB\_TS.
2. Specification is valid for all FB\_AD[31:0] and  $\overline{\text{FB\_TA}}$ .

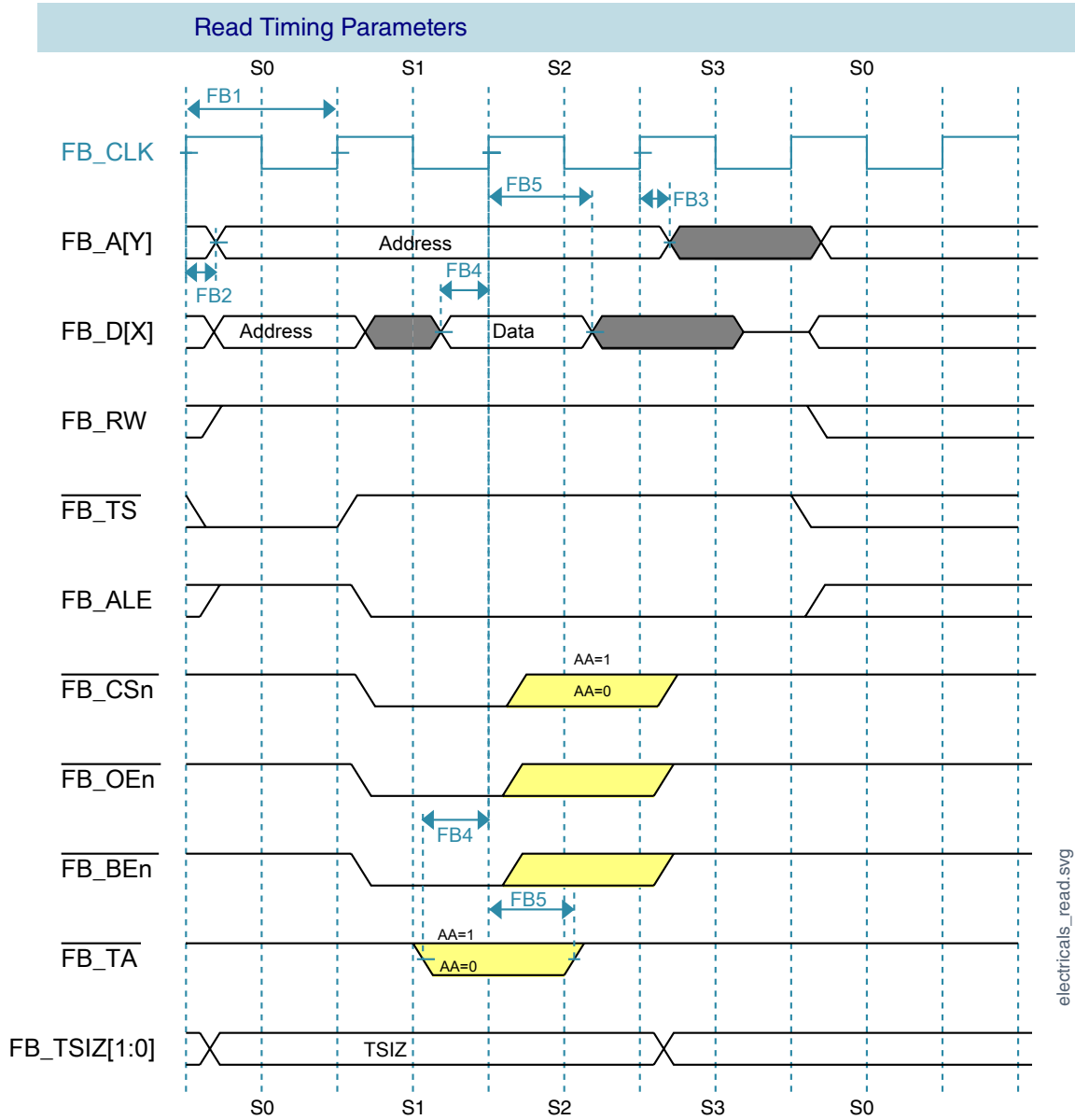
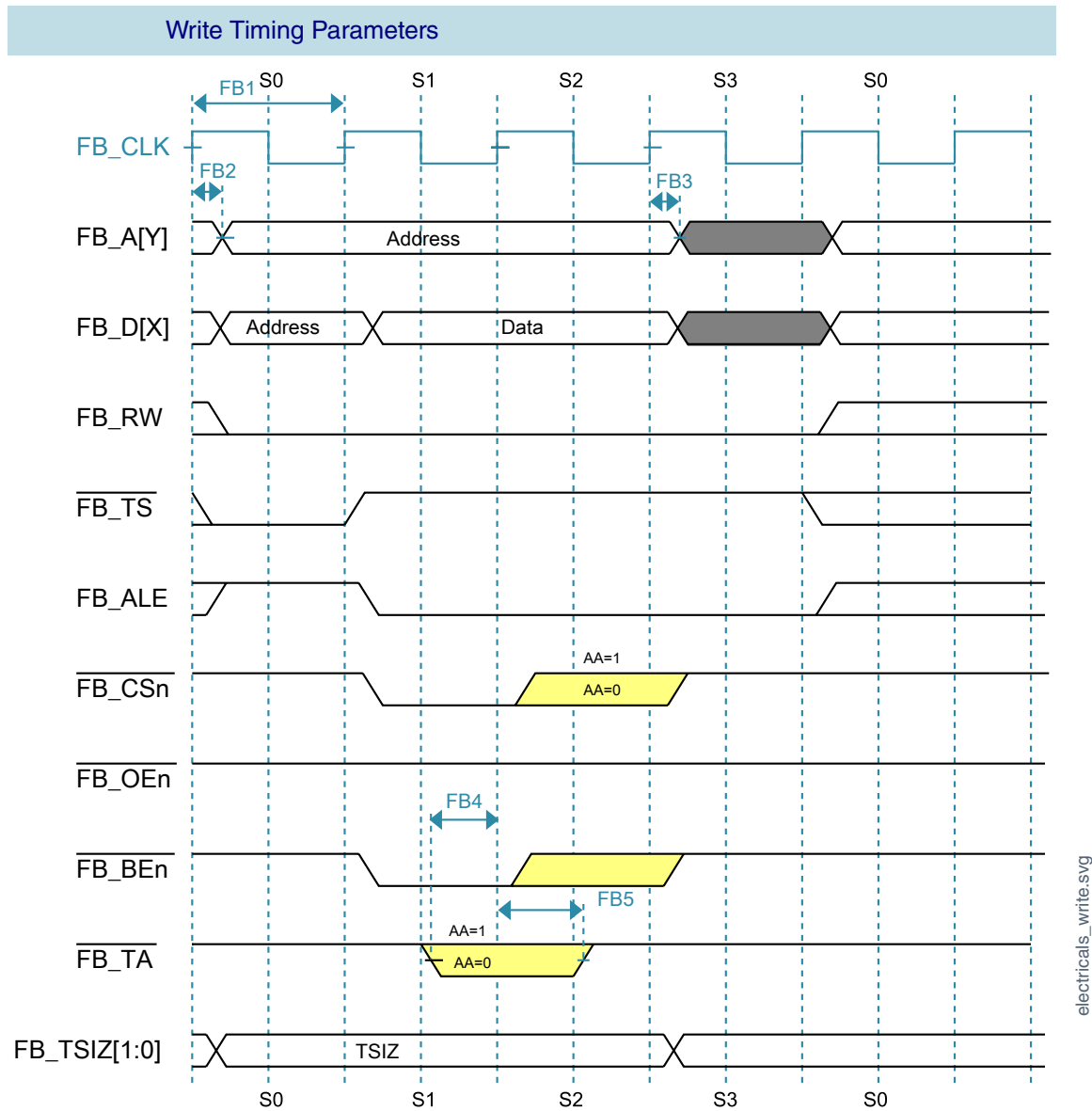

Figure 17. FlexBus read timing diagram

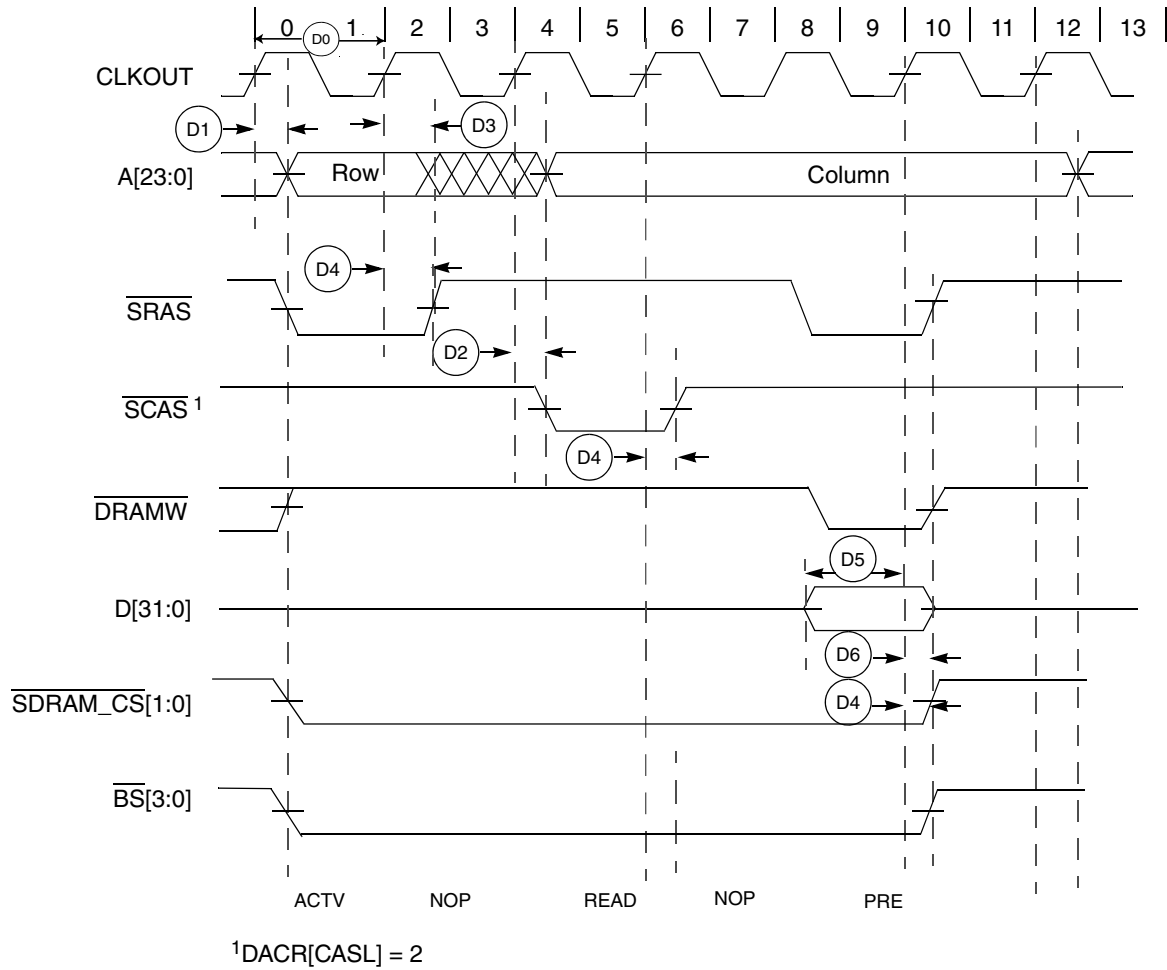

**Figure 18. FlexBus write timing diagram**

### 3.3.4 SDRAM controller specifications

Following figure shows SDRAM read cycle.

## Peripheral operating requirements and behaviors



**Figure 19. SDRAM read timing diagram**

**Table 38. SDRAM Timing (Full voltage range)**

NUM	Characteristic <sup>1</sup>	Symbol	Min	Max	Unit
	Operating voltage	1.71	3.6	V	
	Frequency of operation	—	CLKOUT	MHz	
D0	Clock period	1/CLKOUT	—	ns	2
D1	CLKOUT high to SDRAM address valid	t <sub>CHDAV</sub>	-	11.2	ns
D2	CLKOUT high to SDRAM control valid	t <sub>CHDCV</sub>		11.1	ns
D3	CLKOUT high to SDRAM address invalid	t <sub>CHDAI</sub>	1.0	-	ns
D4	CLKOUT high to SDRAM control invalid	t <sub>CHDCI</sub>	1.0	-	ns
D5	SDRAM data valid to CLKOUT high	t <sub>DDVCH</sub>	12.0	-	ns
D6	CLKOUT high to SDRAM data invalid	t <sub>CHDDI</sub>	1.0	-	ns
D7 <sup>3</sup>	CLKOUT high to SDRAM data valid	t <sub>CHDDVW</sub>	-	12.0	ns
D8 <sup>3</sup>	CLKOUT high to SDRAM data invalid	t <sub>CHDDIW</sub>	1.0	-	ns

1. All timing specifications are based on taking into account, a 25 pF load on the SDRAM output pins.

2. CLKOUT is same as FB\_CLK, maximum frequency can be 75 MHz

3. D7 and D8 are for write cycles only.

**Table 39. SDRAM Timing (Limited voltage range)**

NUM	Characteristic <sup>1</sup>	Symbol	Min	Max	Unit
	Operating voltage	2.7	3.6	V	
	Frequency of operation	—	CLKOUT	MHz	
D0	Clock period	1/CLKOUT	—	ns	<sup>2</sup>
D1	CLKOUT high to SDRAM address valid	$t_{\text{CHDAV}}$	-	11.1	ns
D2	CLKOUT high to SDRAM control valid	$t_{\text{CHDCV}}$		11.1	ns
D3	CLKOUT high to SDRAM address invalid	$t_{\text{CHDAI}}$	1.0	-	ns
D4	CLKOUT high to SDRAM control invalid	$t_{\text{CHDCI}}$	1.0	-	ns
D5	SDRAM data valid to CLKOUT high	$t_{\text{DDVCH}}$	11.3	-	ns
D6	CLKOUT high to SDRAM data invalid	$t_{\text{CHDDI}}$	1.0	-	ns
D7 <sup>3</sup>	CLKOUT high to SDRAM data valid	$t_{\text{CHDDVW}}$	-	11.1	ns
D8 <sup>3</sup>	CLKOUT high to SDRAM data invalid	$t_{\text{CHDDIW}}$	1.0	-	ns

1. All timing specifications are based on taking into account, a 25 pF load on the SDRAM output pins.
2. CLKOUT is same as FB\_CLK, maximum frequency can be 75 MHz
3. D7 and D8 are for write cycles only.

Following figure shows an SDRAM write cycle.

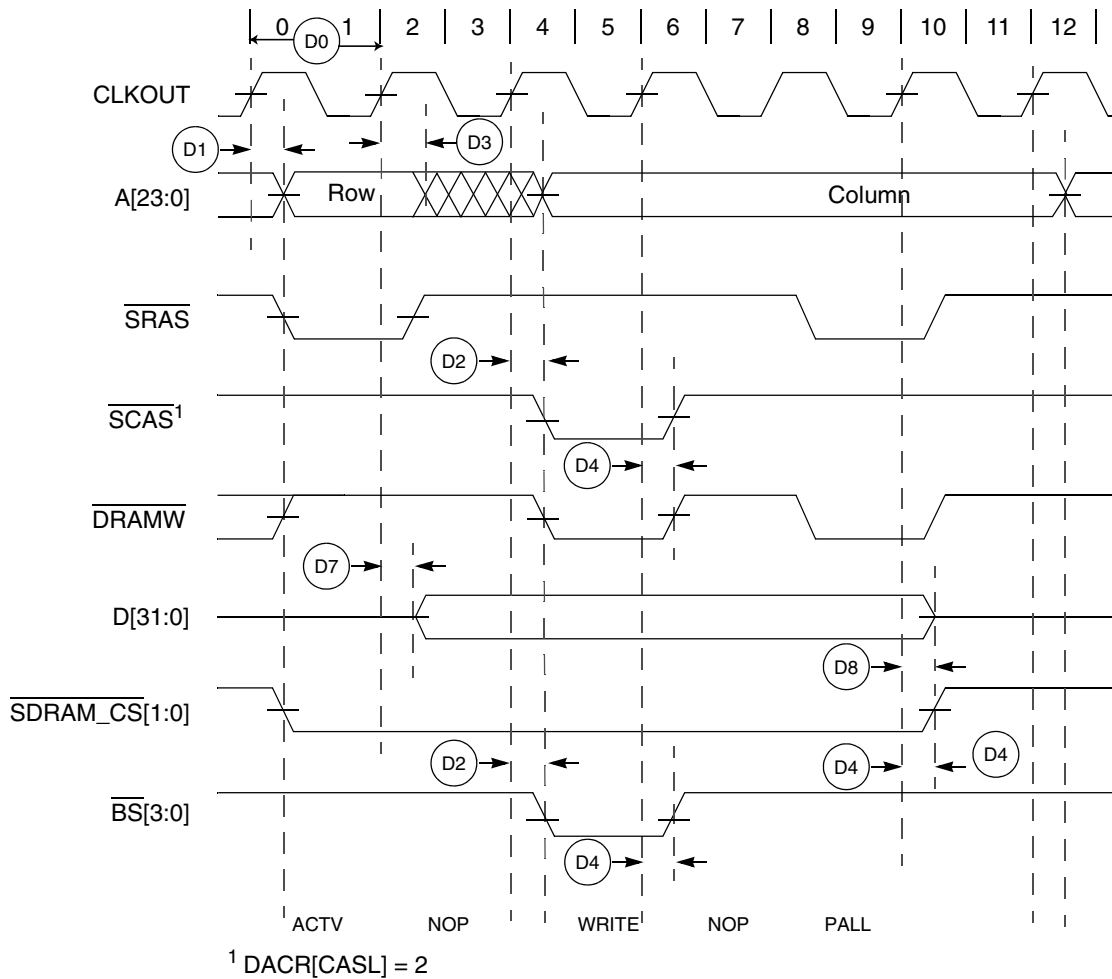

**Figure 20. SDRAM write timing diagram**

## 3.4 Analog

### 3.4.1 ADC electrical specifications

The 16-bit accuracy specifications listed in [Table 40](#) and [Table 41](#) are achievable on the differential pins ADCx\_DP0, ADCx\_DM0.

All other ADC channels meet the 13-bit differential/12-bit single-ended accuracy specifications.

### 3.4.1.1 16-bit ADC operating conditions

Table 40. 16-bit ADC operating conditions

Symbol	Description	Conditions	Min.	Typ. <sup>1</sup>	Max.	Unit	Notes
V <sub>DDA</sub>	Supply voltage	Absolute	1.71	—	3.6	V	
ΔV <sub>DDA</sub>	Supply voltage	Delta to V <sub>DD</sub> (V <sub>DD</sub> – V <sub>DDA</sub> )	-100	0	+100	mV	2
ΔV <sub>SSA</sub>	Ground voltage	Delta to V <sub>SS</sub> (V <sub>SS</sub> – V <sub>SSA</sub> )	-100	0	+100	mV	2
V <sub>REFH</sub>	ADC reference voltage high		1.13	V <sub>DDA</sub>	V <sub>DDA</sub>	V	
V <sub>REFL</sub>	ADC reference voltage low		V <sub>SSA</sub>	V <sub>SSA</sub>	V <sub>SSA</sub>	V	
V <sub>ADIN</sub>	Input voltage	<ul style="list-style-type: none"> <li>16-bit differential mode</li> <li>All other modes</li> </ul>	V <sub>REFL</sub> V <sub>REFL</sub>	— —	31/32 × V <sub>REFH</sub> V <sub>REFH</sub>	V	
C <sub>ADIN</sub>	Input capacitance	<ul style="list-style-type: none"> <li>16-bit mode</li> <li>8-bit / 10-bit / 12-bit modes</li> </ul>	— —	8 4	10 5	pF	
R <sub>ADIN</sub>	Input series resistance		—	2	5	kΩ	
R <sub>AS</sub>	Analog source resistance (external)	13-bit / 12-bit modes f <sub>ADCK</sub> < 4 MHz	—	—	5	kΩ	3
f <sub>ADCK</sub>	ADC conversion clock frequency	≤ 13-bit mode	1.0	—	18.0	MHz	4
f <sub>ADCK</sub>	ADC conversion clock frequency	16-bit mode	2.0	—	12.0	MHz	4
C <sub>rate</sub>	ADC conversion rate	≤ 13-bit modes No ADC hardware averaging Continuous conversions enabled, subsequent conversion time	20.000	—	818.330	kS/s	5
C <sub>rate</sub>	ADC conversion rate	16-bit mode No ADC hardware averaging Continuous conversions enabled, subsequent conversion time	37.037	—	461.467	kS/s	5

1. Typical values assume V<sub>DDA</sub> = 3.0 V, Temp = 25 °C, f<sub>ADCK</sub> = 1.0 MHz, unless otherwise stated. Typical values are for reference only, and are not tested in production.
2. DC potential difference.
3. This resistance is external to MCU. To achieve the best results, the analog source resistance must be kept as low as possible. The results in this data sheet were derived from a system that had < 8 Ω analog source resistance. The R<sub>AS</sub>/C<sub>AS</sub> time constant should be kept to < 1 ns.
4. To use the maximum ADC conversion clock frequency, CFG2[ADHSC] must be set and CFG1[ADLPC] must be clear.
5. For guidelines and examples of conversion rate calculation, download the [ADC calculator tool](#).

## Peripheral operating requirements and behaviors

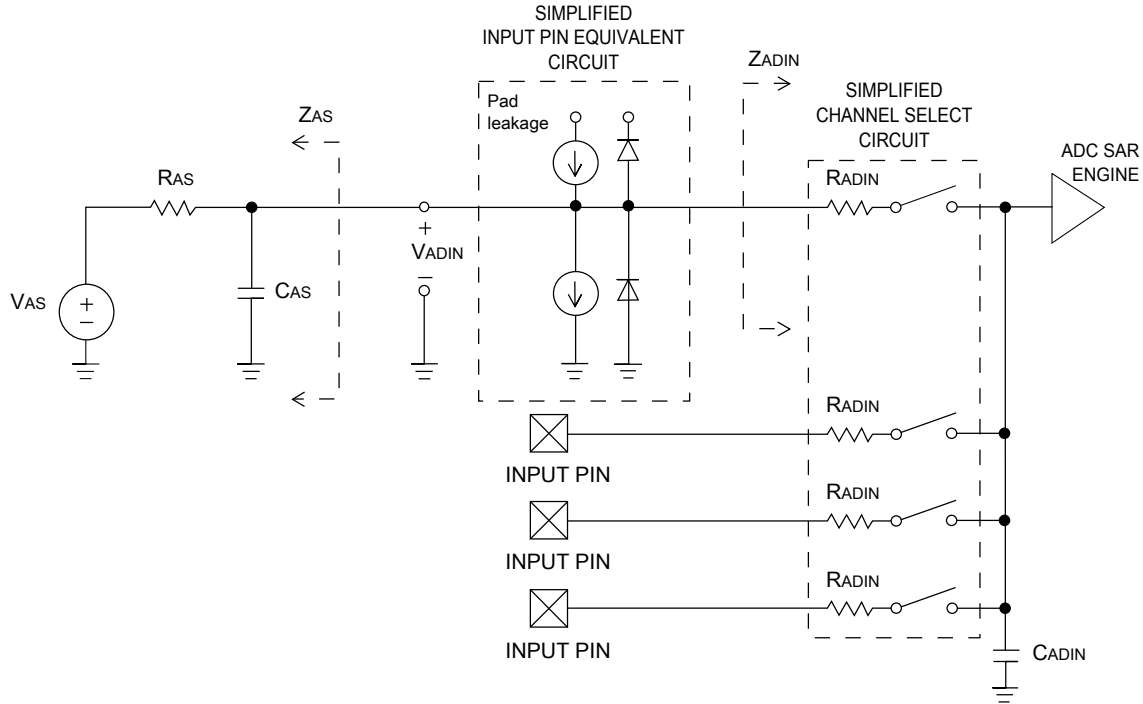

Figure 21. ADC input impedance equivalency diagram

### 3.4.1.2 16-bit ADC electrical characteristics

Table 41. 16-bit ADC characteristics ( $V_{REFH} = V_{DDA}$ ,  $V_{REFL} = V_{SSA}$ )

Symbol	Description	Conditions <sup>1</sup>	Min.	Typ. <sup>2</sup>	Max.	Unit	Notes
$I_{DDA\_ADC}$	Supply current		0.215	—	1.7	mA	3
$f_{ADACK}$	ADC asynchronous clock source	<ul style="list-style-type: none"> <li>• ADLPC = 1, ADHSC = 0</li> <li>• ADLPC = 1, ADHSC = 1</li> <li>• ADLPC = 0, ADHSC = 0</li> <li>• ADLPC = 0, ADHSC = 1</li> </ul>	1.2	2.4	3.9	MHz	$t_{ADACK} = 1/f_{ADACK}$
			2.4	4.0	6.1	MHz	
			3.0	5.2	7.3	MHz	
			4.4	6.2	9.5	MHz	
	Sample Time	See Reference Manual chapter for sample times					
TUE	Total unadjusted error	<ul style="list-style-type: none"> <li>• 12-bit modes</li> <li>• &lt;12-bit modes</li> </ul>	—	±4	±6.8	LSB <sup>4</sup>	5
DNL	Differential non-linearity	<ul style="list-style-type: none"> <li>• 12-bit modes</li> <li>• &lt;12-bit modes</li> </ul>	—	±0.7	-1.1 to +1.9	LSB <sup>4</sup>	5
INL	Integral non-linearity	<ul style="list-style-type: none"> <li>• 12-bit modes</li> </ul>	—	±1.0	-2.7 to +1.9	LSB <sup>4</sup>	5

Table continues on the next page...

**Table 41. 16-bit ADC characteristics ( $V_{REFH} = V_{DDA}$ ,  $V_{REFL} = V_{SSA}$ ) (continued)**

Symbol	Description	Conditions <sup>1</sup>	Min.	Typ. <sup>2</sup>	Max.	Unit	Notes
		<ul style="list-style-type: none"> <li>&lt;12-bit modes</li> </ul>	—	±0.5	-0.7 to +0.5		
$E_{FS}$	Full-scale error	<ul style="list-style-type: none"> <li>12-bit modes</li> <li>&lt;12-bit modes</li> </ul>	—	-4	-5.4	LSB <sup>4</sup>	$V_{ADIN} = V_{DDA}$ <sup>5</sup>
$E_Q$	Quantization error	<ul style="list-style-type: none"> <li>16-bit modes</li> <li>≤13-bit modes</li> </ul>	—	-1 to 0	—	LSB <sup>4</sup>	
ENOB	Effective number of bits	16-bit differential mode					6
		<ul style="list-style-type: none"> <li>Avg = 32</li> </ul>	12.8	14.5	—	bits	
		<ul style="list-style-type: none"> <li>Avg = 4</li> </ul>	11.9	13.8	—	bits	
		16-bit single-ended mode					
<ul style="list-style-type: none"> <li>Avg = 32</li> <li>Avg = 4</li> </ul>	12.2	13.9	—	bits			
			11.4	13.1	—	bits	
SINAD	Signal-to-noise plus distortion	See ENOB	6.02 × ENOB + 1.76			dB	
THD	Total harmonic distortion	16-bit differential mode				dB	7
		<ul style="list-style-type: none"> <li>Avg = 32</li> </ul>	—	-94	—	dB	
		16-bit single-ended mode					
		<ul style="list-style-type: none"> <li>Avg = 32</li> </ul>	—	-85	—		
SFDR	Spurious free dynamic range	16-bit differential mode				dB	7
		<ul style="list-style-type: none"> <li>Avg = 32</li> </ul>	82	95	—	dB	
		16-bit single-ended mode					
		<ul style="list-style-type: none"> <li>Avg = 32</li> </ul>	78	90			
$E_{IL}$	Input leakage error		$I_{in} \times R_{AS}$			mV	$I_{in}$ = leakage current (refer to the MCU's voltage and current operating ratings)
	Temp sensor slope	Across the full temperature range of the device	1.55	1.62	1.69	mV/°C	8
$V_{TEMP25}$	Temp sensor voltage	25 °C	706	716	726	mV	8

- All accuracy numbers assume the ADC is calibrated with  $V_{REFH} = V_{DDA}$
- Typical values assume  $V_{DDA} = 3.0$  V, Temp = 25 °C,  $f_{ADCK} = 2.0$  MHz unless otherwise stated. Typical values are for reference only and are not tested in production.
- The ADC supply current depends on the ADC conversion clock speed, conversion rate and ADC\_CFG1[ADLPC] (low power). For lowest power operation, ADC\_CFG1[ADLPC] must be set, the ADC\_CFG2[ADHSC] bit must be clear with 1 MHz ADC conversion clock speed.

## Peripheral operating requirements and behaviors

4.  $1 \text{ LSB} = (V_{\text{REFH}} - V_{\text{REFL}})/2^N$
5. ADC conversion clock < 16 MHz, Max hardware averaging (AVGE = %1, AVGS = %11)
6. Input data is 100 Hz sine wave. ADC conversion clock < 12 MHz.
7. Input data is 1 kHz sine wave. ADC conversion clock < 12 MHz.
8. ADC conversion clock < 3 MHz

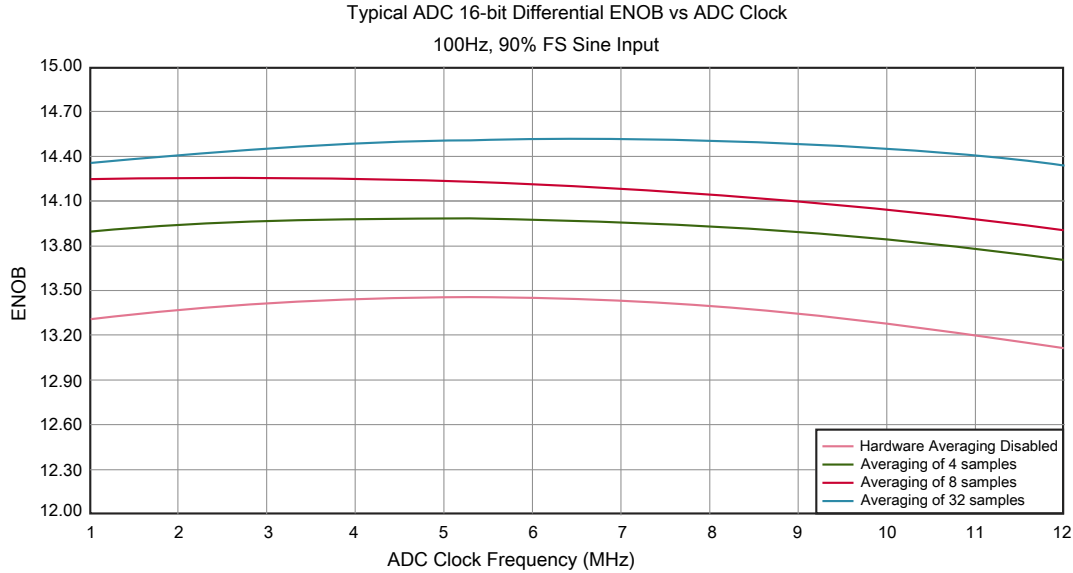

**Figure 22. Typical ENOB vs. ADC\_CLK for 16-bit differential mode**

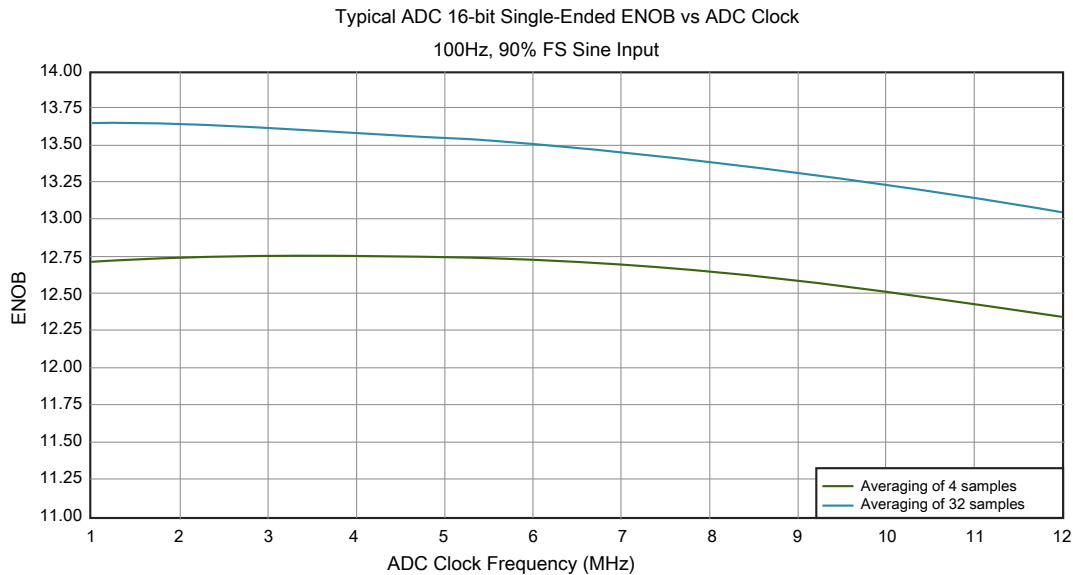

**Figure 23. Typical ENOB vs. ADC\_CLK for 16-bit single-ended mode**

### 3.4.2 CMP and 6-bit DAC electrical specifications

**Table 42. Comparator and 6-bit DAC electrical specifications**

Symbol	Description	Min.	Typ.	Max.	Unit
$V_{DD}$	Supply voltage	1.71	—	3.6	V
$I_{DDHS}$	Supply current, High-speed mode (EN=1, PMODE=1)	—	—	200	$\mu$ A
$I_{DDL S}$	Supply current, low-speed mode (EN=1, PMODE=0)	—	—	20	$\mu$ A
$V_{AIN}$	Analog input voltage	$V_{SS} - 0.3$	—	$V_{DD}$	V
$V_{AIO}$	Analog input offset voltage	—	—	20	mV
$V_H$	Analog comparator hysteresis <sup>1</sup> <ul style="list-style-type: none"> <li>• CR0[HYSTCTR] = 00</li> <li>• CR0[HYSTCTR] = 01</li> <li>• CR0[HYSTCTR] = 10</li> <li>• CR0[HYSTCTR] = 11</li> </ul>	—	5	—	mV
		—	10	—	mV
		—	20	—	mV
		—	30	—	mV
$V_{CMPOh}$	Output high	$V_{DD} - 0.5$	—	—	V
$V_{CMPOl}$	Output low	—	—	0.5	V
$t_{DHS}$	Propagation delay, high-speed mode (EN=1, PMODE=1)	20	50	200	ns
$t_{DLS}$	Propagation delay, low-speed mode (EN=1, PMODE=0)	80	250	600	ns
	Analog comparator initialization delay <sup>2</sup>	—	—	40	$\mu$ s
$I_{DAC6b}$	6-bit DAC current adder (enabled)	—	7	—	$\mu$ A
INL	6-bit DAC integral non-linearity	-0.5	—	0.5	LSB <sup>3</sup>
DNL	6-bit DAC differential non-linearity	-0.3	—	0.3	LSB

1. Typical hysteresis is measured with input voltage range limited to 0.6 to  $V_{DD}-0.6$  V.
2. Comparator initialization delay is defined as the time between software writes to change control inputs (Writes to CMP\_DACCR[DACEN], CMP\_DACCR[VRSEL], CMP\_DACCR[VOSEL], CMP\_MUXCR[PSEL], and CMP\_MUXCR[MSEL]) and the comparator output settling to a stable level.
3. 1 LSB =  $V_{reference}/64$

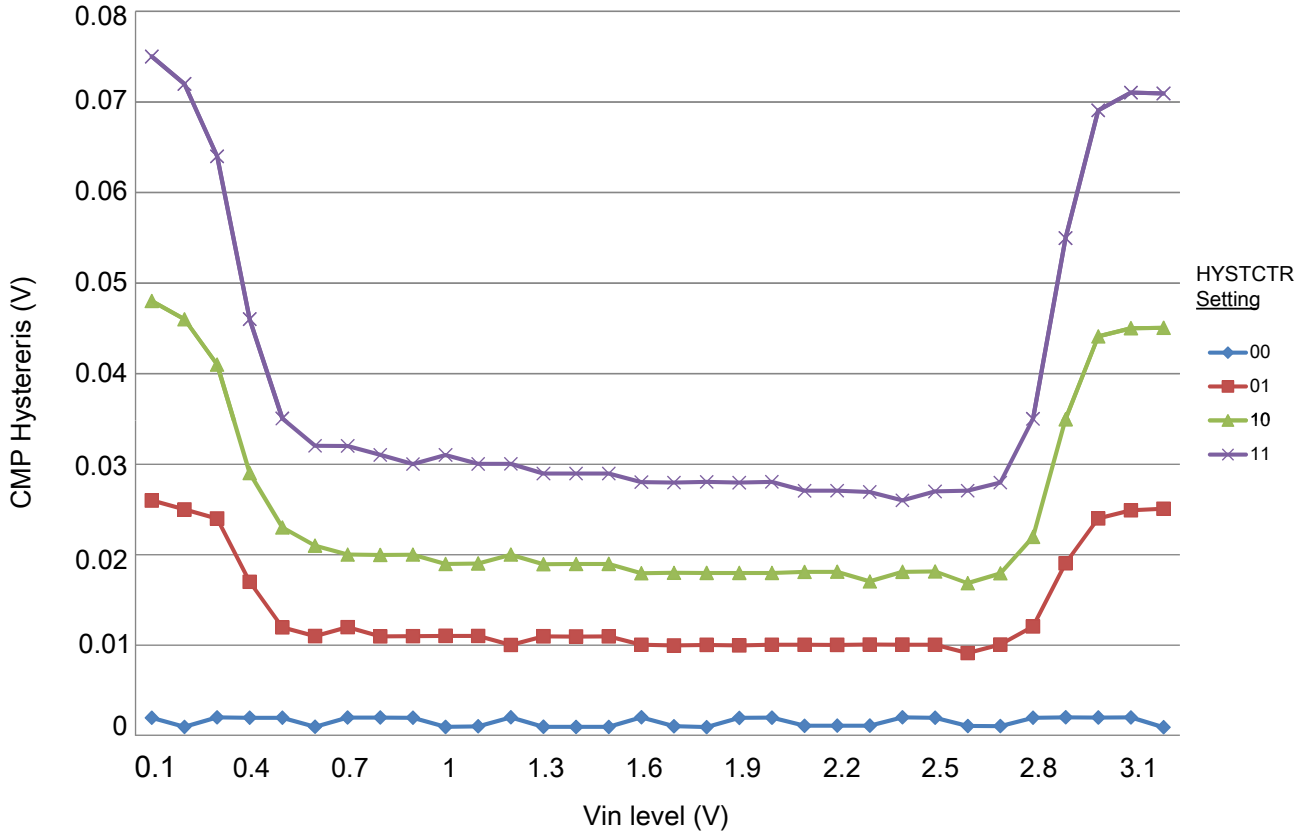

Figure 24. Typical hysteresis vs. Vin level (VDD = 3.3 V, PMODE = 0)

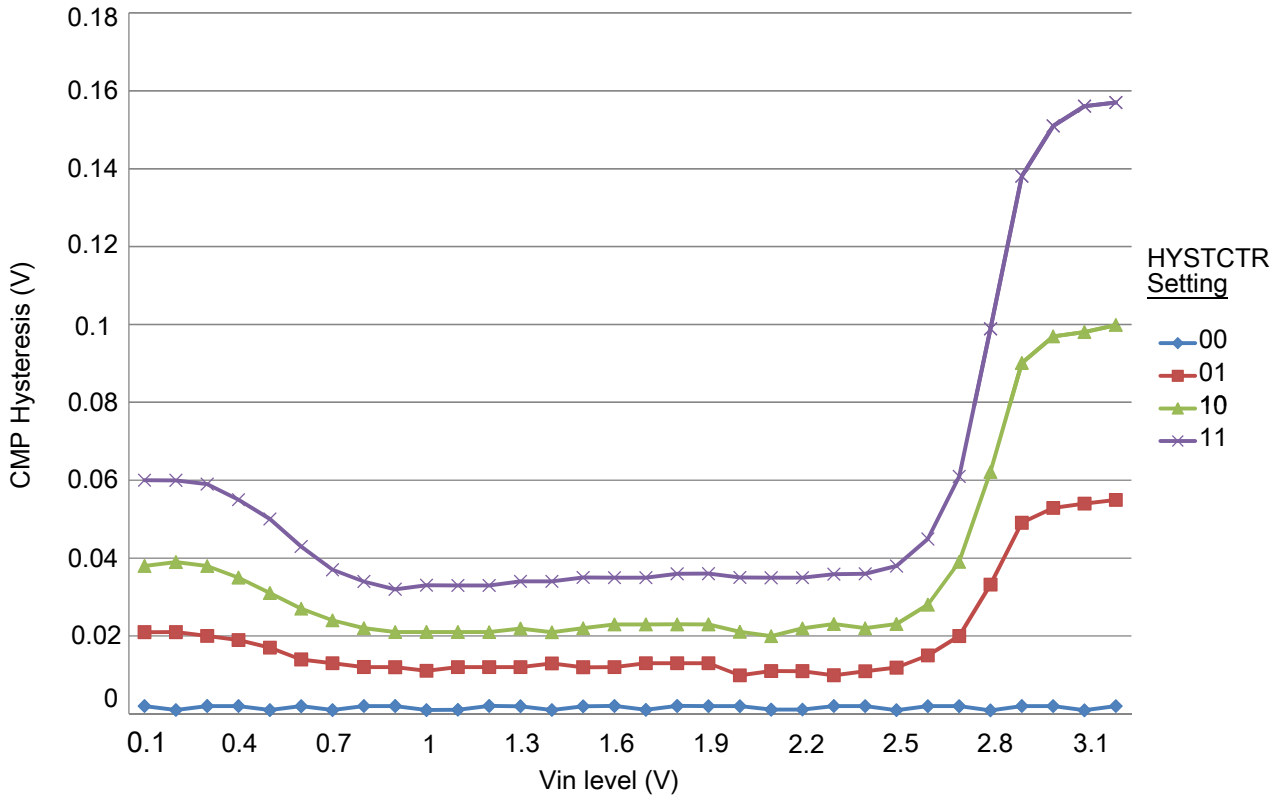

Figure 25. Typical hysteresis vs. Vin level (VDD = 3.3 V, PMODE = 1)

### 3.4.3 12-bit DAC electrical characteristics

#### 3.4.3.1 12-bit DAC operating requirements

Table 43. 12-bit DAC operating requirements

Symbol	Description	Min.	Max.	Unit	Notes
$V_{DDA}$	Supply voltage		3.6	V	
$V_{DACR}$	Reference voltage	1.13	3.6	V	1
$C_L$	Output load capacitance	—	100	pF	2
$I_L$	Output load current	—	1	mA	

1. The DAC reference can be selected to be  $V_{DDA}$  or  $V_{REFH}$ .
2. A small load capacitance (47 pF) can improve the bandwidth performance of the DAC.

## 3.4.3.2 12-bit DAC operating behaviors

Table 44. 12-bit DAC operating behaviors

Symbol	Description	Min.	Typ.	Max.	Unit	Notes
$I_{DDA\_DACLP}$	Supply current — low-power mode	—	—	150	$\mu\text{A}$	
$I_{DDA\_DACHP}$	Supply current — high-speed mode	—	—	700	$\mu\text{A}$	
$t_{DACLP}$	Full-scale settling time (0x080 to 0xF7F) — low-power mode	—	100	200	$\mu\text{s}$	1
$t_{DACHP}$	Full-scale settling time (0x080 to 0xF7F) — high-power mode	—	15	30	$\mu\text{s}$	1
$t_{CCDACLP}$	Code-to-code settling time (0xBF8 to 0xC08) — low-power mode and high-speed mode	—	0.7	1	$\mu\text{s}$	1
$V_{dacoutl}$	DAC output voltage range low — high-speed mode, no load, DAC set to 0x000	—	—	100	mV	
$V_{dacouth}$	DAC output voltage range high — high-speed mode, no load, DAC set to 0xFFF	$V_{DACR} - 100$	—	$V_{DACR}$	mV	
INL	Integral non-linearity error — high speed mode	—	—	$\pm 8$	LSB	2
DNL	Differential non-linearity error — $V_{DACR} > 2\text{ V}$	—	—	$\pm 1$	LSB	3
DNL	Differential non-linearity error — $V_{DACR} = V_{REF\_OUT}$	—	—	$\pm 1$	LSB	4
$V_{OFFSET}$	Offset error	—	$\pm 0.4$	$\pm 0.8$	%FSR	5
$E_G$	Gain error	—	$\pm 0.1$	$\pm 0.6$	%FSR	5
PSRR	Power supply rejection ratio, $V_{DDA} \geq 2.4\text{ V}$	60	—	90	dB	
$T_{CO}$	Temperature coefficient offset voltage	—	3.7	—	$\mu\text{V}/\text{C}$	6
$T_{GE}$	Temperature coefficient gain error	—	0.000421	—	%FSR/C	
$A_C$	Offset aging coefficient	—	—	100	$\mu\text{V}/\text{yr}$	
$R_{op}$	Output resistance (load = 3 k $\Omega$ )	—	—	250	$\Omega$	
SR	Slew rate -80h → F7Fh → 80h <ul style="list-style-type: none"> <li>High power (<math>SP_{HP}</math>)</li> <li>Low power (<math>SP_{LP}</math>)</li> </ul>	1.2 0.05	1.7 0.12	— —	$\text{V}/\mu\text{s}$	
CT	Channel to channel cross talk	—	—	-80	dB	
BW	3dB bandwidth <ul style="list-style-type: none"> <li>High power (<math>SP_{HP}</math>)</li> <li>Low power (<math>SP_{LP}</math>)</li> </ul>	550 40	— —	— —	kHz	

- Settling within  $\pm 1$  LSB
- The INL is measured for 0 + 100 mV to  $V_{DACR} - 100$  mV
- The DNL is measured for 0 + 100 mV to  $V_{DACR} - 100$  mV
- The DNL is measured for 0 + 100 mV to  $V_{DACR} - 100$  mV with  $V_{DDA} > 2.4\text{ V}$
- Calculated by a best fit curve from  $V_{SS} + 100$  mV to  $V_{DACR} - 100$  mV

6.  $V_{DDA} = 3.0\text{ V}$ , reference select set for  $V_{DDA}$  (DACx\_CO:DACRFS = 1), high power mode (DACx\_C0:LPEN = 0), DAC set to 0x800, temperature range is across the full range of the device

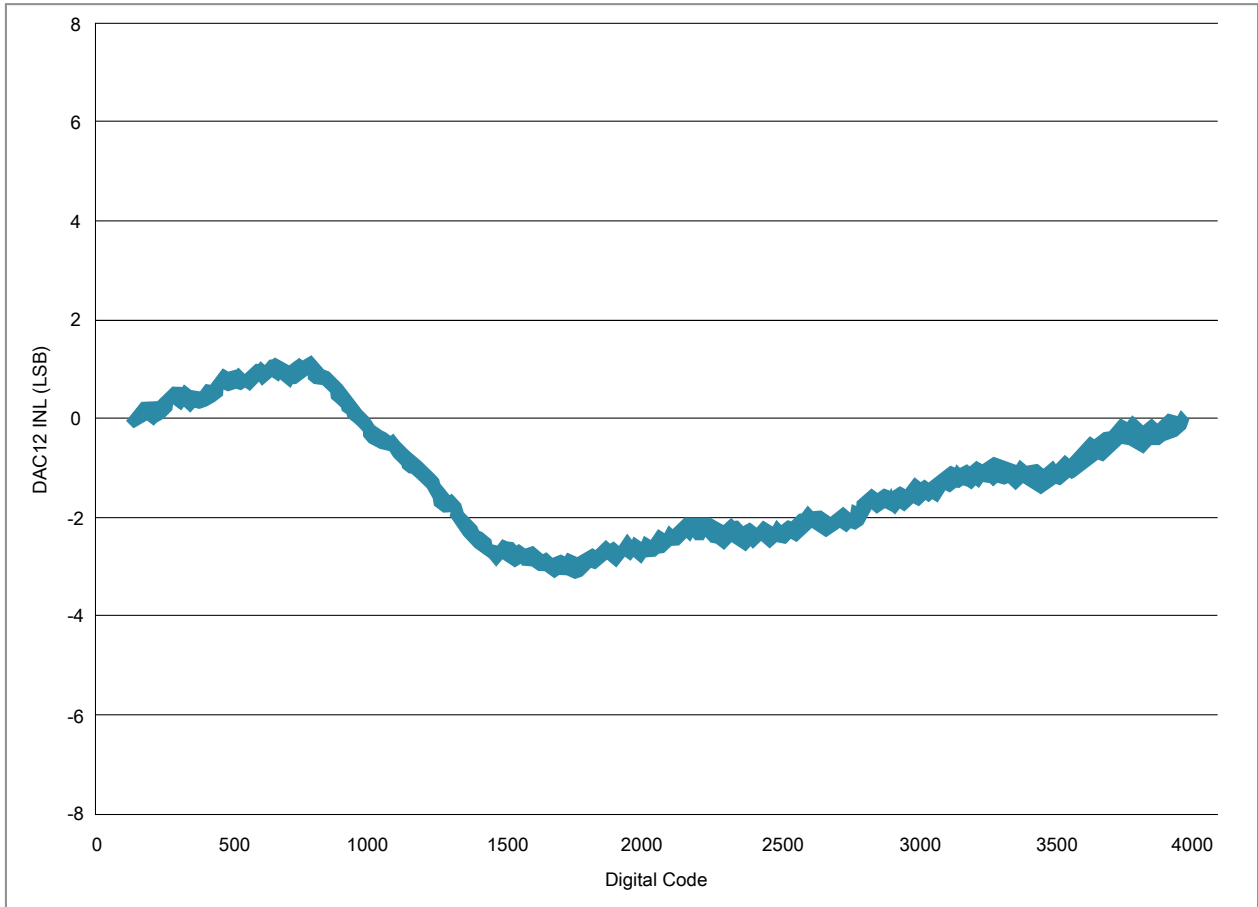

**Figure 26. Typical INL error vs. digital code**

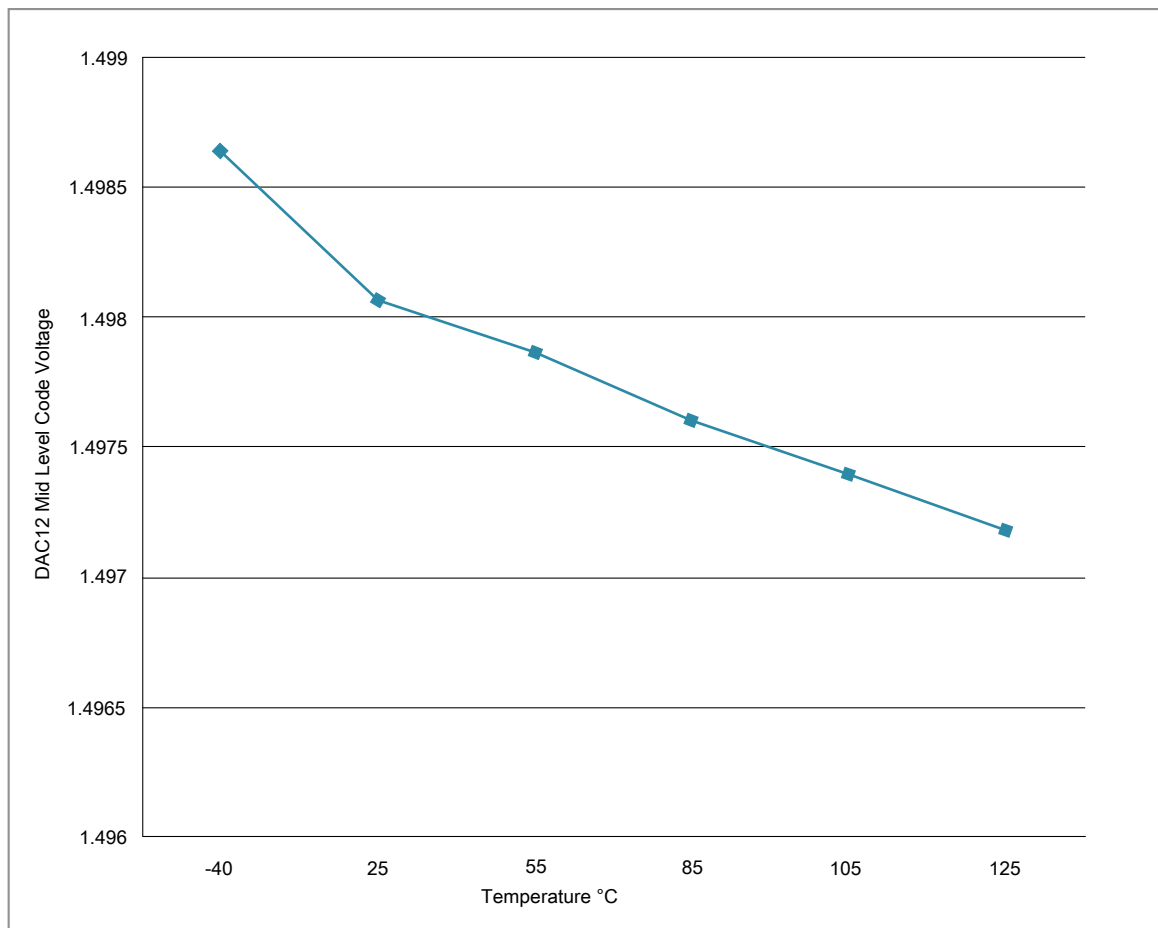

Figure 27. Offset at half scale vs. temperature

### 3.4.4 Voltage reference electrical specifications

Table 45. VREF full-range operating requirements

Symbol	Description	Min.	Max.	Unit	Notes
V <sub>DDA</sub>	Supply voltage		3.6	V	
T <sub>A</sub>	Temperature	Operating temperature range of the device		°C	
C <sub>L</sub>	Output load capacitance	100		nF	1, 2

1. C<sub>L</sub> must be connected to VREF\_OUT if the VREF\_OUT functionality is being used for either an internal or external reference.
2. The load capacitance should not exceed +/-25% of the nominal specified C<sub>L</sub> value over the operating temperature range of the device.

**Table 46. VREF full-range operating behaviors**

Symbol	Description	Min.	Typ.	Max.	Unit	Notes
V <sub>out</sub>	Voltage reference output with factory trim at nominal V <sub>DDA</sub> and temperature=25C	1.190	1.195	1.200	V	1
V <sub>out</sub>	Voltage reference output — user trim	1.1945	1.195	1.1955	V	1
V <sub>step</sub>	Voltage reference trim step	—	0.5	—	mV	1
V <sub>tdrift</sub>	Voltage reference voltage drift (V <sub>max</sub> -V <sub>min</sub> ) due to variation of temperature across the full temperature range	—	2	15	mV	1
I <sub>bg</sub>	Bandgap only current	—	60	80	μA	1
I <sub>lp</sub>	Low-power buffer current	—	180	360	uA	1
I <sub>hp</sub>	High-power buffer current	—	480	960	mA	1
ΔV <sub>LOAD</sub>	Load regulation • current = ± 1.0 mA	—	200	—	μV	1, 2
T <sub>stup</sub>	Buffer startup time	—	—	100	μs	
T <sub>chop_osc_st up</sub>	Internal bandgap start-up delay with chop oscillator enabled	—	—	35	ms	—
V <sub>vdrift</sub>	Voltage reference voltage drift (V <sub>max</sub> -V <sub>min</sub> ) due to variation of VDDA between 1.9V-1.71V	—	0.5	2	mV	1

1. See the chip's Reference Manual for the appropriate settings of the VREF Status and Control register.
2. Load regulation voltage is the difference between the VREF\_OUT voltage with no load vs. voltage with defined load.

## 3.5 Timers

See [General switching specifications](#).

## 3.6 Communication interfaces

### 3.6.1 USB Voltage Regulator electrical specifications

**Table 47. USB VREG electrical specifications**

Symbol	Description	Min.	Typ. <sup>1</sup>	Max.	Unit	Notes
VREG_IN0 VREG_IN1	Regulator selectable input supply voltages	2.7	—	5.5	V	2
I <sub>DDon</sub> VREG_IN0	Quiescent current — Run mode, load current equal zero, input supply (VREG_IN*) > 3.6 V	—	157	—	μA	

*Table continues on the next page...*

**Table 47. USB VREG electrical specifications  
(continued)**

Symbol	Description	Min.	Typ. <sup>1</sup>	Max.	Unit	Notes
VREG_IN1		—	157	—		
I <sub>DDstby</sub> VREG_IN0 VREG_IN1	Quiescent current — Standby mode, load current equal zero	— —	2 2	— —	μA	
I <sub>DDoff</sub> VREG_IN0 VREG_IN1	Quiescent current — Shutdown mode • VREG_IN*= 5.0 V and temperature=25 °C	— —	680 920	— —	nA	
I <sub>LOADrun</sub>	Maximum load current — Run mode	—	—	150	mA	3
I <sub>LOADstby</sub>	Maximum load current — Standby mode	—	—	1	mA	
V <sub>DROPOUT</sub>	Regulator drop-out voltage — Run mode at maximum load current with inrush current limit disabled	300	—	—	mV	
VREG_OUT	Regulator programmable output target voltage — Selected input supply > programmed output target voltage + V <sub>DROPOUT</sub> • Run mode • Standby mode	3 2.1	3.3 2.8	3.6 3.6	V V	4
C <sub>OUT</sub>	External output capacitor	1.76	2.2	8.16	μF	
ESR	External output capacitor equivalent series resistance	1	—	100	mΩ	
I <sub>LIM</sub>	Short circuit current	—	350	—	mA	5
I <sub>INRUSH</sub>	Inrush current limit	40	—	100	mA	6, 7, 8, 9

1. Typical values assume the selected input supply is 5.0 V, Temp = 25 °C unless otherwise stated.
2. Operation range is 2.7 V to 5.5 V; tolerance voltage is up to 6 V.
3. 150mA is inclusive of the run mode current of the on-chip USB modules. Available load outside of the chip depends on USB operation and device power dissipation limits.
4. The target voltage for the regulator is programmable, accounting for the range of the max and min values.
5. Current limit disabled.
6. Current limit should be disabled after the powers have stabilized to allow full functionality of the regulator.
7. Limited Characterization
8. I<sub>INRUSH</sub> with VREGINx=4.0 V to 5.5 V
9. Total current load on startup should be less than I<sub>INRUSH</sub> min over full input voltage range of the regulator.

### 3.6.2 USB Full Speed Transceiver and High Speed PHY specifications

This section describes the USB0 port Full Speed/Low Speed transceiver and USB1 port USB-PHY High Speed Phy parameters. The high speed phy is capable of full and low speed as well.

The USB0 (FS/LS Transceiver) and USB1 ((USB HS/FS/LS) meet the electrical compliance requirements defined in the Universal Serial Bus Revision 2.0 Specification with the amendments below.

- USB ENGINEERING CHANGE NOTICE
  - Title: 5V Short Circuit Withstand Requirement Change
  - Applies to: Universal Serial Bus Specification, Revision 2.0
- Errata for USB Revision 2.0 April 27, 2000 as of 12/7/2000
- USB ENGINEERING CHANGE NOTICE
  - Title: Pull-up/Pull-down resistors
  - Applies to: Universal Serial Bus Specification, Revision 2.0
- USB ENGINEERING CHANGE NOTICE
  - Title: Suspend Current Limit Changes
  - Applies to: Universal Serial Bus Specification, Revision 2.0
- On-The-Go and Embedded Host Supplement to the USB Revision 2.0 Specification
  - Revision 2.0 version 1.1a July 27, 2012
- Battery Charging Specification (available from USB-IF)
  - Revision 1.2 (including errata and ECNs through March 15, 2012), March 15, 2012

USB1\_VBUS pin is a detector function which is 5v tolerant and complies with the above specifications without needing any external voltage division components.

### 3.6.3 USB DCD electrical specifications

**Table 48. USB DCD electrical specifications**

Symbol	Description	Min.	Typ.	Max.	Unit
V <sub>DP_SRC</sub> , V <sub>DM_SRC</sub>	USB_DP and USB_DM source voltages (up to 250 $\mu$ A)	0.5	—	0.7	V
V <sub>LGC</sub>	Threshold voltage for logic high	0.8	—	2.0	V
I <sub>DP_SRC</sub>	USB_DP source current	7	10	13	$\mu$ A
I <sub>DM_SINK</sub> , I <sub>DP_SINK</sub>	USB_DM and USB_DP sink currents	50	100	150	$\mu$ A

*Table continues on the next page...*

**Table 48. USB DCD electrical specifications  
(continued)**

Symbol	Description	Min.	Typ.	Max.	Unit
R <sub>DM_DWN</sub>	D- pulldown resistance for data pin contact detect	14.25	—	24.8	kΩ
V <sub>DAT_REF</sub>	Data detect voltage	0.25	0.33	0.4	V

### 3.6.4 DSPI switching specifications (limited voltage range)

The DMA Serial Peripheral Interface (DSPI) provides a synchronous serial bus with master and slave operations. Many of the transfer attributes are programmable. The tables below provide DSPI timing characteristics for classic SPI timing modes. Refer to the DSPI chapter of the Reference Manual for information on the modified transfer formats used for communicating with slower peripheral devices.

**Table 49. Master mode DSPI timing (limited voltage range)**

Num	Description	Min.	Max.	Unit	Notes
	Operating voltage	2.7	3.6	V	
	Frequency of operation	—	30	MHz	
DS1	DSPI_SCK output cycle time	2 × t <sub>BUS</sub>	—	ns	
DS2	DSPI_SCK output high/low time	(t <sub>SCK</sub> /2) – 2	(t <sub>SCK</sub> /2) + 2	ns	
DS3	DSPI_PCS <sub>n</sub> valid to DSPI_SCK delay	(t <sub>BUS</sub> × 2) – 2	—	ns	1
DS4	DSPI_SCK to DSPI_PCS <sub>n</sub> invalid delay	(t <sub>BUS</sub> × 2) – 2	—	ns	2
DS5	DSPI_SCK to DSPI_SOUT valid	—	15.0	ns	
DS6	DSPI_SCK to DSPI_SOUT invalid	1.0	—	ns	
DS7	DSPI_SIN to DSPI_SCK input setup	15.8	—	ns	
DS8	DSPI_SCK to DSPI_SIN input hold	0	—	ns	

1. The delay is programmable in SPIx\_CTARn[PSSCK] and SPIx\_CTARn[CSSCK].
2. The delay is programmable in SPIx\_CTARn[PASC] and SPIx\_CTARn[ASC].

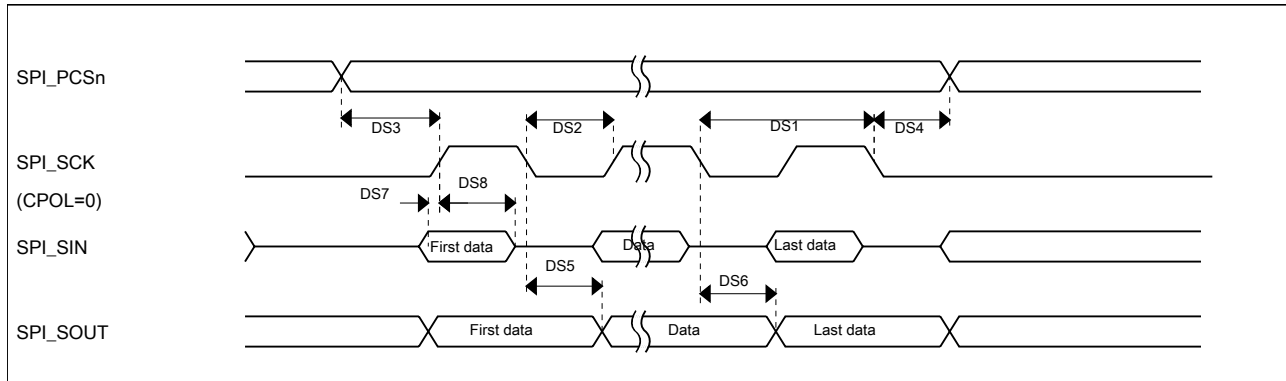

Figure 28. DSPI classic SPI timing — master mode

Table 50. Slave mode DSPI timing (limited voltage range)

Num	Description	Min.	Max.	Unit
	Operating voltage	2.7	3.6	V
	Frequency of operation	—	15 <sup>1</sup>	MHz
DS9	DSPI_SCK input cycle time	4 x t <sub>BUS</sub>	—	ns
DS10	DSPI_SCK input high/low time	(t <sub>SCK</sub> /2) - 2	(t <sub>SCK</sub> /2) + 2	ns
DS11	DSPI_SCK to DSPI_SOUT valid	—	23.0	ns
DS12	DSPI_SCK to DSPI_SOUT invalid	0	—	ns
DS13	DSPI_SIN to DSPI_SCK input setup	2.7	—	ns
DS14	DSPI_SCK to DSPI_SIN input hold	7.0	—	ns
DS15	$\overline{\text{DSPI\_SS}}$ active to DSPI_SOUT driven	—	13	ns
DS16	$\overline{\text{DSPI\_SS}}$ inactive to DSPI_SOUT not driven	—	13	ns

1. The maximum operating frequency is measured with non-continuous CS and SCK. When DSPI is configured with continuous CS and SCK, there is a constraint that SPI clock should not be greater than 1/6 of bus clock, for example, when bus clock is 60MHz, SPI clock should not be greater than 10MHz.

Peripheral operating requirements and behaviors

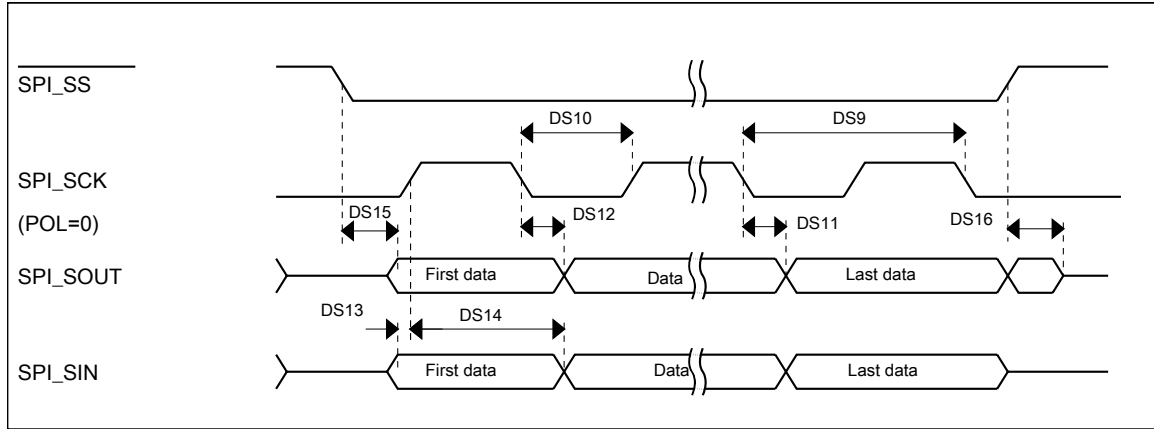

Figure 29. DSPI classic SPI timing — slave mode

Table 51. Master mode DSPI3 timing (limited voltage range)

Num	Description	Min.	Max.	Unit	Notes
	Operating voltage	2.7	3.6	V	
	Frequency of operation	—	60	MHz	
DS1	DSPI_SCK output cycle time	$2 \times t_{BUS}$	—	ns	
DS2	DSPI_SCK output high/low time	$(t_{SCK}/2) - 2$	$(t_{SCK}/2) + 2$	ns	
DS3	DSPI_PCSn valid to DSPI_SCK delay	$(t_{BUS} \times 2) - 2$	—	ns	1
DS4	DSPI_SCK to DSPI_PCSn invalid delay	$(t_{BUS} \times 2) - 2$	—	ns	2
DS5	DSPI_SCK to DSPI_SOUT valid	—	9.1	ns	
DS6	DSPI_SCK to DSPI_SOUT invalid	1.0	—	ns	
DS7	DSPI_SIN to DSPI_SCK input setup	7.8	—	ns	
DS8	DSPI_SCK to DSPI_SIN input hold	0	—	ns	

1. The delay is programmable in SPIx\_CTARn[PSSCK] and SPIx\_CTARn[CSSCK].
2. The delay is programmable in SPIx\_CTARn[PASC] and SPIx\_CTARn[ASC].

Table 52. Slave mode DSPI3 timing (limited voltage range)

Num	Description	Min.	Max.	Unit
	Operating voltage	2.7	3.6	V
	Frequency of operation	—	30 <sup>1</sup>	MHz
DS9	DSPI_SCK input cycle time	$4 \times t_{BUS}$	—	ns
DS10	DSPI_SCK input high/low time	$(t_{SCK}/2) - 2$	$(t_{SCK}/2) + 2$	ns
DS11	DSPI_SCK to DSPI_SOUT valid	—	16.0	ns
DS12	DSPI_SCK to DSPI_SOUT invalid	0	—	ns
DS13	DSPI_SIN to DSPI_SCK input setup	2.7	—	ns
DS14	DSPI_SCK to DSPI_SIN input hold	7.0	—	ns

Table continues on the next page...

**Table 52. Slave mode DSPI3 timing (limited voltage range) (continued)**

Num	Description	Min.	Max.	Unit
DS15	DSPI_SS active to DSPI_SOUT driven	—	13	ns
DS16	DSPI_SS inactive to DSPI_SOUT not driven	—	13	ns

1. The maximum operating frequency is measured with non-continuous CS and SCK. When DSPI is configured with continuous CS and SCK, there is a constraint that SPI clock should not be greater than 1/6 of bus clock, for example, when bus clock is 60MHz, SPI clock should not be greater than 10MHz.

### 3.6.5 DSPI switching specifications (full voltage range)

The DMA Serial Peripheral Interface (DSPI) provides a synchronous serial bus with master and slave operations. Many of the transfer attributes are programmable. The tables below provides DSPI timing characteristics for classic SPI timing modes. Refer to the DSPI chapter of the Reference Manual for information on the modified transfer formats used for communicating with slower peripheral devices.

**Table 53. Master mode DSPI timing (full voltage range)**

Num	Description	Min.	Max.	Unit	Notes
	Operating voltage	1.71	3.6	V	1
	Frequency of operation	—	15	MHz	
DS1	DSPI_SCK output cycle time	$4 \times t_{BUS}$	—	ns	
DS2	DSPI_SCK output high/low time	$(t_{SCK/2}) - 4$	$(t_{SCK/2}) + 4$	ns	
DS3	DSPI_PCS <sub>n</sub> valid to DSPI_SCK delay	$(t_{BUS} \times 2) - 4$	—	ns	2
DS4	DSPI_SCK to DSPI_PCS <sub>n</sub> invalid delay	$(t_{BUS} \times 2) - 4$	—	ns	3
DS5	DSPI_SCK to DSPI_SOUT valid	—	16	ns	
DS6	DSPI_SCK to DSPI_SOUT invalid	1.0	—	ns	
DS7	DSPI_SIN to DSPI_SCK input setup	19.1	—	ns	
DS8	DSPI_SCK to DSPI_SIN input hold	0	—	ns	

1. The DSPI module can operate across the entire operating voltage for the processor, but to run across the full voltage range the maximum frequency of operation is reduced.
2. The delay is programmable in SPIx\_CTARn[PSSCK] and SPIx\_CTARn[CSSCK].
3. The delay is programmable in SPIx\_CTARn[PASC] and SPIx\_CTARn[ASC].

Peripheral operating requirements and behaviors

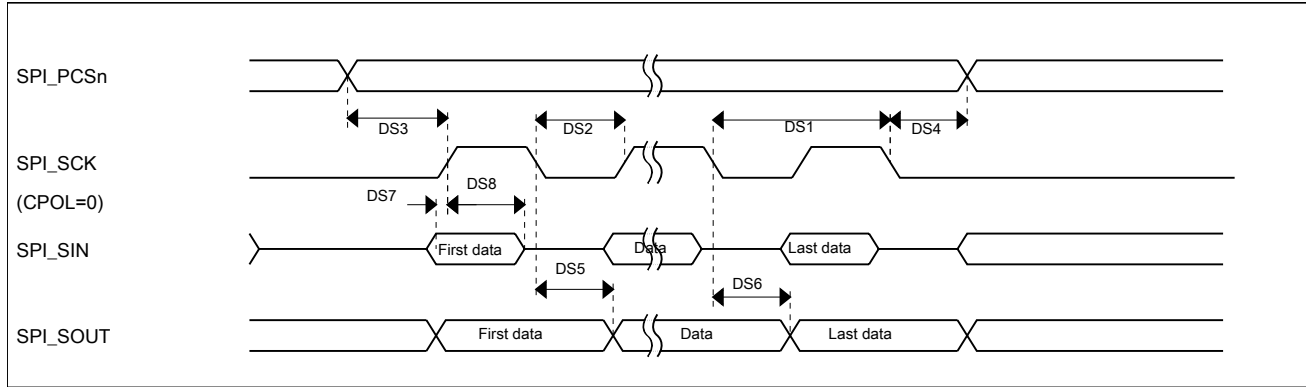

Figure 30. DSPI classic SPI timing — master mode

Table 54. Slave mode DSPI timing (full voltage range)

Num	Description	Min.	Max.	Unit
	Operating voltage	1.71	3.6	V
	Frequency of operation	—	7.5	MHz
DS9	DSPI_SCK input cycle time	$8 \times t_{BUS}$	—	ns
DS10	DSPI_SCK input high/low time	$(t_{SCK}/2) - 4$	$(t_{SCK}/2) + 4$	ns
DS11	DSPI_SCK to DSPI_SOUT valid	—	23.1	ns
DS12	DSPI_SCK to DSPI_SOUT invalid	0	—	ns
DS13	DSPI_SIN to DSPI_SCK input setup	2.6	—	ns
DS14	DSPI_SCK to DSPI_SIN input hold	7.0	—	ns
DS15	DSPI_SS active to DSPI_SOUT driven	—	13.0	ns
DS16	DSPI_SS inactive to DSPI_SOUT not driven	—	13.0	ns

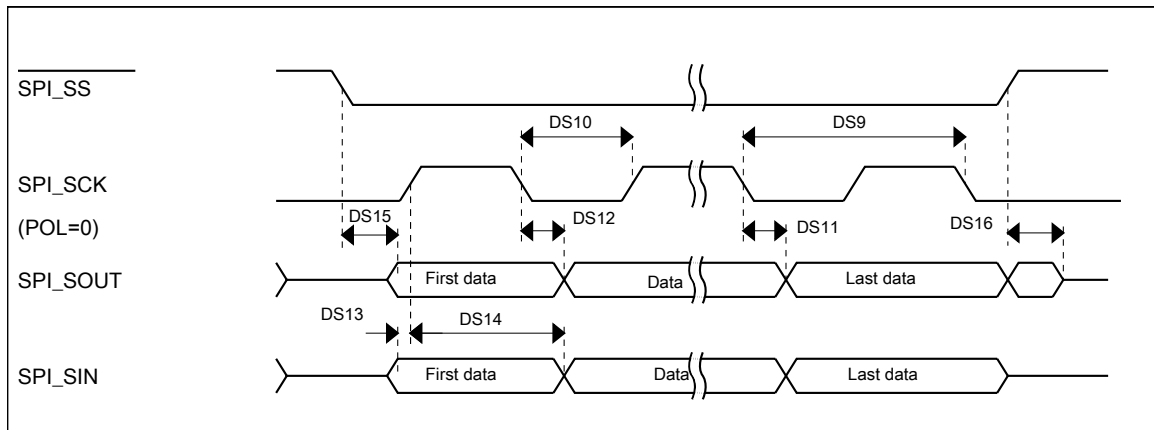

Figure 31. DSPI classic SPI timing — slave mode

**Table 55. Master mode DSPI3 timing (full voltage range)**

Num	Description	Min.	Max.	Unit	Notes
	Operating voltage	1.71	3.6	V	
	Frequency of operation	—	40	MHz	
DS1	DSPI_SCK output cycle time	$2 \times t_{BUS}$	—	ns	
DS2	DSPI_SCK output high/low time	$(t_{SCK/2}) - 2$	$(t_{SCK/2}) + 2$	ns	
DS3	DSPI_PCS <sub>n</sub> valid to DSPI_SCK delay	$(t_{BUS} \times 2) - 2$	—	ns	1
DS4	DSPI_SCK to DSPI_PCS <sub>n</sub> invalid delay	$(t_{BUS} \times 2) - 2$	—	ns	2
DS5	DSPI_SCK to DSPI_SOUT valid	—	9.5	ns	
DS6	DSPI_SCK to DSPI_SOUT invalid	1.0	—	ns	
DS7	DSPI_SIN to DSPI_SCK input setup	10.5	—	ns	
DS8	DSPI_SCK to DSPI_SIN input hold	0.0	—	ns	

1. The delay is programmable in SPIx\_CTARn[PSSCK] and SPIx\_CTARn[CSSCK].
2. The delay is programmable in SPIx\_CTARn[PASC] and SPIx\_CTARn[ASC].

**Table 56. Slave mode DSPI3 timing (full voltage range)**

Num	Description	Min.	Max.	Unit	Notes>
	Operating voltage	1.71	3.6	V	
	Frequency of operation	—	20	MHz	1
DS9	DSPI_SCK input cycle time	$4 \times t_{BUS}$	—	ns	
DS10	DSPI_SCK input high/low time	$(t_{SCK/2}) - 2$	$(t_{SCK/2}) + 2$	ns	
DS11	DSPI_SCK to DSPI_SOUT valid	—	18.2	ns	
DS12	DSPI_SCK to DSPI_SOUT invalid	0.0	—	ns	
DS13	DSPI_SIN to DSPI_SCK input setup	2.7	—	ns	
DS14	DSPI_SCK to DSPI_SIN input hold	7.0	—	ns	
DS15	DSPI_SS active to DSPI_SOUT driven	—	13.0	ns	
DS16	DSPI_SS inactive to DSPI_SOUT not driven	—	13.0	ns	

1. The maximum operating frequency is measured with non-continuous CS and SCK. When DSPI is configured with continuous CS and SCK, there is a constraint that SPI clock should not be greater than 1/6 of bus clock, for example, when bus clock is 60MHz, SPI clock should not be greater than 10MHz.

### 3.6.6 Inter-Integrated Circuit Interface (I<sup>2</sup>C) timing

**Table 57. I<sup>2</sup>C timing**

Characteristic	Symbol	Standard Mode		Fast Mode		Unit
		Minimum	Maximum	Minimum	Maximum	
SCL Clock Frequency	f <sub>SCL</sub>	0	100	0	400	kHz

Table continues on the next page...

**Table 57. I<sup>2</sup>C timing (continued)**

Characteristic	Symbol	Standard Mode		Fast Mode		Unit
		Minimum	Maximum	Minimum	Maximum	
Hold time (repeated) START condition. After this period, the first clock pulse is generated.	t <sub>HD</sub> ; STA	4	—	0.6	—	μs
LOW period of the SCL clock	t <sub>LOW</sub>	4.7	—	1.25	—	μs
HIGH period of the SCL clock	t <sub>HIGH</sub>	4	—	0.6	—	μs
Set-up time for a repeated START condition	t <sub>SU</sub> ; STA	4.7	—	0.6	—	μs
Data hold time for I <sup>2</sup> C bus devices	t <sub>HD</sub> ; DAT	0 <sup>1</sup>	3.45 <sup>2</sup>	0 <sup>3</sup>	0.9 <sup>1</sup>	μs
Data set-up time	t <sub>SU</sub> ; DAT	250 <sup>4</sup>	—	100 <sup>2, 5</sup>	—	ns
Rise time of SDA and SCL signals	t <sub>r</sub>	—	1000	20 + 0.1C <sub>b</sub> <sup>6</sup>	300	ns
Fall time of SDA and SCL signals	t <sub>f</sub>	—	300	20 + 0.1C <sub>b</sub> <sup>5</sup>	300	ns
Set-up time for STOP condition	t <sub>SU</sub> ; STO	4	—	0.6	—	μs
Bus free time between STOP and START condition	t <sub>BUF</sub>	4.7	—	1.3	—	μs
Pulse width of spikes that must be suppressed by the input filter	t <sub>SP</sub>	N/A	N/A	0	50	ns

1. The master mode I<sup>2</sup>C deasserts ACK of an address byte simultaneously with the falling edge of SCL. If no slaves acknowledge this address byte, then a negative hold time can result, depending on the edge rates of the SDA and SCL lines.
2. The maximum t<sub>HD</sub>; DAT must be met only if the device does not stretch the LOW period (t<sub>LOW</sub>) of the SCL signal.
3. Input signal Slew = 10 ns and Output Load = 50 pF
4. Set-up time in slave-transmitter mode is 1 IPBus clock period, if the TX FIFO is empty.
5. A Fast mode I<sup>2</sup>C bus device can be used in a Standard mode I<sup>2</sup>C bus system, but the requirement t<sub>SU</sub>; DAT ≥ 250 ns must then be met. This is automatically the case if the device does not stretch the LOW period of the SCL signal. If such a device does stretch the LOW period of the SCL signal, then it must output the next data bit to the SDA line t<sub>rmax</sub> + t<sub>SU</sub>; DAT = 1000 + 250 = 1250 ns (according to the Standard mode I<sup>2</sup>C bus specification) before the SCL line is released.
6. C<sub>b</sub> = total capacitance of the one bus line in pF.

**Table 58. I<sup>2</sup>C 1 Mbps timing**

Characteristic	Symbol	Minimum	Maximum	Unit
SCL Clock Frequency	f <sub>SCL</sub>	0	1 <sup>1</sup>	MHz
Hold time (repeated) START condition. After this period, the first clock pulse is generated.	t <sub>HD</sub> ; STA	0.26	—	μs
LOW period of the SCL clock	t <sub>LOW</sub>	0.5	—	μs
HIGH period of the SCL clock	t <sub>HIGH</sub>	0.26	—	μs
Set-up time for a repeated START condition	t <sub>SU</sub> ; STA	0.26	—	μs
Data hold time for I <sup>2</sup> C bus devices	t <sub>HD</sub> ; DAT	0	—	μs
Data set-up time	t <sub>SU</sub> ; DAT	50	—	ns
Rise time of SDA and SCL signals	t <sub>r</sub>	20 + 0.1C <sub>b</sub> <sup>2</sup>	120	ns
Fall time of SDA and SCL signals	t <sub>f</sub>	20 + 0.1C <sub>b</sub> <sup>2</sup>	120	ns
Set-up time for STOP condition	t <sub>SU</sub> ; STO	0.26	—	μs

Table continues on the next page...

**Table 58. I<sup>2</sup>C 1 Mbps timing (continued)**

Characteristic	Symbol	Minimum	Maximum	Unit
Bus free time between STOP and START condition	$t_{BUF}$	0.5	—	$\mu$ s
Pulse width of spikes that must be suppressed by the input filter	$t_{SP}$	0	50	ns

1. The maximum SCL clock frequency of 1 Mbps can support maximum bus loading when using the High drive pins across the full voltage range.
2.  $C_b$  = total capacitance of the one bus line in pF.

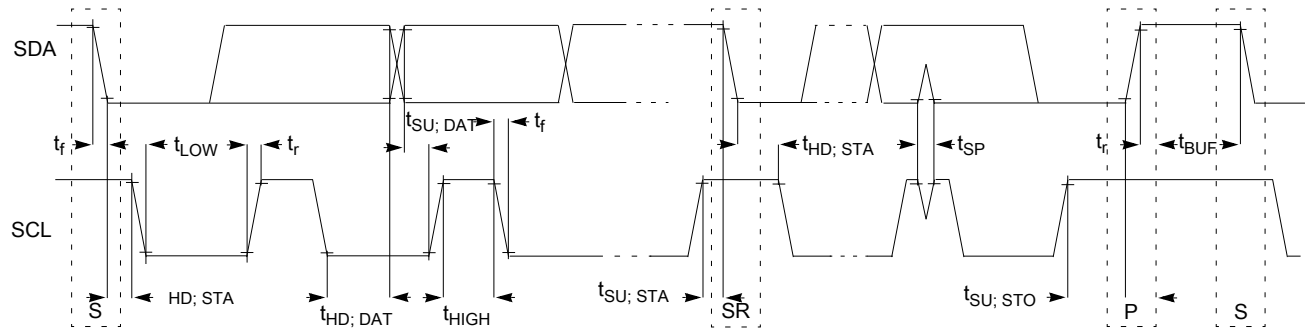
**Figure 32. Timing definition for devices on the I<sup>2</sup>C bus**

### 3.6.7 LPUART switching specifications

See [General switching specifications](#).

### 3.6.8 SDHC specifications

The following timing specs are defined at the chip I/O pin and must be translated appropriately to arrive at timing specs/constraints for the physical interface.

**Table 59. SDHC full voltage range switching specifications**

Num	Symbol	Description	Min.	Max.	Unit
		Operating voltage	1.71	3.6	V
<b>Card input clock</b>					
SD1	f <sub>pp</sub>	Clock frequency (low speed)	0	400	kHz
	f <sub>pp</sub>	Clock frequency (SD\SDIO full speed\high speed)	0	25/45	MHz
	f <sub>pp</sub>	Clock frequency (MMC full speed\high speed)	0	25/45	MHz
	f <sub>OD</sub>	Clock frequency (identification mode)	0	400	kHz
SD2	t <sub>wL</sub>	Clock low time	7	—	ns
SD3	t <sub>wH</sub>	Clock high time	7	—	ns

Table continues on the next page...

**Table 59. SDHC full voltage range switching specifications (continued)**

Num	Symbol	Description	Min.	Max.	Unit
SD4	$t_{TLH}$	Clock rise time	—	3	ns
SD5	$t_{THL}$	Clock fall time	—	3	ns
<b>SDHC output / card inputs SDHC_CMD, SDHC_DAT (reference to SDHC_CLK)</b>					
SD6	$t_{OD}$	SDHC output delay (output valid)	0	8.1	ns
<b>SDHC input / card inputs SDHC_CMD, SDHC_DAT (reference to SDHC_CLK)</b>					
SD7	$t_{ISU}$	SDHC input setup time	5	—	ns
SD8	$t_{IH}$	SDHC input hold time	0	—	ns

**Table 60. SDHC limited voltage range switching specifications**

Num	Symbol	Description	Min.	Max.	Unit
		Operating voltage	2.7	3.6	V
<b>Card input clock</b>					
SD1	fpp	Clock frequency (low speed)	0	400	kHz
	fpp	Clock frequency (SD\SDIO full speed\high speed)	0	25\50	MHz
	fpp	Clock frequency (MMC full speed\high speed)	0	20\50	MHz
	$f_{OD}$	Clock frequency (identification mode)	0	400	kHz
SD2	$t_{WL}$	Clock low time	7	—	ns
SD3	$t_{WH}$	Clock high time	7	—	ns
SD4	$t_{TLH}$	Clock rise time	—	3	ns
SD5	$t_{THL}$	Clock fall time	—	3	ns
<b>SDHC output / card inputs SDHC_CMD, SDHC_DAT (reference to SDHC_CLK)</b>					
SD6	$t_{OD}$	SDHC output delay (output valid)	0	7	ns
<b>SDHC input / card inputs SDHC_CMD, SDHC_DAT (reference to SDHC_CLK)</b>					
SD7	$t_{ISU}$	SDHC input setup time	5	—	ns
SD8	$t_{IH}$	SDHC input hold time	0	—	ns

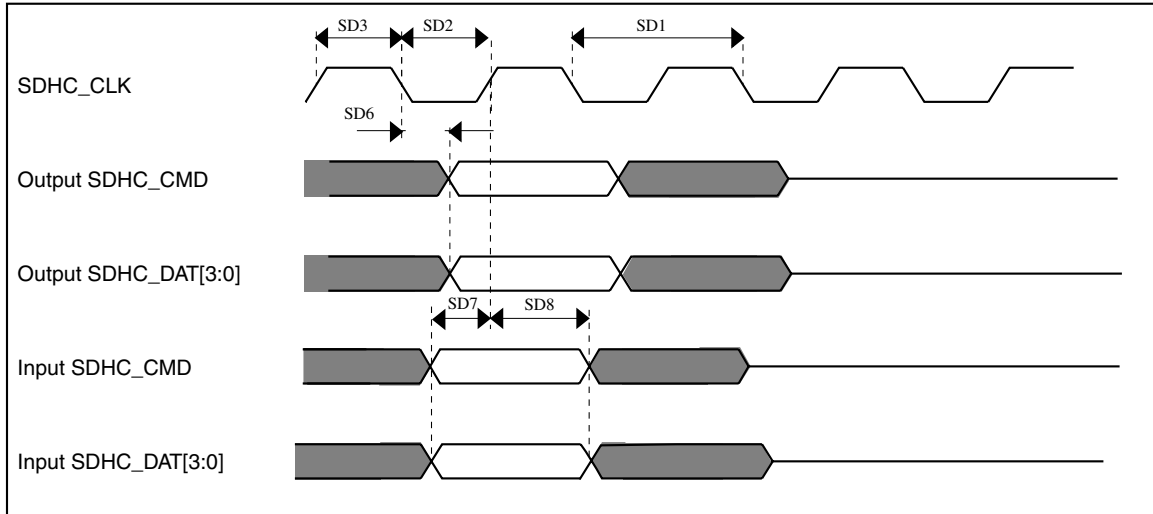

Figure 33. SDHC timing

### 3.6.9 I<sup>2</sup>S switching specifications

This section provides the AC timings for the I<sup>2</sup>S in master (clocks driven) and slave modes (clocks input). All timings are given for non-inverted serial clock polarity (TCR[TSCKP] = 0, RCR[RSCKP] = 0) and a non-inverted frame sync (TCR[TFSI] = 0, RCR[RFSI] = 0). If the polarity of the clock and/or the frame sync have been inverted, all the timings remain valid by inverting the clock signal (I2S\_BCLK) and/or the frame sync (I2S\_FS) shown in the figures below.

Table 61. I<sup>2</sup>S master mode timing (limited voltage range)

Num	Description	Min.	Max.	Unit
	Operating voltage	2.7	3.6	V
S1	I2S_MCLK cycle time	40	—	ns
S2	I2S_MCLK pulse width high/low	45%	55%	MCLK period
S3	I2S_BCLK cycle time	80	—	ns
S4	I2S_BCLK pulse width high/low	45%	55%	BCLK period
S5	I2S_BCLK to I2S_FS output valid	—	15	ns
S6	I2S_BCLK to I2S_FS output invalid	0	—	ns
S7	I2S_BCLK to I2S_TXD valid	—	15	ns
S8	I2S_BCLK to I2S_TXD invalid	0	—	ns
S9	I2S_RXD/I2S_FS input setup before I2S_BCLK	15	—	ns
S10	I2S_RXD/I2S_FS input hold after I2S_BCLK	0	—	ns

## Peripheral operating requirements and behaviors

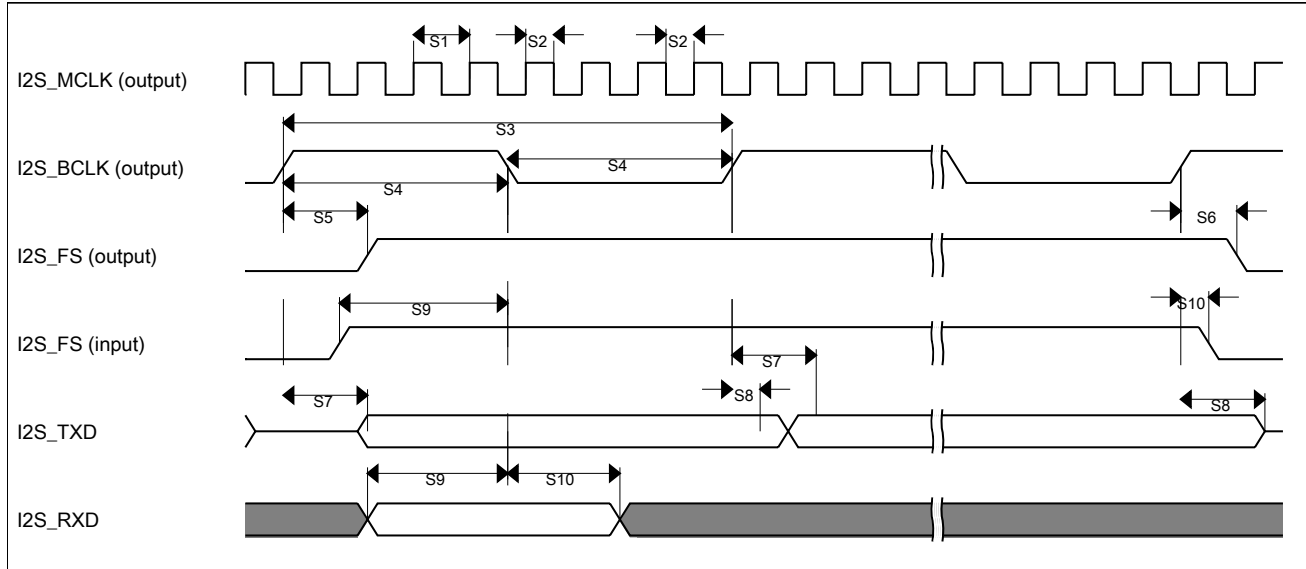
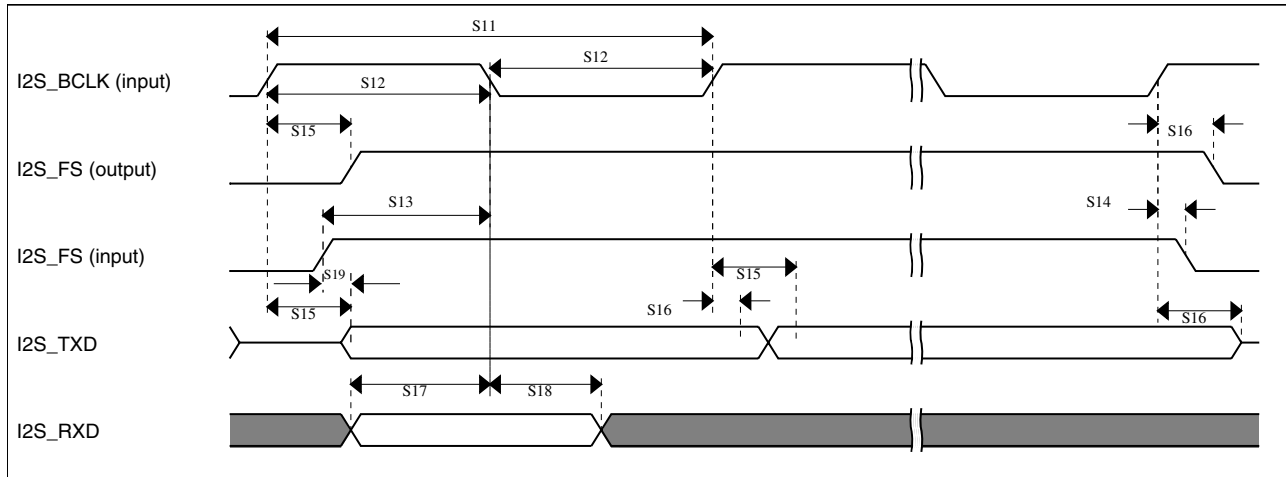

**Figure 34. I<sup>2</sup>S timing — master mode**

**Table 62. I<sup>2</sup>S slave mode timing (limited voltage range)**

Num	Description	Min.	Max.	Unit
	Operating voltage	2.7	3.6	V
S11	I2S_BCLK cycle time (input)	80	—	ns
S12	I2S_BCLK pulse width high/low (input)	45%	55%	MCLK period
S13	I2S_FS input setup before I2S_BCLK	4.5	—	ns
S14	I2S_FS input hold after I2S_BCLK	2	—	ns
S15	I2S_BCLK to I2S_TXD/I2S_FS output valid	—	20	ns
S16	I2S_BCLK to I2S_TXD/I2S_FS output invalid	0	—	ns
S17	I2S_RXD setup before I2S_BCLK	4.5	—	ns
S18	I2S_RXD hold after I2S_BCLK	2	—	ns
S19	I2S_TX_FS input assertion to I2S_TXD output valid <sup>1</sup>		25	ns

1. Applies to first bit in each frame and only if the TCR4[FSE] bit is clear

Figure 35. I<sup>2</sup>S timing — slave modes

### 3.6.9.1 Normal Run, Wait and Stop mode performance over the full operating voltage range

This section provides the operating performance over the full operating voltage for the device in Normal Run, Wait and Stop modes.

Table 63. I2S/SAI master mode timing

Num.	Characteristic	Min.	Max.	Unit
	Operating voltage	1.71	3.6	V
S1	I2S_MCLK cycle time	40	—	ns
S2	I2S_MCLK (as an input) pulse width high/low	45%	55%	MCLK period
S3	I2S_TX_BCLK/I2S_RX_BCLK cycle time (output)	80	—	ns
S4	I2S_TX_BCLK/I2S_RX_BCLK pulse width high/low	45%	55%	BCLK period
S5	I2S_TX_BCLK/I2S_RX_BCLK to I2S_TX_FS/ I2S_RX_FS output valid	—	15	ns
S6	I2S_TX_BCLK/I2S_RX_BCLK to I2S_TX_FS/ I2S_RX_FS output invalid	0	—	ns
S7	I2S_TX_BCLK to I2S_TXD valid	—	15	ns
S8	I2S_TX_BCLK to I2S_TXD invalid	0	—	ns
S9	I2S_RXD/I2S_RX_FS input setup before I2S_RX_BCLK	15	—	ns
S10	I2S_RXD/I2S_RX_FS input hold after I2S_RX_BCLK	0	—	ns

## Peripheral operating requirements and behaviors

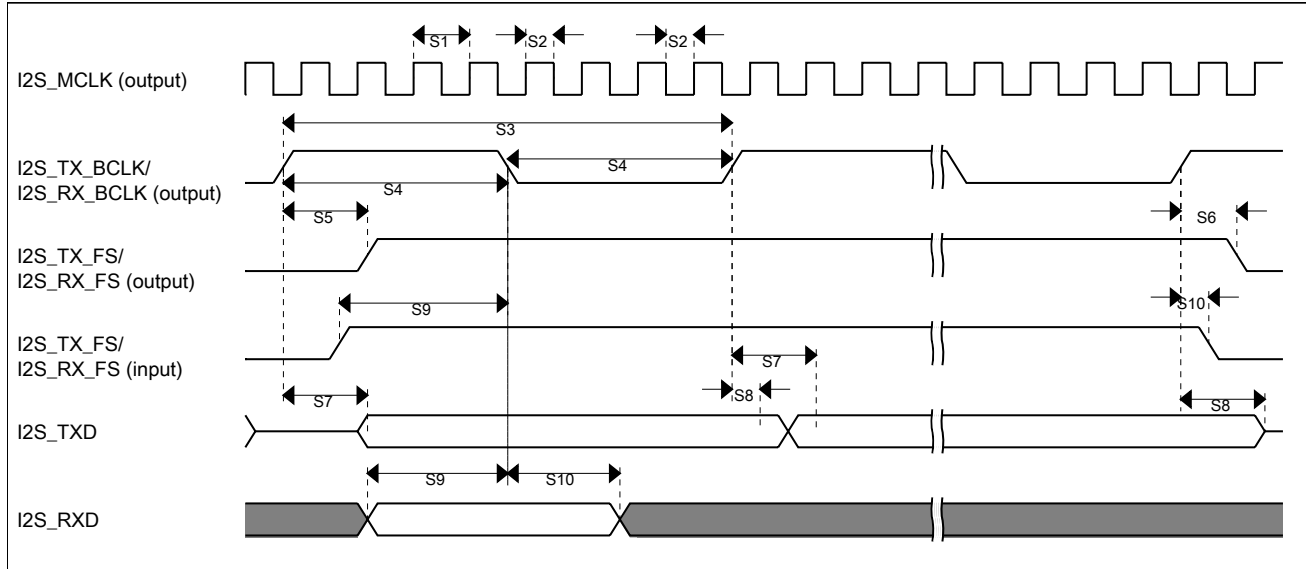

**Figure 36. I2S/SAI timing — master modes**

**Table 64. I2S/SAI slave mode timing**

Num.	Characteristic	Min.	Max.	Unit
	Operating voltage	1.71	3.6	V
S11	I2S_TX_BCLK/I2S_RX_BCLK cycle time (input)	80	—	ns
S12	I2S_TX_BCLK/I2S_RX_BCLK pulse width high/low (input)	45%	55%	MCLK period
S13	I2S_TX_FS/I2S_RX_FS input setup before I2S_TX_BCLK/I2S_RX_BCLK	4.5	—	ns
S14	I2S_TX_FS/I2S_RX_FS input hold after I2S_TX_BCLK/I2S_RX_BCLK	2	—	ns
S15	I2S_TX_BCLK to I2S_TXD/I2S_TX_FS output valid	—	23.1	ns
S16	I2S_TX_BCLK to I2S_TXD/I2S_TX_FS output invalid	0	—	ns
S17	I2S_RXD setup before I2S_RX_BCLK	4.5	—	ns
S18	I2S_RXD hold after I2S_RX_BCLK	2	—	ns
S19	I2S_TX_FS input assertion to I2S_TXD output valid <sup>1</sup>	—	25	ns

1. Applies to first bit in each frame and only if the TCR4[FSE] bit is clear

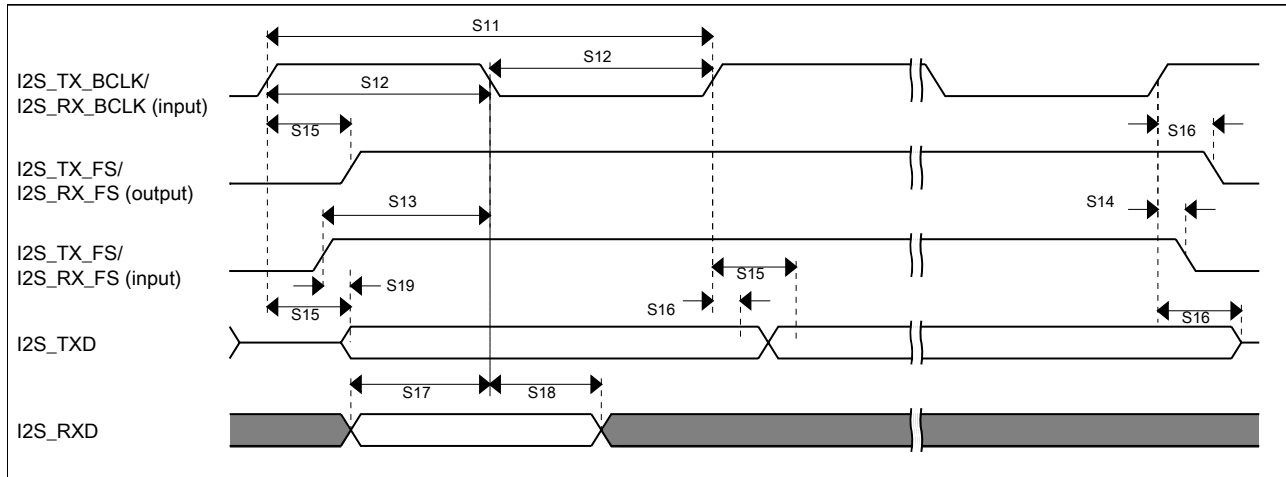

Figure 37. I2S/SAI timing — slave modes

### 3.6.9.2 VLPR, VLPW, and VLPS mode performance over the full operating voltage range

This section provides the operating performance over the full operating voltage for the device in VLPR, VLPW, and VLPS modes.

Table 65. I2S/SAI master mode timing in VLPR, VLPW, and VLPS modes (full voltage range)

Num.	Characteristic	Min.	Max.	Unit
	Operating voltage	1.71	3.6	V
S1	I2S_MCLK cycle time	62.5	—	ns
S2	I2S_MCLK pulse width high/low	45%	55%	MCLK period
S3	I2S_TX_BCLK/I2S_RX_BCLK cycle time (output)	250	—	ns
S4	I2S_TX_BCLK/I2S_RX_BCLK pulse width high/low	45%	55%	BCLK period
S5	I2S_TX_BCLK/I2S_RX_BCLK to I2S_TX_FS/ I2S_RX_FS output valid	—	45	ns
S6	I2S_TX_BCLK/I2S_RX_BCLK to I2S_TX_FS/ I2S_RX_FS output invalid	0	—	ns
S7	I2S_TX_BCLK to I2S_TXD valid	—	45	ns
S8	I2S_TX_BCLK to I2S_TXD invalid	0	—	ns
S9	I2S_RXD/I2S_RX_FS input setup before I2S_RX_BCLK	45	—	ns
S10	I2S_RXD/I2S_RX_FS input hold after I2S_RX_BCLK	0	—	ns

## Peripheral operating requirements and behaviors

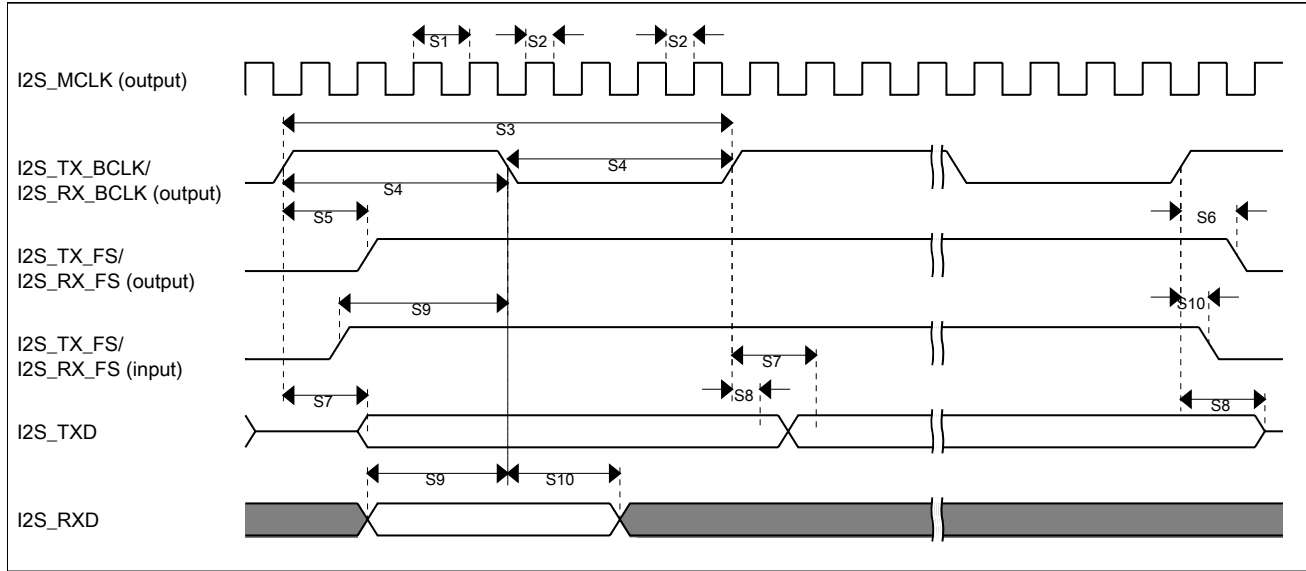

**Figure 38. I2S/SAI timing — master modes**

**Table 66. I2S/SAI slave mode timing in VLPR, VLPW, and VLPS modes (full voltage range)**

Num.	Characteristic	Min.	Max.	Unit
	Operating voltage	1.71	3.6	V
S11	I2S_TX_BCLK/I2S_RX_BCLK cycle time (input)	250	—	ns
S12	I2S_TX_BCLK/I2S_RX_BCLK pulse width high/low (input)	45%	55%	MCLK period
S13	I2S_TX_FS/I2S_RX_FS input setup before I2S_TX_BCLK/I2S_RX_BCLK	30	—	ns
S14	I2S_TX_FS/I2S_RX_FS input hold after I2S_TX_BCLK/I2S_RX_BCLK	5	—	ns
S15	I2S_TX_BCLK to I2S_TXD/I2S_TX_FS output valid	—	56.5	ns
S16	I2S_TX_BCLK to I2S_TXD/I2S_TX_FS output invalid	0	—	ns
S17	I2S_RXD setup before I2S_RX_BCLK	30	—	ns
S18	I2S_RXD hold after I2S_RX_BCLK	5	—	ns
S19	I2S_TX_FS input assertion to I2S_TXD output valid <sup>1</sup>	—	72	ns

1. Applies to first bit in each frame and only if the TCR4[FSE] bit is clear

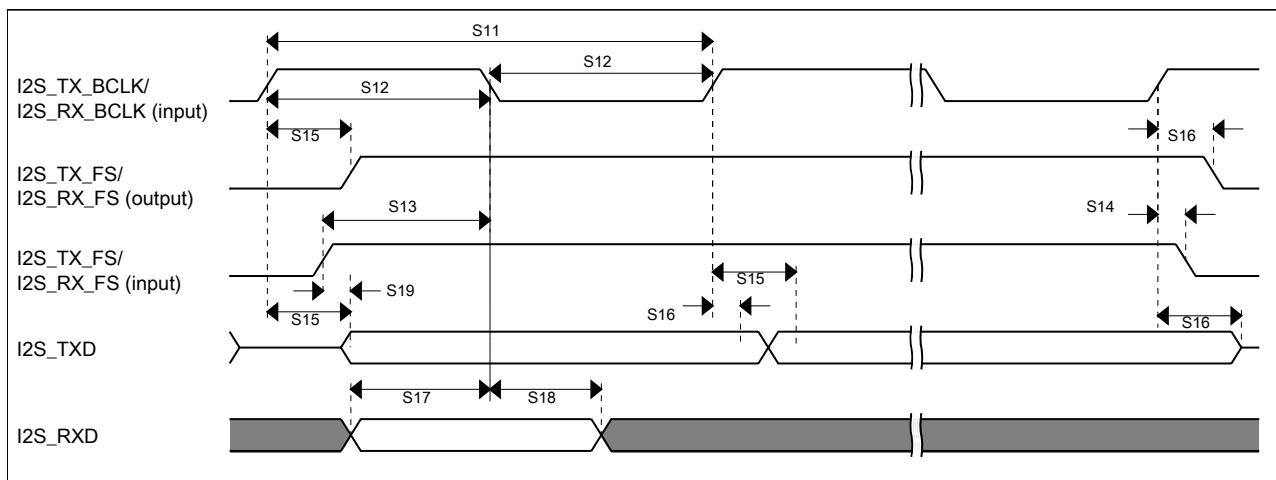

Figure 39. I2S/SAI timing — slave modes

## 4 Dimensions

### 4.1 Obtaining package dimensions

Package dimensions are provided in package drawings.

To find a package drawing, go to [nxp.com](http://nxp.com) and perform a keyword search for the drawing's document number:

If you want the drawing for this package	Then use this document number
169-pin MAPBGA	98ASA00628D
210-pin WLCSP	98ASA01002D

For additional packaging assembly information on MAPBGA, refer to applications note AN4982.

For additional packaging assembly information on WLCSP, refer to applications note AN3846.

## 5 Pinout

## 5.1 K28F Signal Multiplexing and Pin Assignments

The signal multiplexing and pin assignments are provided in an Excel file attached to this document:

1. Click the paperclip symbol on the left side of the PDF window.
2. Double-click on the Excel file to open it.
3. Select the “Pinout” tab.

The Port Control Module is responsible for selecting which ALT functionality is available on each pin.

## 5.2 Recommended connection for unused analog and digital pins

Table 67 shows the recommended connections for analog interface pins if those analog interfaces are not used in the customer's application

**Table 67. Recommended connection for unused analog interfaces**

Pin Type	K28F	Short recommendation	Detailed recommendation
Analog/non GPIO	ADCx/CMPx	Float	Analog input - Float
Analog/non GPIO	VREF_OUT	Float	Analog output - Float
Analog/non GPIO	DAC0_OUT, DAC1_OUT	Float	Analog output - Float
Analog/non GPIO	RTC_WAKEUP_B	Float	Analog output - Float
Analog/non GPIO	XTAL32	Float	Analog output - Float
Analog/non GPIO	EXTAL32	Float	Analog input - Float
GPIO/Analog	PTA18/EXTAL0	Float	Analog input - Float
GPIO/Analog	PTA19/XTAL0	Float	Analog output - Float
GPIO/Analog	PTx/ADCx	Float	Float (default is analog input)
GPIO/Analog	PTx/CMPx	Float	Float (default is analog input)
GPIO/Digital	PTA0/JTAG_TCLK	Float	Float (default is JTAG with pulldown)
GPIO/Digital	PTA1/JTAG_TDI	Float	Float (default is JTAG with pullup)
GPIO/Digital	PTA2/JTAG_TDO	Float	Float (default is JTAG with pullup)
GPIO/Digital	PTA3/JTAG_TMS	Float	Float (default is JTAG with pullup)
GPIO/Digital	PTA4/NMI_b	10kΩ pullup or disable and float	Pull high or disable in PCR & FOPT and float
GPIO/Digital	PTx	Float	Float (default is disabled)
USB	USB0_DP	Float	Float

*Table continues on the next page...*

**Table 67. Recommended connection for unused analog interfaces (continued)**

Pin Type	K28F	Short recommendation	Detailed recommendation
USB	USB0_DM	Float	Float
USB	VREG_OUT	Tie to input and ground through 10 k $\Omega$	Tie to input and ground through 10 k $\Omega$
USB	VREG_IN0	Tie to output and ground through 10 k $\Omega$	Tie to output and ground through 10 k $\Omega$
USB	VREG_IN1	Tie to output and ground through 10 k $\Omega$	Tie to output and ground through 10 k $\Omega$
USB	USB1VSS	Always connect to VSS	Always connect to VSS
USB	USB1_DP	Float	Float
USB	USB1_DM	Float	Float
USB	USB_VBUS	Float	Float
V <sub>BAT</sub>	V <sub>BAT</sub>	Float	Float
VDDA	VDDA	Always connect to VDD potential	Always connect to VDD potential
VREFH	VREFH	Always connect to VDD potential	Always connect to VDD potential
VREFL	VREFL	Always connect to VSS potential	Always connect to VSS potential
VSSA	VSSA	Always connect to VSS potential	Always connect to VSS potential

### 5.3 K28F Pinouts

The pinout diagrams are provided in an Excel file attached to this document:

1. Click the paperclip symbol on the left side of the PDF window.
2. Double-click on the Excel file to open it.
3. Select the respective package tab.

Many signals may be multiplexed onto a single pin. To determine what signals can be used on which pin, see the previous section.

## 6 Ordering parts

## 6.1 Determining valid orderable parts

Valid orderable part numbers are provided on the web. To determine the orderable part numbers for this device, go to [nxp.com](http://nxp.com) and perform a part number search for the following device numbers: MK28.

## 7 Part identification

### 7.1 Description

Part numbers for the chip have fields that identify the specific part. You can use the values of these fields to determine the specific part you have received.

### 7.2 Format

Part numbers for this device have the following format:

Q K## A M FFF R T PP CC N

### 7.3 Fields

This table lists the possible values for each field in the part number (not all combinations are valid):

Field	Description	Values
Q	Qualification status	<ul style="list-style-type: none"> <li>M = Fully qualified, general market flow</li> <li>P = Prequalification</li> </ul>
K##	Kinetis family	<ul style="list-style-type: none"> <li>K28</li> </ul>
A	Key attribute	<ul style="list-style-type: none"> <li>D = Cortex-M4 w/ DSP</li> <li>F = Cortex-M4 w/ DSP and FPU</li> </ul>
M	Flash memory type	<ul style="list-style-type: none"> <li>N = Program flash only</li> <li>X = Program flash and FlexMemory</li> </ul>
FFF	Program flash memory size	<ul style="list-style-type: none"> <li>32 = 32 KB</li> <li>64 = 64 KB</li> <li>128 = 128 KB</li> <li>256 = 256 KB</li> <li>512 = 512 KB</li> <li>1M0 = 1 MB</li> <li>2M0 = 2 MB</li> </ul>

*Table continues on the next page...*

Field	Description	Values
R	Silicon revision	<ul style="list-style-type: none"> <li>• Z = Initial</li> <li>• (Blank) = Main</li> <li>• A = Revision after main</li> </ul>
T	Temperature range (°C)	<ul style="list-style-type: none"> <li>• V = -40 to 105</li> <li>• C = -40 to 85</li> </ul>
PP	Package identifier	<ul style="list-style-type: none"> <li>• FM = 32 QFN (5 mm x 5 mm)</li> <li>• FT = 48 QFN (7 mm x 7 mm)</li> <li>• LF = 48 LQFP (7 mm x 7 mm)</li> <li>• LH = 64 LQFP (10 mm x 10 mm)</li> <li>• MP = 64 MAPBGA (5 mm x 5 mm)</li> <li>• LK = 80 LQFP (12 mm x 12 mm)</li> <li>• LL = 100 LQFP (14 mm x 14 mm)</li> <li>• MC = 121 MAPBGA (8 mm x 8 mm)</li> <li>• LQ = 144 LQFP (20 mm x 20 mm)</li> <li>• MD = 144 MAPBGA (13 mm x 13 mm)</li> <li>• MI = 169 MAPBGA (9 mm x 9 mm)</li> <li>• AU = 210 WLCSP (6.9 mm x 6.9 mm)</li> </ul>
CC	Maximum CPU frequency (MHz)	<ul style="list-style-type: none"> <li>• 5 = 50 MHz</li> <li>• 7 = 72 MHz</li> <li>• 10 = 100 MHz</li> <li>• 12 = 120 MHz</li> <li>• 15 = 150 MHz</li> <li>• 18 = 180 MHz</li> </ul>
N	Packaging type	<ul style="list-style-type: none"> <li>• R = Tape and reel</li> <li>• (Blank) = Trays</li> </ul>

## 7.4 Example

This is an example part number:

MK28FN2M0AVMI15

## 8 Terminology and guidelines

### 8.1 Definitions

Key terms are defined in the following table:

Term	Definition
Rating	A minimum or maximum value of a technical characteristic that, if exceeded, may cause permanent chip failure:

*Table continues on the next page...*

## Terminology and guidelines

Term	Definition
	<ul style="list-style-type: none"> <li>• <i>Operating ratings</i> apply during operation of the chip.</li> <li>• <i>Handling ratings</i> apply when the chip is not powered.</li> </ul> <p><b>NOTE:</b> The likelihood of permanent chip failure increases rapidly as soon as a characteristic begins to exceed one of its operating ratings.</p>
Operating requirement	A specified value or range of values for a technical characteristic that you must guarantee during operation to avoid incorrect operation and possibly decreasing the useful life of the chip
Operating behavior	A specified value or range of values for a technical characteristic that are guaranteed during operation if you meet the operating requirements and any other specified conditions
Typical value	<p>A specified value for a technical characteristic that:</p> <ul style="list-style-type: none"> <li>• Lies within the range of values specified by the operating behavior</li> <li>• Is representative of that characteristic during operation when you meet the <a href="#">typical-value conditions</a> or other specified conditions</li> </ul> <p><b>NOTE:</b> Typical values are provided as design guidelines and are neither tested nor guaranteed.</p>

## 8.2 Examples

*Operating rating:*

Symbol	Description	Min.	Max.	Unit
V <sub>DD</sub>	1.0 V core supply voltage	-0.3	1.2	V

*Operating requirement:*

Symbol	Description	Min.	Max.	Unit
V <sub>DD</sub>	1.0 V core supply voltage	0.9	1.1	V

*Operating behavior that includes a typical value:*

Symbol	Description	Min.	Typ.	Max.	Unit
I <sub>WP</sub>	Digital I/O weak pullup/pulldown current	10	70	130	μA

### 8.3 Typical-value conditions

Typical values assume you meet the following conditions (or other conditions as specified):

Symbol	Description	Value	Unit
$T_A$	Ambient temperature	25	°C
$V_{DD}$	Supply voltage	3.3	V

### 8.4 Relationship between ratings and operating requirements

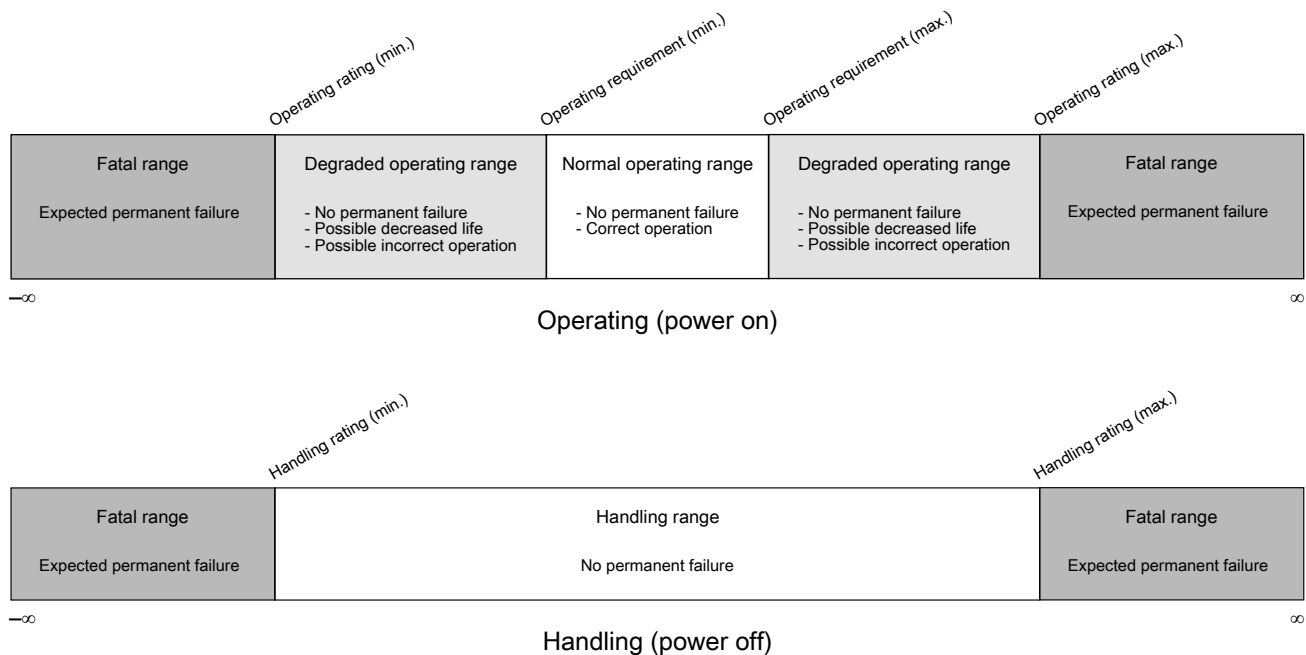

### 8.5 Guidelines for ratings and operating requirements

Follow these guidelines for ratings and operating requirements:

- Never exceed any of the chip's ratings.
- During normal operation, don't exceed any of the chip's operating requirements.
- If you must exceed an operating requirement at times other than during normal operation (for example, during power sequencing), limit the duration as much as possible.

## 9 Revision History

The following table provides a revision history for this document.

**Table 68. Revision History**

Rev. No.	Date	Substantial Changes
0	08/2017	Initial release

**How to Reach Us:**

**Home Page:**

[nxp.com](http://nxp.com)

**Web Support:**

[nxp.com/support](http://nxp.com/support)

Information in this document is provided solely to enable system and software implementers to use NXP products. There are no express or implied copyright licenses granted hereunder to design or fabricate any integrated circuits based on the information in this document. NXP reserves the right to make changes without further notice to any products herein.

NXP makes no warranty, representation, or guarantee regarding the suitability of its products for any particular purpose, nor does NXP assume any liability arising out of the application or use of any product or circuit, and specifically disclaims any and all liability, including without limitation consequential or incidental damages. "Typical" parameters that may be provided in NXP data sheets and/or specifications can and do vary in different applications, and actual performance may vary over time. All operating parameters, including "typicals," must be validated for each customer application by customer's technical experts. NXP does not convey any license under its patent rights nor the rights of others. NXP sells products pursuant to standard terms and conditions of sale, which can be found at the following address: [nxp.com/SalesTermsandConditions](http://nxp.com/SalesTermsandConditions).

NXP, the NXP logo, NXP SECURE CONNECTIONS FOR A SMARTER WORLD, Freescale, the Freescale logo, and Kinetis are trademarks of NXP B.V. All other product or service names are the property of their respective owners. ARM, the ARM powered logo, Thumb, and Cortex are registered trademarks of ARM Limited (or its subsidiaries) in the EU and/or elsewhere. All rights reserved.

© 2016–2017 NXP B.V.

Document Number K28P210M150SF5V2  
Revision 0, 08/2017

