

## AC/DC Secondary-Side Controller for Qualcomm® Quick Charge™ 3.0 USB Interface

### 1 Description

The iW636 is an AC/DC secondary-side controller for USB interface supporting Qualcomm Quick Charge 3.0 (QC3.0) technology and secondary-to-primary communication protocol, to enable rapid charging of QC3.0/QC2.0-enabled mobile devices (MDs). The iW636 resides on the secondary side of an AC/DC power supply and allows the adapter to be configured for multi-level output voltages from 3.6V to 12V in 200mV increments, depending on the voltage requested by the MD. It can be used in Dialog's primary-side controlled AC/DC systems to achieve fast voltage transition, low no-load power consumption, and fast dynamic load response.

The iW636 implements Dialog's proprietary secondary-to-primary digital communication technique. When paired with Dialog's primary-side iW1782 controller, the iW636 eliminates the discrete decoders on the primary side, simplifying system designs. It uses one opto-coupler to transmit all the necessary information for rapid charging, including output voltage requests, output current limits, output voltage undershoot, output over-voltage, and fault and reset signals. It also has a built-in opto-coupler LED driver to minimize the bill of material cost.

The iW636 and iW1782 provide double-layer cable protection. On the secondary side, the iW636 incorporates Dialog's proprietary D+/D- over-voltage protection to address  $V_{BUS}$  D+/D- soft shorts. On the primary side, the iW1782 uses Dialog's **SmartDefender™** advanced hiccup technology to reduce the average output power during soft shorts without latch.

Dialog's innovative, proprietary technology ensures that power supplies designed with the iW636 and iW1782 can provide multi-level output voltage configuration, with user-selected various output current limit combinations. Additionally, the chipset can achieve <10mW no-load power consumption at 5V, 2A output setting and fast dynamic load response in typical AC/DC rapid charge adapter designs.

### 2 Features

- Supports Qualcomm® Quick Charge™ 3.0 technology High Voltage Dedicated Charging Port (HVDCP) to provide  $V_{BUS}$  from 3.6V to 12V in 200mV increments
- Double-layer cable protection:
  - » Secondary side (iW636): Proprietary D+/D- over-voltage protection (OVP) addresses  $V_{BUS}$  D+/D- soft shorts
  - » Primary side (iW1782): **SmartDefender™** smart hiccup technology reduces average output power at fault conditions without latch
- Proprietary secondary-to-primary digital communication eliminates discrete decoders in the primary side and simplifies system designs
- Single opto-coupler transmits all information for rapid charge: output voltage requests, output current limits, output voltage undershoot (UV), over-voltage protection (OVP), and fault and reset signals
- Adaptive OVP/UV detection for most  $V_{BUS}$  levels
- Backward compatible with QC2.0 and USB Battery Charging Specification Revision 1.2 (USB BC1.2)
- Pin-to-pin compatible with iW626
- Programmable active fast discharge from a high voltage  $V_{BUS}$  level to 5V at MD unplug or upon request with built-in switch or external switch
- Normally OFF state with <150µA cut-off current during 5V steady-state operation to achieve <10mW overall system no-load power consumption
- Wide operating voltage range from 3V to 16V
- Built-in opto-coupler LED driver with minimum driving current of 2mA
- 6-lead SOT-23 package

### 3 Applications

- Rapid-charging AC/DC adapters for smart phones, tablets, and other portable devices



Qualcomm® Quick Charge™ 3.0 is a product of Qualcomm Technologies, Inc.

**AC/DC Secondary-Side Controller for Qualcomm® Quick Charge™ 3.0 USB Interface**

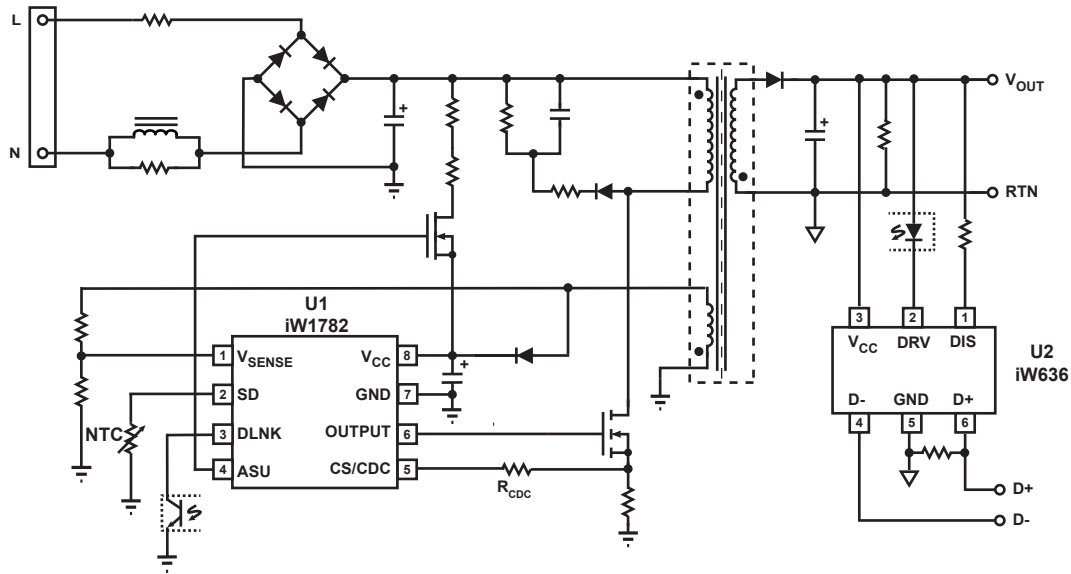

**Figure 3.1 : iW636 Typical Application Circuit for Multi-Level Output Voltage and Current (Using iW1782 as Primary-Side Controller. Achieving <10mW No-Load Power Consumption in a Typical 15W Design)**

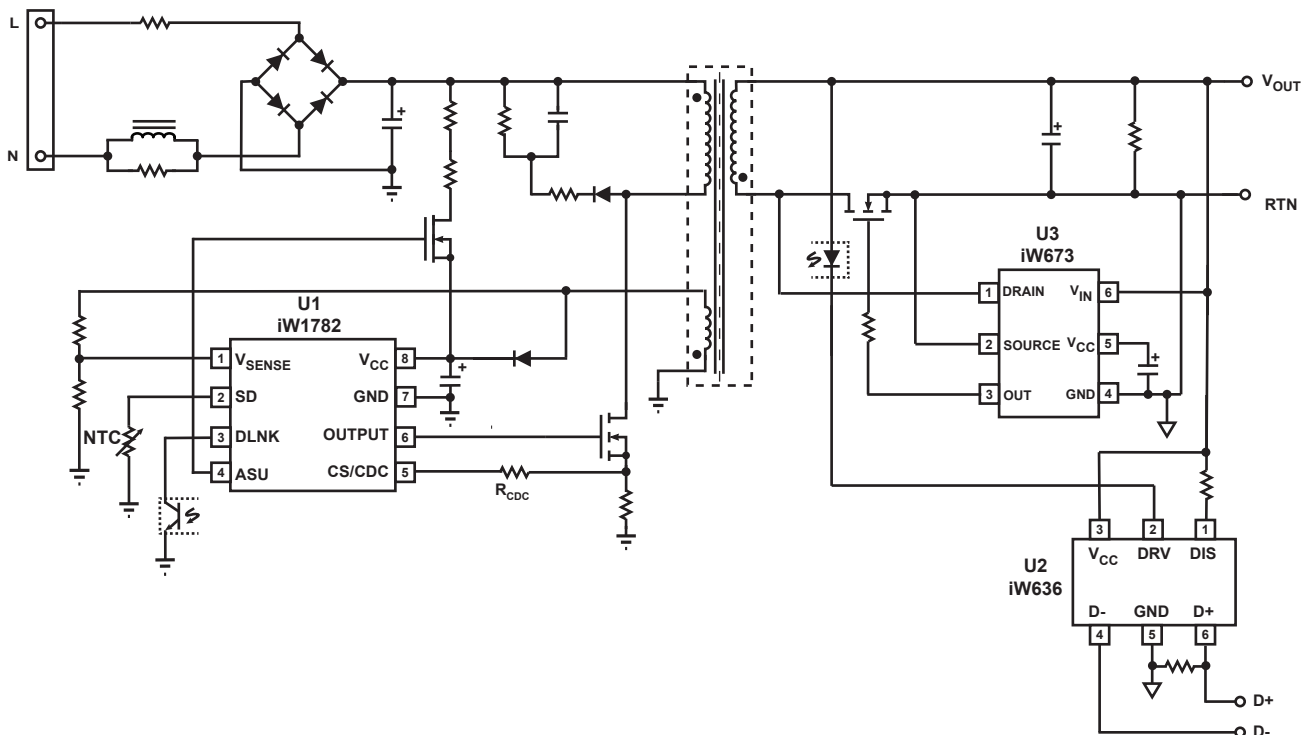

**Figure 3.2 : iW636 Typical Application Circuit for Multi-Level Output Voltage and Current (Using iW1782 as Primary-Side Controller and iW673 as Synchronous Rectifier Controller. for Higher Efficiency Achieving < 20mW No-Load Power Consumption in a Typical 15W Design)**

## AC/DC Secondary-Side Controller for Qualcomm® Quick Charge™ 3.0 USB Interface

### 4 Pinout Description

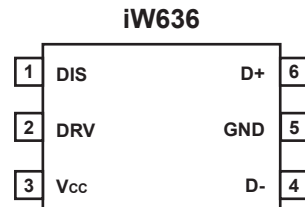

Figure 4.1 : 6-Lead SOT23 Package

Pin Number	Pin Name	Type	Pin Description
1	DIS	Analog Output	Discharging circuit. Used for fast discharging of output capacitor.
2	DRV	Analog Output	External circuit drive. Can be used for opto-coupler LED drive with automatic current limiting for transmitting signals to primary side.
3	V <sub>cc</sub>	Power Supply	IC power supply.
4	D-	Analog Input/ Output	USB D- signal.
5	GND	Ground	Ground.
6	D+	Analog Input	USB D+ signal.

## AC/DC Secondary-Side Controller for Qualcomm® Quick Charge™ 3.0 USB Interface

### 5 Absolute Maximum Ratings

Absolute maximum ratings are the parameter values or ranges which can cause permanent damage if exceeded.

Parameter	Symbol	Value	Units
DIS (pin 1) voltage	$V_{DIS}$	30	V
DRV (pin 2) voltage	$V_{DRV}$	30	V
$V_{CC}$ (pin 3) voltage	$V_{CC}$	30	V
D- (pin 4) voltage	$V_{D-}$	-0.3 to 7	V
D+ (pin 6) voltage	$V_{D+}$	-0.3 to 7	V
Continuous DC current at DRV pin ( $V_{DRV} = 11V$ )	$I_{DRV}$	25	mA
Continuous DC supply current at $V_{CC}$ pin ( $V_{CC} = 12V$ )	$I_{VCC}$	25	mA
Peak current at DIS pin ( $V_{DIS} = 12V$ )	$I_{DIS}$	600	mA
Maximum junction temperature	$T_{JMAX}$	150	°C
ESD rating per JEDEC JESD22-A114 (D+ and D- pins)		4,000	V
ESD rating per JEDEC JESD22-A114 (all other pins)		2,000	V

## AC/DC Secondary-Side Controller for Qualcomm® Quick Charge™ 3.0 USB Interface

### 6 Physical Dimensions

#### 6-Lead SOT Package

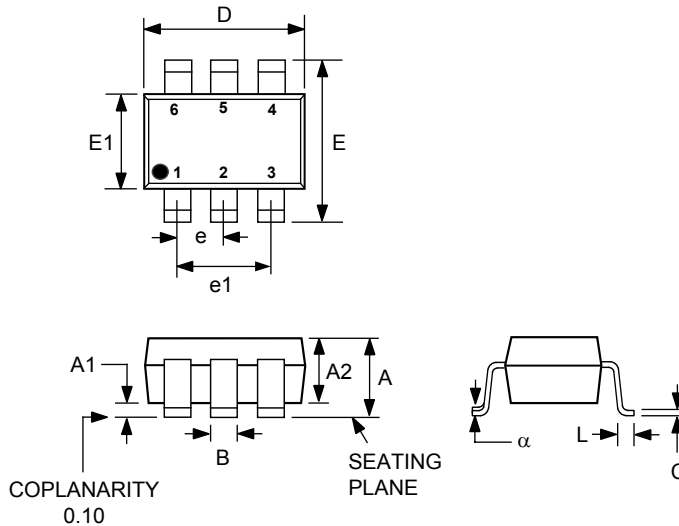

Symbol	Millimeters	
	MIN	MAX
A	-	1.45
A1	0.00	0.15
A2	0.90	1.30
B	0.30	0.50
C	0.08	0.22
D	2.90 BSC	
E	2.80 BSC	
E1	1.60 BSC	
e	0.95 BSC	
e1	1.90 BSC	
L	0.30	0.60
alpha	0°	8°

Compliant to JEDEC Standard MO-178AB

Controlling dimensions are in millimeters

This package is RoHS compliant and Halide free.

Soldering Temperature Resistance:

[a] Package is IPC/JEDEC Std 020D Moisture Sensitivity Level 1

[b] Package exceeds JEDEC Std No. 22-A111 for Solder Immersion Resistance; packages can withstand 10 s immersion < 260°C

Dimension D does not include mold flash, protrusions or gate burrs. Mold flash, protrusions or gate burrs shall not exceed 0.25 mm per side.

The package top may be smaller than the package bottom. Dimensions D and E1 are determined at the outermost extremes of the plastic body exclusive of mold flash, tie bar burrs and interlead flash, but including any mismatch between top and bottom of the plastic body.

## AC/DC Secondary-Side Controller for Qualcomm® Quick Charge™ 3.0 USB Interface

### 7 Ordering Information

Part Number	Options				Package	Description
	Supported Protocol	V <sub>BUS</sub> Range	k <sub>CC</sub>	OVP Threshold if Non-QC-Equipped MD is Attached		
iW636-00	QC3.0	3.6V to 12V	0.5 for V <sub>BUS</sub> =3.6V to 6V; Determined by constant max power for 6.2V to 12V	N/A	SOT-23	Tape & Reel <sup>1</sup>
iW636-02	QC3.0	3.6V to 12V	0.5 for V <sub>BUS</sub> =3.6V to 6.8V; Determined by constant max power for 7V to 12V	N/A	SOT-23	Tape & Reel <sup>1</sup>
iW636-04	QC3.0	3.6V to 12V	0.422 for V <sub>BUS</sub> =3.6V to 9V; Determined by constant max power for 9.2V to 12V	N/A	SOT-23	Tape & Reel <sup>1</sup>
iW636-05	QC3.0	3.6V to 12V	0.422 for V <sub>BUS</sub> =3.6V to 9V; Determined by constant max power for 9.2V to 12V	14.76V	SOT-23	Tape & Reel <sup>1</sup>
iW636-06	QC3.0	3.6V to 12V	0.422 for V <sub>BUS</sub> =3.6V to 8V; Determined by constant max power for 8.2V to 12V	14.76V	SOT-23	Tape & Reel <sup>1</sup>
iW636-07	QC3.0	3.6V to 12V	0.5 for V <sub>BUS</sub> =3.6V to 6V; Determined by constant max power for 6.2V to 12V	14.76V	SOT-23	Tape & Reel <sup>1</sup>
iW636-08	QC3.0	3.6V to 12V	0.5 for V <sub>BUS</sub> =3.6V to 8V; Determined by constant max power for 8.2V to 12V	14.76V	SOT-23	Tape & Reel <sup>1</sup>
iW636-21	QC3.0	3.6V to 9V	0.422 for V <sub>BUS</sub> =3.6V to 9V	11V	SOT-23	Tape & Reel <sup>1</sup>

**Note 1: Tape & Reel packing quantity is 3,000/reel. Minimum ordering quantity is 3,000.**

## AC/DC Secondary-Side Controller for Qualcomm® Quick Charge™ 3.0 USB Interface

Company Confidential

### Disclaimer

Information in this document is believed to be accurate and reliable. However, Dialog Semiconductor does not give any representations or warranties, expressed or implied, as to the accuracy or completeness of such information. Dialog Semiconductor furthermore takes no responsibility whatsoever for the content in this document if provided by any information source outside of Dialog.

Dialog Semiconductor reserves the right to change without notice the information published in this document, including without limitation the specification and the design of the related semiconductor products, software and applications.

Applications, software, and semiconductor products described in this document are for illustrative purposes only. Dialog makes no representation or warranty that such applications, software and semiconductor products will be suitable for the specified use without further testing or modification. Unless otherwise agreed in writing, such testing or modification is the sole responsibility of the customer and Dialog excludes all liability in this respect.

Customer notes that nothing in this document may be construed as a license for customer to use the Dialog products, software and applications referred to in this document. Such license must be separately sought by customer with Dialog Semiconductor.

All use of Dialog Semiconductor products, software and applications referred to in this document are subject to [Dialog Semiconductor's Standard Terms and Conditions of Sale](#), available on the company website ([www.dialog-semiconductor.com](http://www.dialog-semiconductor.com)) unless otherwise stated.

Dialog and the Dialog logo are trademarks of Dialog Semiconductor plc or its subsidiaries. All other product or service names are the property of their respective owners.

Qualcomm is a trademark of Qualcomm Incorporated, registered in the United States and other countries. Qualcomm Quick Charge is a trademark of Qualcomm Incorporated. All Qualcomm Incorporated marks are used with permission.

© Copyright 2016 Dialog Semiconductor. All rights reserved.

### RoHS Compliance

Dialog Semiconductor complies to European Directive 2001/95/EC and from 2 January 2013 onwards to European Directive 2011/65/EU concerning Restriction of Hazardous Substances (RoHS/RoHS2).

Dialog Semiconductor's statement on RoHS can be found on the customer portal <https://support.diasemi.com/>. RoHS certificates from our suppliers are available on request.

## Contacting Dialog Semiconductor

#### United Kingdom

Dialog Semiconductor (UK) Ltd  
Phone: +44 1793 757700

#### Germany

Dialog Semiconductor GmbH  
Phone: +49 7021 805-0

#### The Netherlands

Dialog Semiconductor B.V.  
Phone: +31 73 640 88 22

#### Email

[info\\_pcbg@diasemi.com](mailto:info_pcbg@diasemi.com)

#### North America

Dialog Semiconductor Inc.  
Phone: +1 408 845 8500

#### Japan

Dialog Semiconductor K. K.  
Phone: +81 3 5425 4567

#### Taiwan

Dialog Semiconductor Taiwan  
Phone: +886 281 786 222

#### Web site:

[www.dialog-semiconductor.com](http://www.dialog-semiconductor.com)

#### Singapore

Dialog Semiconductor Singapore  
Phone: +65 648 499 29

#### Hong Kong

Dialog Semiconductor Hong Kong  
Phone: +852 2607 4271

#### Korea

Dialog Semiconductor Korea  
Phone: +82 2 3469 8200

#### China

Dialog Semiconductor  
(Shenzhen)  
Phone: +86 755 2981 3669

Dialog Semiconductor  
(Shanghai)

Phone: +86 21 5424 9058