

Features

- Combined Protection Technology (CPT) design
- Common mode filter
- ESD protection
- Fast response time
- Low capacitance
- RoHS compliant*

Applications

- USB 2.0
- HDMI
- MIPI
- MHL

ChipGuard® Model CGF0804TFH-R900-2L ESD/EMI Filter

Description

The Bourns® ChipGuard® CGF Series utilizes Combined Protection Technology (CPT) to create an ESD protection device and common mode filter in a single space-saving device. This series features very low capacitance and superior common mode noise rejection, making it ideal for use in high-speed differential data lines.

Absolute Maximum Ratings @ 25 °C (unless otherwise noted)

Parameter	Symbol	Rating	Unit
Maximum DC Operating Voltage	V_{DC}	5	V
Maximum DC Operating Current	I_{DC}	100	mA
Operating Temperature Range	T_{OPR}	-40 to +85	°C
Storage Temperature Range	T_{STG}	-40 to +85	°C
ESD Protection per IEC 61000-4-2			
Contact Discharge		8	kV
Air Discharge		15	

Electrical Characteristics @ 25 °C (unless otherwise noted)

Parameter	Min.	Typ.	Max.	Unit
Common Mode Impedance @ 100 MHz	67.5	90	112.5	Ohms
Cut-off Frequency		3		GHz
DC Resistance	1.8	2.7	3.5	Ohms
Insulation Resistance	10			Megohms
Capacitance @ 1 MHz, Any Pin to Ground		0.6		pF
Leakage Current @ 5 V, Any Pin to Ground			1	μ A

Circuit Diagram

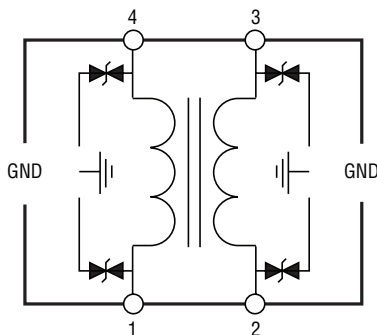

How to Order

CG F 0804 TFH - R900 - 2L

ChipGuard®
 Product Designator
 Common Mode Filter Designator
 Package
 0804 = 0804 Size
 Technology
 TFH = Thin Film High-Speed
 Common Mode Impedance @ 100 MHz
 R900 = 90 Ohms
 Lines
 2L = 2 Lines

Environmental Characteristics

Moisture Sensitivity Level..... 1
 ESD Classification (HBM)..... 6

BOURNS®

Asia-Pacific:

Tel: +886-2 2562-4117

Email: asiacus@bourns.com

Europe:

Tel: +36 88 520 390

Email: eurocus@bourns.com

The Americas:

Tel: +1-951 781-5500

Email: americus@bourns.com

www.bourns.com

*RoHS Directive 2015/863, Mar 31, 2015 and Annex.

Specifications are subject to change without notice.

The device characteristics and parameters in this data sheet can and do vary in different applications and actual device performance may vary over time. Users should verify actual device performance in their specific applications.

Impedance vs. Frequency Characteristics

Test Instrument: HP4291A Impedance/Material Analyzer

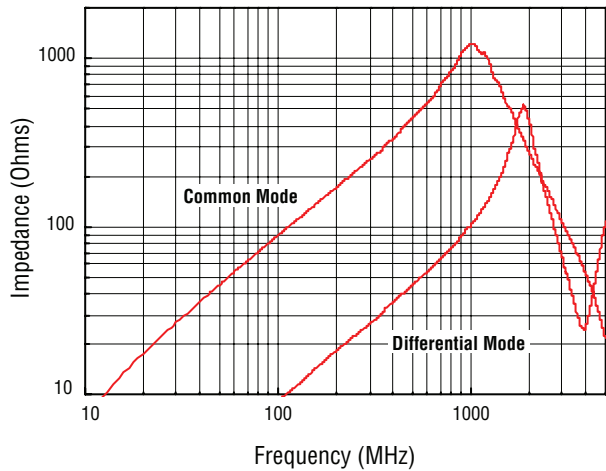

Insertion Loss vs. Frequency Characteristics

Test Instrument: Agilent E4071C ENA-L Network Analyzer

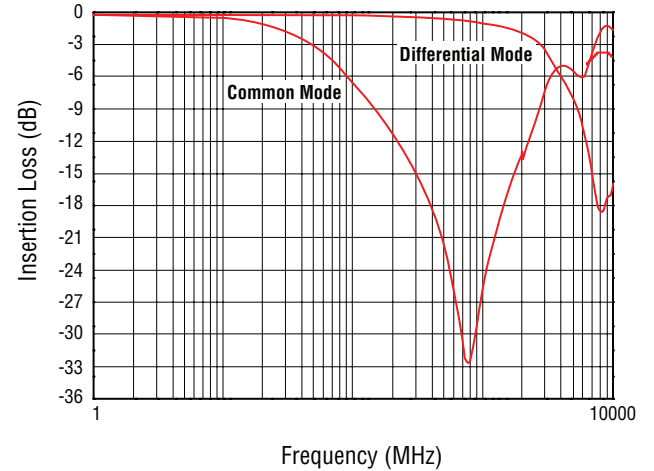

Product Dimensions

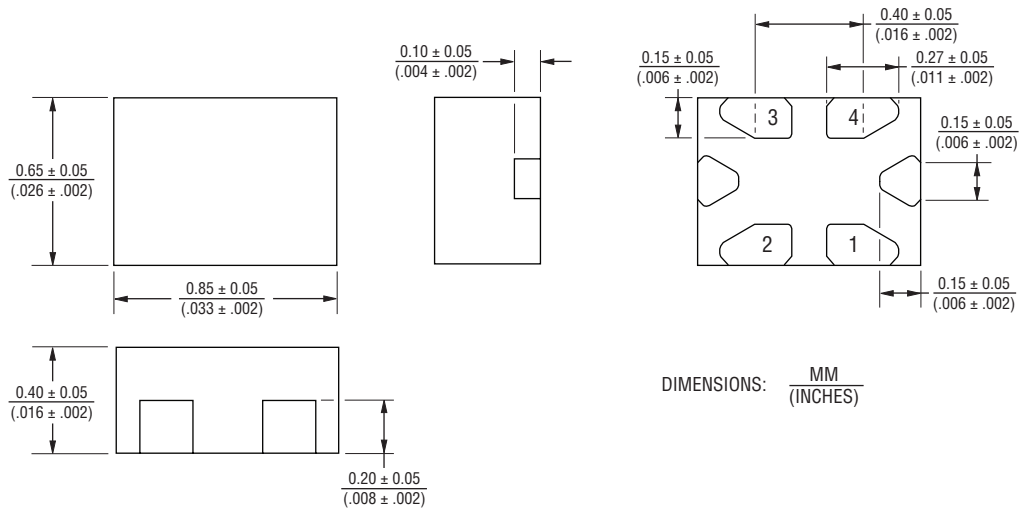

Specifications are subject to change without notice. The device characteristics and parameters in this data sheet can and do vary in different applications and actual device performance may vary over time. Users should verify actual device performance in their specific applications.

Solder Reflow Recommendations

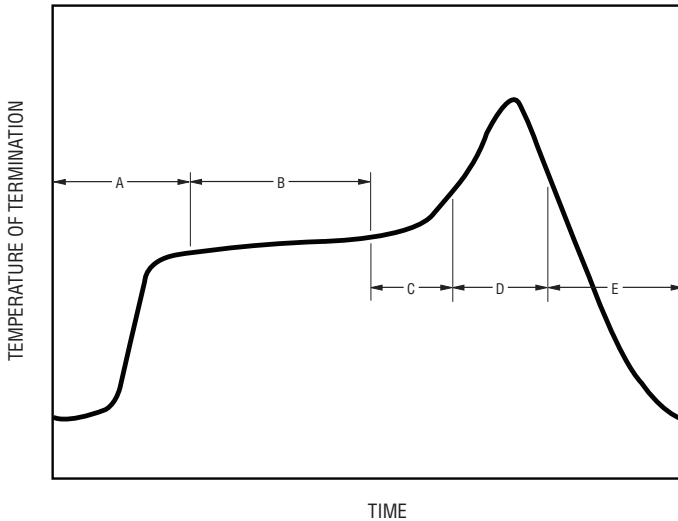

A	1st Rising Temperature	The Normal to Preheating Temperature	30 s to 60 s
B	Preheating	140 °C to 160 °C	60 s to 120 s
C	2nd Rising Temperature	Preheating to 200 °C	20 s to 40 s
D	Main Heating	if 220 °C if 230 °C if 240 °C if 250 °C if 260 °C	50 s ~ 60 s 40 s ~ 50 s 30 s ~ 40 s 20 s ~ 40 s 20 s ~ 40 s
E	Regular Cooling	200 °C to 100 °C	1 °C/s ~ 4 °C/s

Per J-STD-020C

Packaging Dimensions

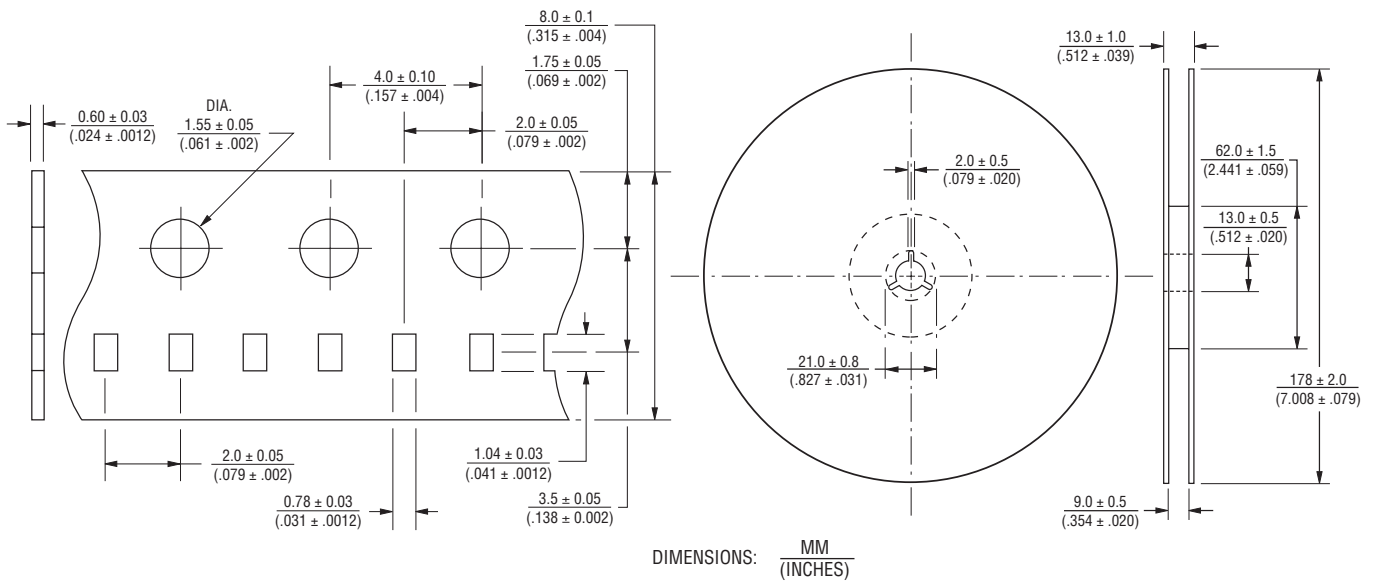

DIMENSIONS: $\frac{\text{MM}}{\text{(INCHES)}}$

STANDARD = 10,000 pieces per reel