

MA600ERUI Series

Wide 4:1 Input, 6W, High Isolation, DIP DC/DC Converters



Key Features:

- 6W Output Power
- 4:1 Input Voltage Range
- 3,000 VDC Isolation
- Eight Standard Models
- Efficiency to 88%
- Compact DIP Case
- -40°C to +85°C Operation
- Industry Standard Pin-Out
- Low Cost

RoHS



Electrical Specifications

Specifications typical @ +25°C, nominal input voltage & rated output current, unless otherwise noted. Specifications subject to change without notice.

Input

Parameter	Conditions	Min.	Typ.	Max.	Units
Input Voltage Range	24 VDC Input	9.0	24.0	36.0	VDC
	48 VDC Input	18.0	48.0	75.0	
Input Start Voltage	24 VDC Input			9.0	VDC
	48 VDC Input			18.0	
Input Filter	π (Pi) Filter				
No Load Input Power			0.2	0.5	W

Output

Parameter	Conditions	Min.	Typ.	Max.	Units
Output Voltage Accuracy	I _{OUT} = 5% to 100%		±1.0	±2.0	%
Line Regulation	V _{IN} = Min to Max		±0.2	±0.5	%
Load Regulation	I _{OUT} = 5% to 100%		±0.5	±1.0	%
Ripple (20 MHz)	See Note 1		15	30	mV P - P
Noise (20 MHz), See Note 1	24 VDC Input		65	100	mV P - P
	48 VDC Input		85	150	
Transient Recovery Time, See Note 2	25% Load Step Change		300	500	μSec
Transient Response Deviation			±3.0	±5.0	%
Temperature Coefficient				±0.03	%/°C
Output Over Voltage Protection		110	120	140	%
Output Short Circuit, See Note 3	Continuous (Autorecovery)				

General

Parameter	Conditions	Min.	Typ.	Max.	Units
Isolation Voltage	60 Seconds	3,000			VDC
Isolation Resistance	500 VDC	1,000			MΩ
Isolation Capacitance	100 kHz/0.1V		120		pF
Switching Frequency			330		kHz

EMI Characteristics

Parameter	Standard	Level
Radiated Emissions	See Note 4 EN 55022	Class A
Conducted Emissions	See Note 4 EN 55022	Class A
ESD	EN 61000-4-2	Criteria B; ±4 kV Contact
RS	EN 61000-4-3	Criteria A; 10V/m
EFT	See Note 5 EN 61000-4-4	Criteria B; ±2 kV
Surge	See Note 5 EN 61000-4-4	Criteria B; ±4 kV
CS	See Note 6 EN 61000-4-5	Criteria B; ±2 kV
Voltage Dips	EN 61000-4-6 EN 61000-4-29	Criteria A; 3 Vrms Criteria B; 0% - 70%

Environmental

Parameter	Conditions	Min.	Typ.	Max.	Units
Operating Temperature Range	Ambient	-40	+25	+85	°C
Operating Temperature Range	Case			+105	°C
Storage Temperature Range		-55		+125	°C
Cooling	Free Air Convection				
Humidity	RH, Non-condensing			95	%

Physical

Case Size	1.244 x 0.799 x 0.402 Inches (31.60 x 20.30 x 10.20 mm)
Case Material	Non-Conductive Black Plastic (UL94-V0)
Weight	0.46 Oz (13g)

Reliability Specifications

Parameter	Conditions	Min.	Typ.	Max.	Units
MTBF	MIL HDBK 217F, 25°C, Gnd Benign	1.0			MHours

Absolute Maximum Ratings

Parameter	Conditions	Min.	Typ.	Max.	Units
Input Voltage Surge (1 Sec)	24 VDC Input	-0.7		50.0	VDC
	48 VDC Input	-0.7		100.0	
Lead Temperature	1.5 mm From Case for 10 Sec			300	°C

Caution: Exceeding Absolute Maximum Ratings may damage the module. These are not continuous operating ratings.

MicroPower Direct

292 Page Street
Suite D
Stoughton, MA 02072
USA

T: (781) 344-8226
F: (781) 344-8481
E: sales@micropowerdirect.com
W: www.micropowerdirect.com



www.micropowerdirect.com

Model Number	Input				Output			Efficiency (% Typ)	Reflected Ripple Current (mA Typ)	Capacitive Load (μ F, Max)	Fuse Rating Slow-Blow (mA)
	Voltage (VDC)		Current (mA)		Voltage (VDC)	Current (mA, Max)	Current (mA, Min)				
	Nominal	Range	Full-Load	No-Load							
MA624S-05ERUI	24	9.0 - 36.0	301	12	5.0	1,200	60	83	20.0	2,200	2,000
MA624S-12ERUI	24	9.0 - 36.0	287	12	12.0	500	25	87	20.0	680	2,000
MA624S-15ERUI	24	9.0 - 36.0	284	12	15.0	400	20	88	20.0	680	2,000
MA624S-24ERUI	24	9.0 - 36.0	287	12	24.0	250	12	87	20.0	680	2,000
MA648S-05ERUI	48	18.0 - 75.0	151	3	5.0	1,200	60	83	20.0	2,200	1,000
MA648S-12ERUI	48	18.0 - 75.0	143	3	12.0	500	25	87	20.0	680	1,000
MA648S-15ERUI	48	18.0 - 75.0	142	3	15.0	400	20	88	20.0	680	1,000
MA648S-24ERUI	48	18.0 - 75.0	143	3	24.0	250	12	87	20.0	680	1,000

Notes:

- When measuring output ripple & noise, it is recommended that an external capacitor (1 μ F to 10 μ F) be placed from the +Vout to the -Vout pins.
- Transient recovery is measured to within a 1% error band for a load step change of 25%.
- Short circuit protection is provided by a "hiccup mode" circuit.
- All units are rated for EN 55022 (CE/RE) class A without external components. They will meet class B with the addition of the **DCFM-0x** (or a similar discrete filter circuit as shown on page 3). Contact the factory for more information.
- To meet the requirements of EN 61000-4-4 (\pm 2 kV), external components are needed, as shown on page 3. With the addition of the **DCFM-0x**, EN 61000-4-4 (\pm 4 kV) can be achieved. Contact the factory for more information.
- To meet the requirements of EN 61000-4-5 (\pm 2 kV), external components are needed. This can be done discretely (as shown on page 3), or with the addition of the **DCFM-0x**. Contact the factory for more information.
- These units should not be operated with a load under 5% of full load. Operation at no-load will not damage the unit, but they may not meet all specifications.
- It is recommended that a fuse be used on the input of a power supply for protection. See the Model Selection table above for the correct rating.

Derating Curve

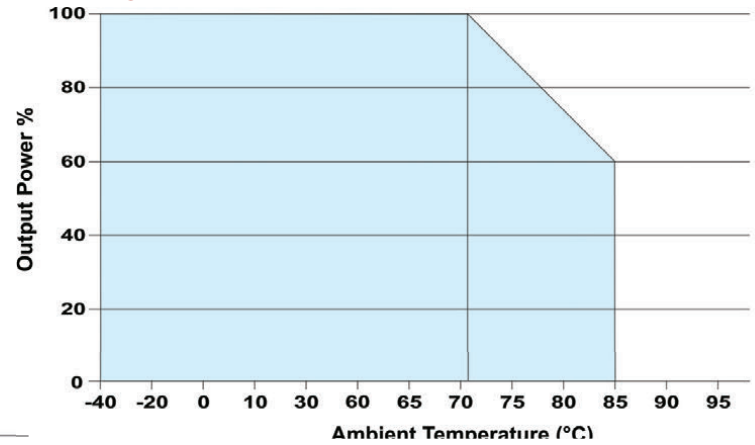

Efficiency vs Input Voltage 24 VDC Input

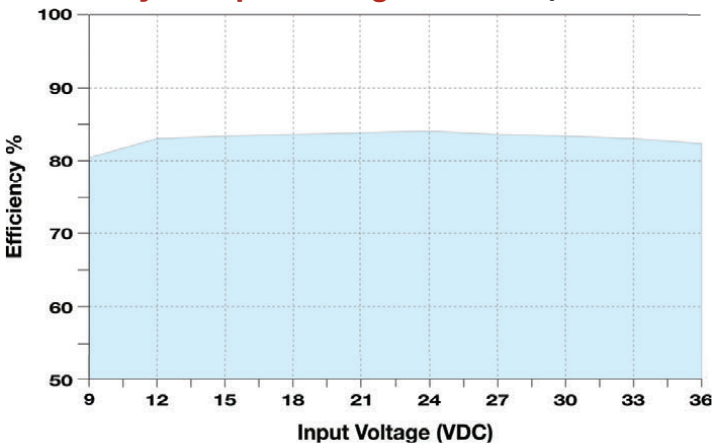

Efficiency vs Output Load 24 VDC Input

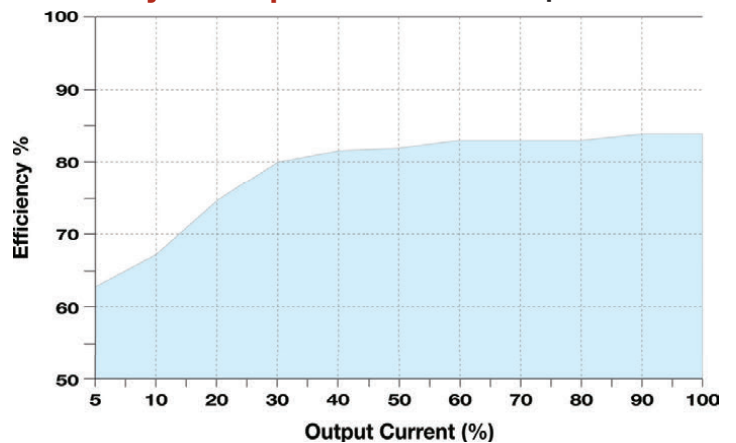

Efficiency vs Input Voltage 48 VDC Input

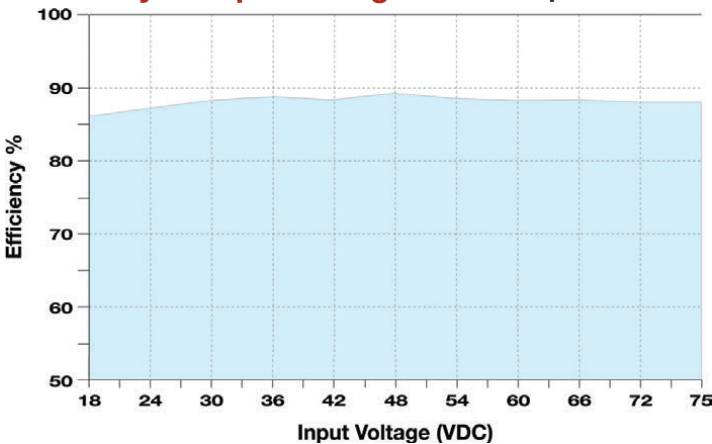

Efficiency vs Output Load 48 VDC Input

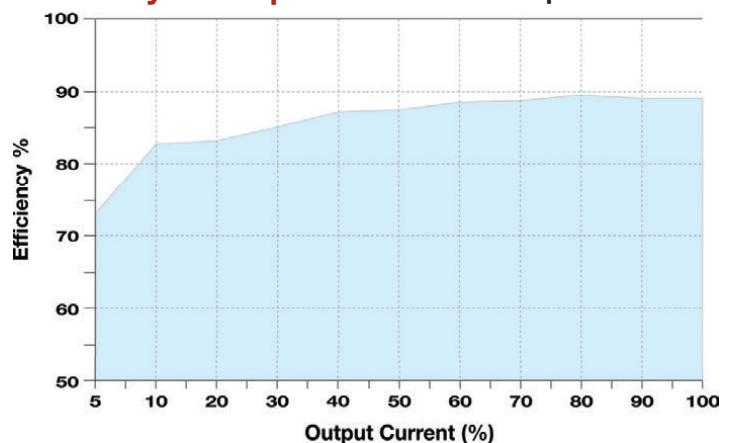

Typical Connection

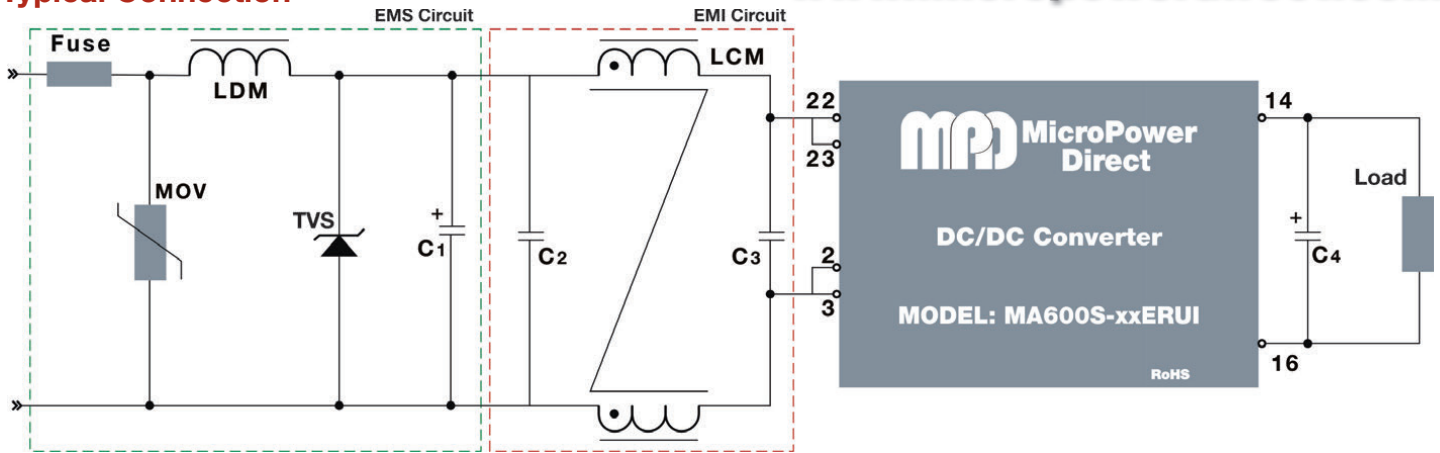

The diagram above illustrates a typical connection of the **MA600ERUI** series for applications that require meeting EMC standards. The units do not require external components to operate as specified. Some notes on this diagram (starting with the input circuit) are:

1. It is recommended that an external fuse be used. The recommended fuse is shown in the model chart on page 2.
2. An external MOV is recommended on the input to protect the unit in the event of a surge. A recommended value is given in the table at right.
3. An external TVS is recommended on the input to protect the unit in the event of a voltage spike. A recommended value is given in the table at right.
4. The output filtering capacitor (C₄) is a low ESR electrolytic capacitor. Care must be taken in choosing this capacitor not to exceed the capacitive load specification for the unit. Voltage derating of capacitors should be 80% or above.

5. Recommended values for components are:

Component	24 V _{IN}	48 V _{IN}
MOV	S14K35	S14K60
LDM	56 μH	56 μH
TVS	SMCJ48A	SMCJ90A
C ₁	330 μF/50V	330 μF/100V
C ₂ , C ₃	2.2 μF/50V	2.2 μF/100V
LCM	2.2 mH	2.2 mH
C ₄	10 μF	10 μF

6. The drawing below shows a suggested board layout for the EMC/EMI circuit shown above. Filtering capacitor (C₄) is a low ESR resistance electrolytic capacitor. Care must be taken in choosing this capacitor not to exceed the capacitive load specification for the unit.

7. In many applications simply adding input/output capacitors will enhance the input surge protection and reduce output ripple sufficiently. Typically, the value of the input capacitor should be > 330 μF. The output capacitor would be 10 μF.

Typical Board Layout: With External Filter/Surge Components

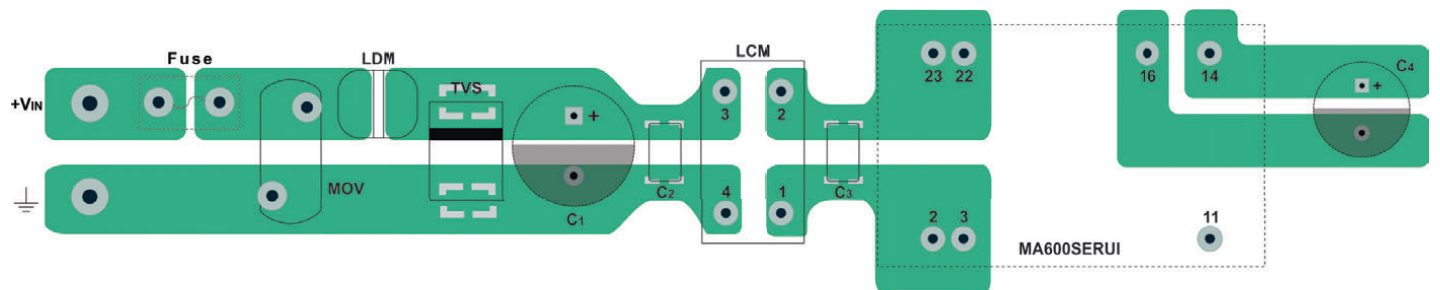

Input noise and surge suppression modules are available for a number of MPD DC/DC power supplies. An **MA600ERUI** connection with the **DCFM-02** (noise suppression) module connected to the input is shown below.

The recommended input capacitor (C₁) is a 330 μF/50V for 24 VDC input models and 330 μF/100V for 48 VDC input units. The output capacitor would be 10 μF.

For pricing or full technical information on these modules (**DCFM-01**, **DCFM-02** and **DCFM-03**) please contact the factory.

Typical Connection: With DCFM-0x ISurge Suppression and Filter Module

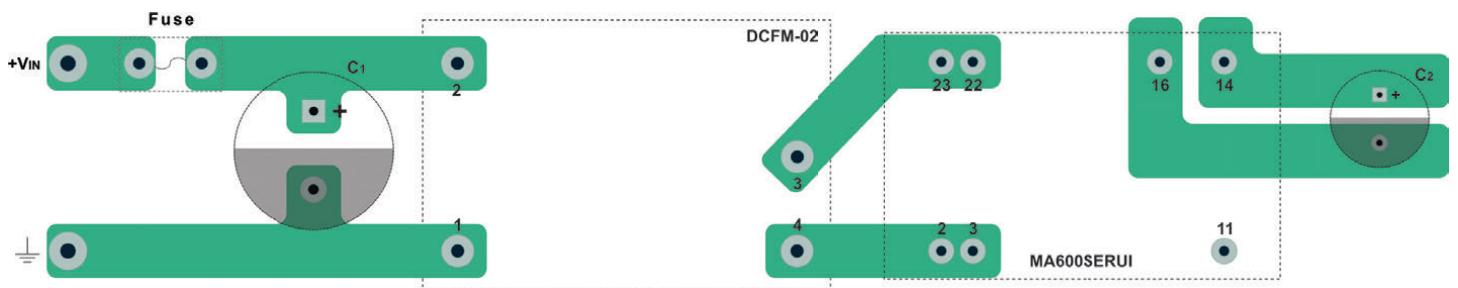

Mechanical Dimensions

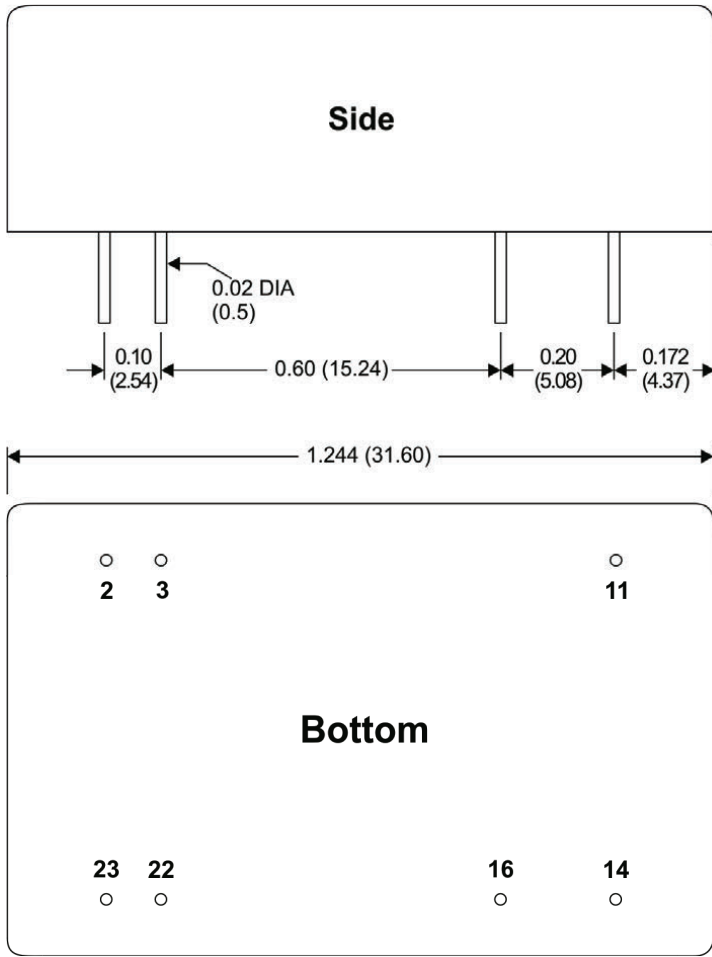

Pin Connections

Pin	Single Output
2	-Vin
3	-Vin
11	No Connection
14	+Vout
16	-Vout
22	+Vin
23	+Vin

Notes:

- All dimensions are typical in inches (mm)
- Tolerance x.xx = ±0.02 (±0.50)
- Pin 1 is marked by a "dot" or indentation on the top of the unit

Packing Tube Dimensions

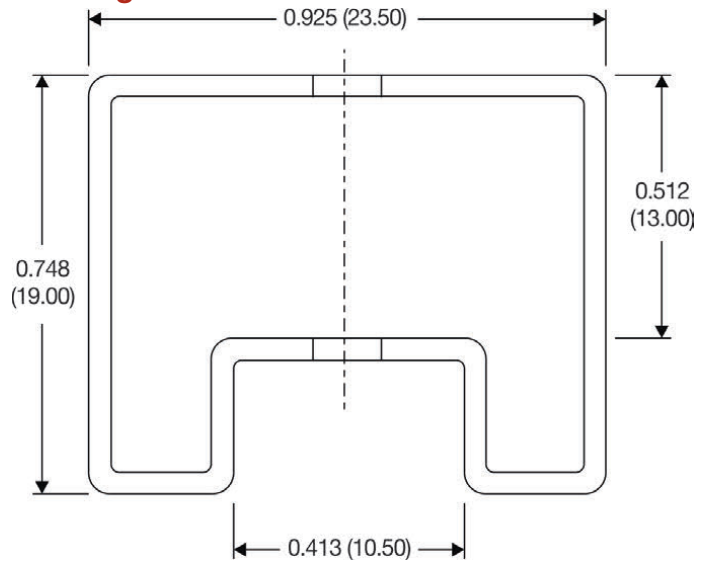

Notes:

- Tube length equals 20.866 (530), unit quantity equals 15 pcs.
- Tube length equals 8.661 (220), unit quantity equals 6 pcs.
- All dimensions are typical in inches (mm)
- Tolerance x.xx = ±0.02 (±0.50)



MicroPower Direct

We Power Your Success - For Less!