

FEATURES

- 16mm square compact size
- Excellent click & switch feelings
- Long life of 2 million cycles

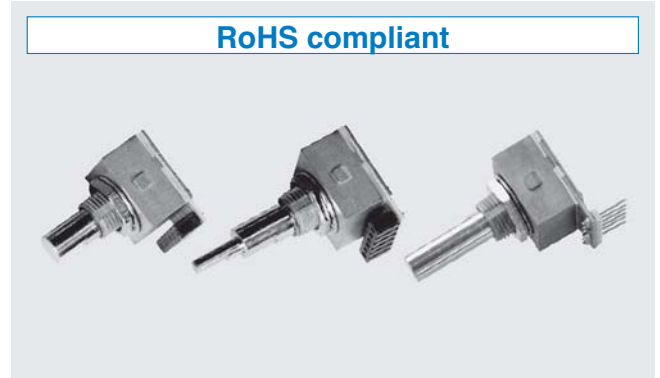

PART NUMBER DESIGNATION

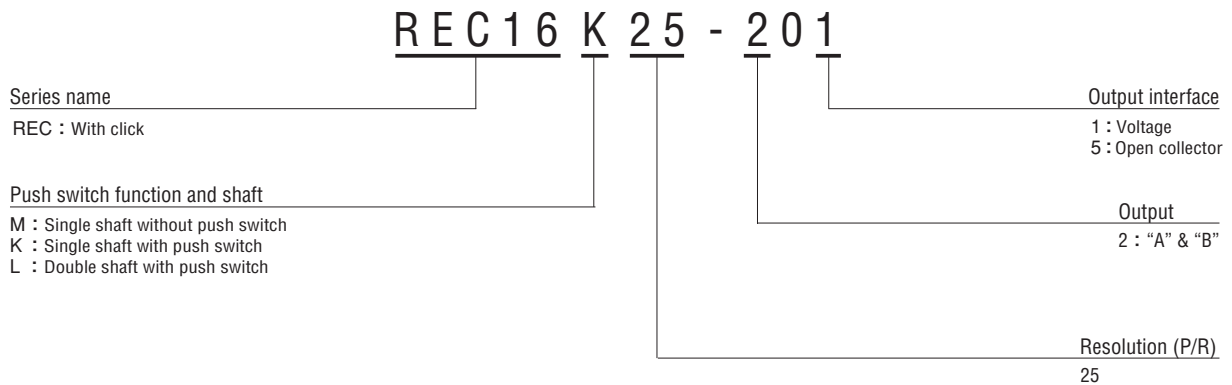

LIST OF PART NUMBERS

Resolution	Click	Push switch function	Shaft	Output interface	Part number
25 (P/R)	With Click	No	Single Shaft	Voltage (PIN HEADER Type)	REC16M25-201
		Yes		Double Shaft	Open Collector (SCOKET Type)

The products indicated by ➡ mark are manufactured upon receipt of order basis.

REC16K/REC16L/REC16M

OPTICAL ENCODERS

STANDARD SPECIFICATIONS

Electrical characteristics

Input voltage	DC5 ± 5 %	
Input current	30 mA maximum	
Output wave form	Square wave	
Output phases	A, B	
(P/R) Resolution	25	
Phase difference of outputs A & B	90° ± 45°	
Maximum frequency response	100 Hz	
Output signal	"1 (High)"	+ 4.5 V minimum
	"0 (Low)"	+ 0.5 V maximum
Light source	LED	

Switch characteristics

Maximum contact rating	DC15 V, 20 mA
Contact resistance	2 Ω maximum (Initial value)

Note) Manual setting only.

Mechanical characteristics

Click torque	7.35 mN·m ± 2.5 maximum (75 ± 25 gf·cm) <REC : With click>	
Click number	25	
Shaft loading (Pull-push)	19.6 N maximum (2 kgf)	
Switch operation force	2.45 ± 1.47 N (250 ± 150 gf)	
Switch stroke	0.3 ± 0.2 mm	
Rotational life (Mechanical)	2 million cycles	
Switching life	1 million cycles	
Shaft loading (When mounting)	Radial	4.90 N maximum (500 gf)
	Axial	2.94 N maximum (300 gf)
Net weight	Approx. 12 g	
Strength of tighten screw	1 N·m {10.2 kgf·cm} maximum	

Environmental characteristics

Operating temp. range	0 ~ 50 °C
Storage temp. range	-20 ~ 80 °C
Protection grade	IP40

OUTPUT

Click spot for 25P/R

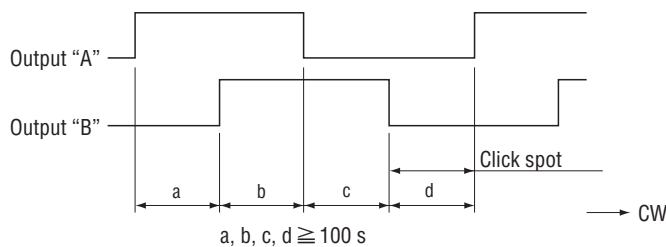

The click spot is located somewhere outputs A & B are at Lo level.

REC16K/REC16L/REC16M

OPTICAL ENCODERS

RELIABILITY TEST

The output shall satisfy the criteria below after the following tests.

Test item		Test conditions
Vibration	Power OFF	Amplitude : 1.52 mm or 98.1 m/s ² (10 G) whichever is smaller. 10 ~ 500 Hz excursion 15 min/cycle, 8 cycles each for X, Z, directions.
Shock	Power OFF	3 times each in directions (X, Z) at 490 m/s ² (50 G), 11 ms.
High temperature exposure	Power OFF	80 °C 96 h
	Power ON	50 °C 96 h
Low temperature exposure	Power OFF	- 20 °C 96 h
	Power ON	0 °C 96 h
Humidity	Power OFF	40 °C Relative humidity 90 ~ 95 % 96 h (To be measured after wiping out moisture and leaving samples for 1 h at normal temperature and humidity after the test.)
Thermal shock	Power OFF	To be done 10 cycles with the following condition (To be measured after leaving samples for 1 h at normal temperature and humidity after the test.) 80 °C 0.5 h, - 20 °C 0.5 h

OUTLINE DIMENSIONS

Unless otherwise specified, tolerance: ± 0.4 (Unit: mm)

Single shaft and PIN HEADER

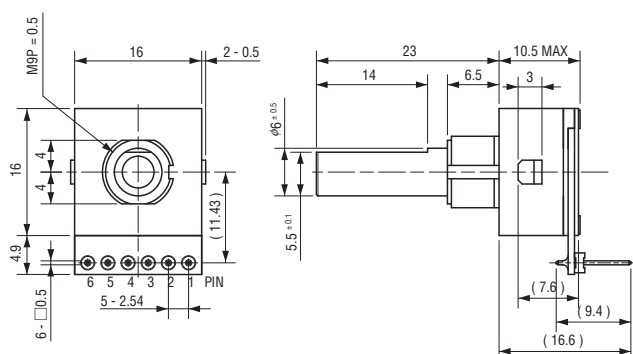

PIN HEADER :
Made by IRISO ELECTRONICS CO.,LTD
S208B - 1 - 6Z032 - PT1

< Accessories >

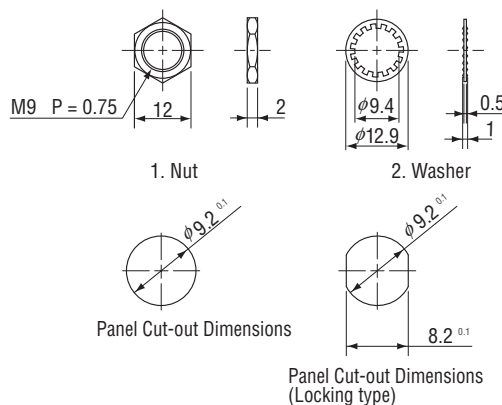

PIN ASSIGNMENT

Pin No.	Without switch	With switch
1	Power 0 (V)	Power 0 (V)
2	N C	For switch
3	N C	For switch
4	Output "B"	Output "B"
5	Output "A"	Output "A"
6	Power + 5V	Power + 5V

OUTPUT CIRCUITRY AND RECEIVING CIRCUITRY

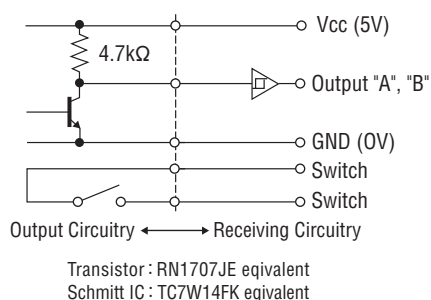

REC16K/REC16L/REC16M

OPTICAL ENCODERS

OUTLINE DIMENSIONS

Unless otherwise specified, tolerance: ± 0.4 (Unit: mm)

Single shaft and SOCKET

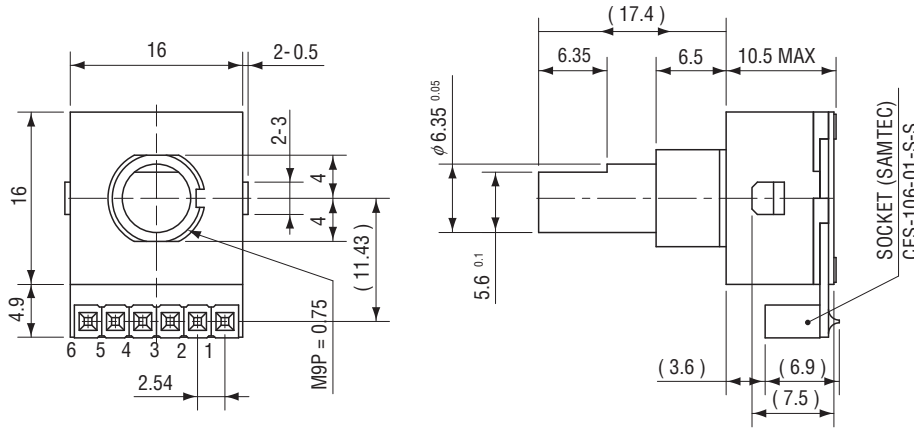

<Accessories>

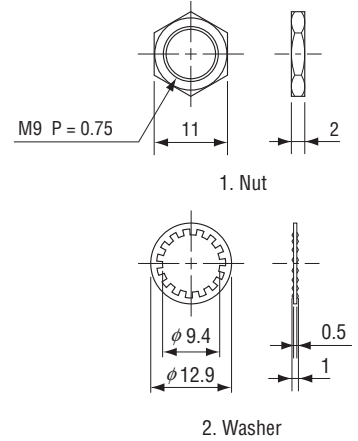

Double shaft and SOCKET

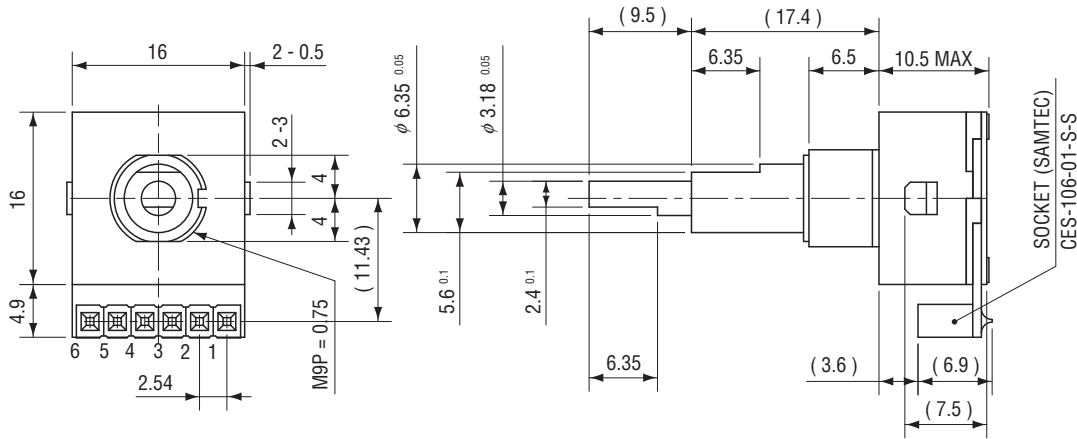

<Option>

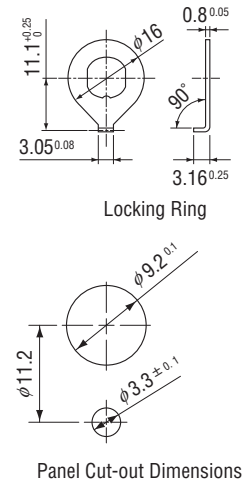

OUTPUT CIRCUITRY AND RECEIVING CIRCUITRY

PIN ASSIGNMENT

Pin No.	Function
1	Power 0 (V)
2	For switch
3	For switch
4	Output "B"
5	Output "A"
6	Power +5 V

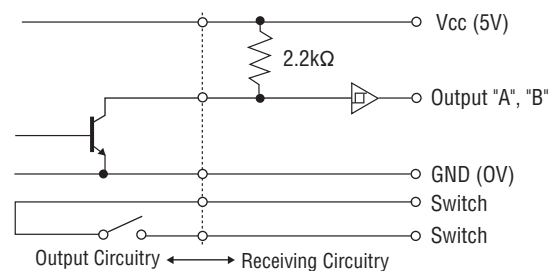

Transistor : RN1707JE equivalent
Schmitt IC : TC7W14FK equivalent

REC16K/REC16L/REC16M

OPTICAL ENCODERS

■ Option (Snap-in Holder)

● Available mounting on PC board with Snap-in Holder as an optional item separately.

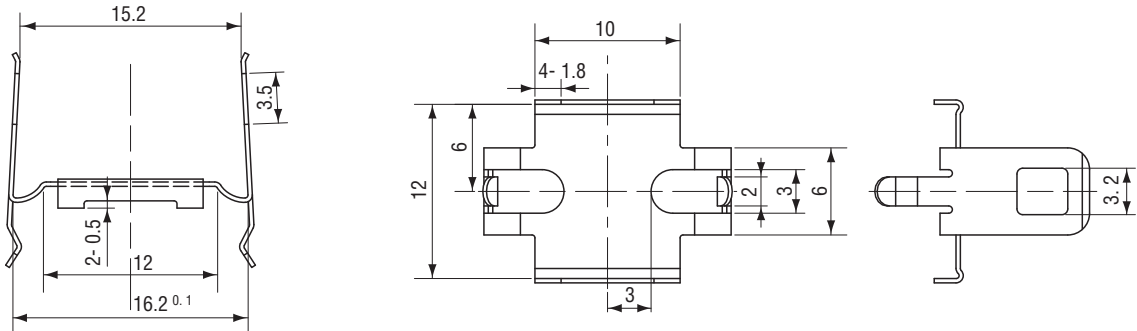

● With Snap-in Holder

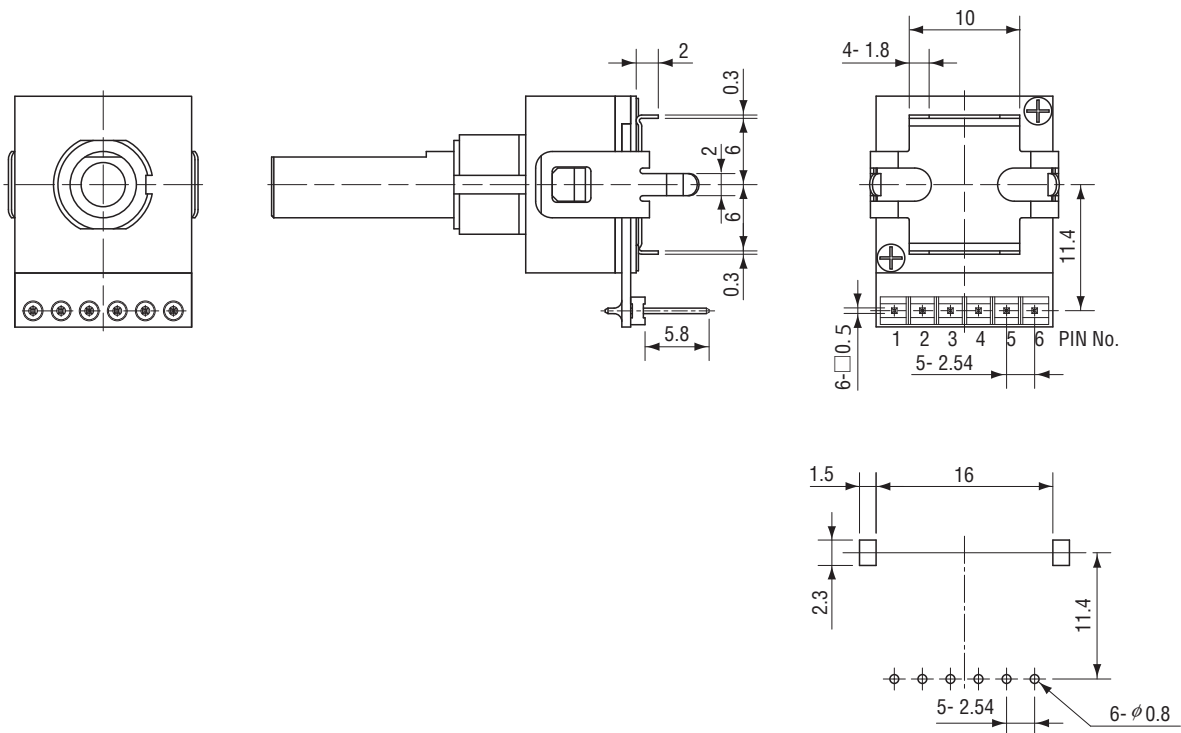

Mounting hole dimensions
 (Tolerance : 0.1)
 (Thickness : t = 1.6)