

DC Pass

Power Splitter/Combiner

ZN6PD-02183+

6 Way-0° 50Ω 2000 to 18000 MHz

The Big Deal

- Ultra-wideband, 2 to 18 GHz
- Low insertion loss, 1.4 dB
- Good power handling, 25W as a splitter
- Low unbalance, 0.4 dB, 6.0°
- High isolation, 22 dB



CASE STYLE: UU2414

Product Overview

Mini-Circuits' ZN6PD-02183+ is a 6way 0° ultra-wideband splitter/combiner supporting a wide range of applications from 2 to 18 GHz. This model is capable of handling up to 25W RF input power as a splitter with low insertion loss across its full frequency range, providing excellent signal power transmission from input to output. It delivers nearly equal output signals with low amplitude unbalance and low phase unbalance, and excellent isolation minimizing interference between channels. The ZN6PD-02183+ comes housed in a rugged, compact aluminum alloy case measuring 4.0 x 6.0 x 0.38" with SMA-Female connectors.

Key Features

Feature	Advantages
Ultra-wideband, 2 to 18 GHz	A single model supports bandwidth requirements for a wide variety of applications including EW, ECM, test instrumentation, ISM and more.
High power handling, 25W as a splitter	The ZN6PD-02183+ is suitable for systems with a wide range of power requirements.
Low insertion loss, 1.4 dB	The combination of 25W power handling and low insertion loss makes this model a suitable candidate for distributing signals while maintaining excellent transmission of signal power.
Low unbalance: <ul style="list-style-type: none">• 0.4 dB amplitude unbalance• 6.0° phase unbalance	Produces nearly equal output signals, ideal for parallel path and multichannel systems.
High isolation, 22 dB	Minimizes interference between ports.
DC Passing, 0.69A (115mA each port)	Supports applications where DC power is needed through the RF line.

Notes

- A. Performance and quality attributes and conditions not expressly stated in this specification document are intended to be excluded and do not form a part of this specification document.
B. Electrical specifications and performance data contained in this specification document are based on Mini-Circuit's applicable established test performance criteria and measurement instructions.
C. The parts covered by this specification document are subject to Mini-Circuits standard limited warranty and terms and conditions (collectively, "Standard Terms"); Purchasers of this part are entitled to the rights and benefits contained therein. For a full statement of the Standard Terms and the exclusive rights and remedies thereunder, please visit Mini-Circuits' website at www.minicircuits.com/MCLStore/terms.jsp



Power Splitter/Combiner

ZN6PD-02183+

6 Way-0° 50Ω 2000 to 18000 MHz

Maximum Ratings

Operating Temperature	-55°C to 100°C
Storage Temperature	-55°C to 100°C
Power Input (as a splitter)	25W max.
Internal Dissipation	0.5W max.
DC Current	0.69A (115mA for each port)

Coaxial Connections

SUM PORT	S
PORT 1,2,3,4,5,6	1,2,3,4,5,6

Outline Drawing

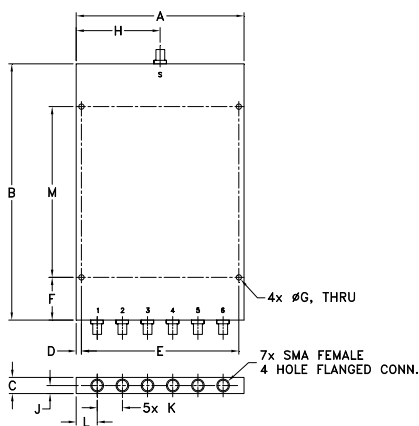

Outline Dimensions (inch/mm)

A	B	C	D	E	F	G
4.00	6.00	.38	.13	3.750	1.00	.125
101.60	152.40	9.65	3.30	95.25	25.40	3.18
H	J	K	L	M	N	wt
2.00	.19	.600	.50	4.000	--	grams
50.80	4.83	15.24	12.70	101.60	--	730

Electrical Schematic

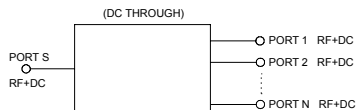

Features

- wideband, 2000 to 18000 MHz
- low insertion loss, 1.4 dB typ.
- low amplitude unbalance, 0.4 dB typ.
- low phase unbalance, 6.0 deg. typ.
- high isolation, 22 dB typ.
- DC Pass from sum port to all output ports

Applications

- EW, ECM
- test equipment
- test lab
- ISM



CASE STYLE: UU2414

Connectors	Model
SMA	ZN6PD-02183-S+

+RoHS Compliant

The +Suffix identifies RoHS Compliance. See our web site for RoHS Compliance methodologies and qualifications

Electrical Specifications at 25°C

Parameter	Frequency (MHz)	Min.	Typ.	Max.	Unit
Frequency Range		2000	—	18000	MHz
Insertion Loss (above theoretical 7.8 dB)	2000 - 18000	—	1.4	2.9	dB
Isolation	2000 - 18000	15	22	—	dB
Phase Unbalance	2000 - 18000	—	6	12	Degree
Amplitude Unbalance	2000 - 18000	—	0.4	1.0	dB
VSWR (Port S)	2000 - 18000	—	1.5	2.0	:1
VSWR Output (Port 1-6)	2000 - 18000	—	1.35	1.5	:1

Typical Performance Data

Frequency (MHz)	Total Loss ¹ (dB)			Amplitude Unbalance (dB)	Isolation (dB)			Phase Unbal. (deg.)	VSWR S	VSWR 1	VSWR 3
	S-1	S-3	S-5		1-2	1-3	1-6				
2000	8.11	8.06	8.09	0.06	26.04	30.39	28.77	0.93	1.16	1.16	1.14
3000	8.20	8.15	8.19	0.05	25.48	32.06	32.36	1.37	1.19	1.08	1.06
4000	8.27	8.23	8.26	0.05	26.86	30.15	38.55	1.84	1.17	1.11	1.16
5000	8.35	8.29	8.31	0.06	21.65	31.68	43.07	2.38	1.11	1.04	1.06
6000	8.50	8.47	8.46	0.06	21.79	30.48	35.66	2.86	1.40	1.09	1.06
7000	8.73	8.63	8.66	0.10	23.76	37.78	38.51	3.26	1.67	1.24	1.15
8000	8.72	8.60	8.65	0.13	21.41	29.53	39.29	3.86	1.45	1.26	1.17
9000	8.82	8.55	8.59	0.27	24.48	32.28	39.95	4.64	1.32	1.30	1.16
10000	8.93	8.74	8.75	0.19	23.22	36.47	35.10	4.52	1.47	1.34	1.12
12000	9.01	8.71	8.71	0.35	27.14	31.14	35.23	4.97	1.16	1.19	1.09
14000	9.14	9.05	8.96	0.23	26.21	28.60	32.67	6.17	1.39	1.22	1.30
15000	9.19	9.18	9.09	0.15	26.84	32.80	34.69	6.40	1.47	1.34	1.41
16000	9.24	9.07	9.06	0.28	25.59	36.50	36.30	7.35	1.24	1.33	1.33
17000	9.30	9.19	9.15	0.26	30.99	39.26	42.72	7.95	1.30	1.36	1.34
18000	9.53	9.40	9.37	0.28	24.64	34.34	41.02	8.77	1.69	1.49	1.47

1. Total Loss = Insertion Loss + 7.8dB splitter loss.

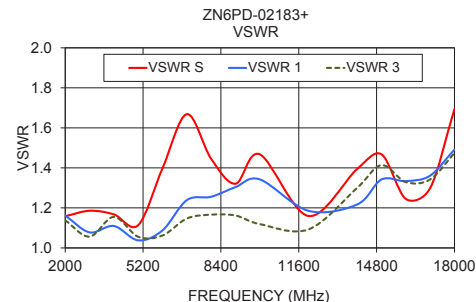
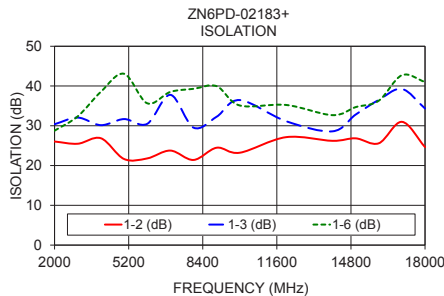
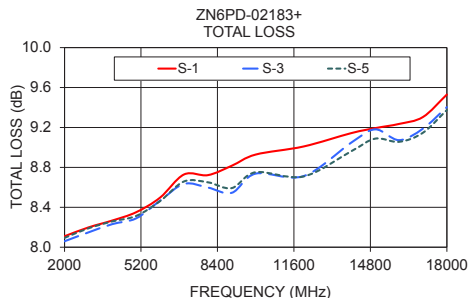

Notes

- Performance and quality attributes and conditions not expressly stated in this specification document are intended to be excluded and do not form a part of this specification document.
- Electrical specifications and performance data contained in this specification document are based on Mini-Circuit's applicable established test performance criteria and measurement instructions.
- The parts covered by this specification document are subject to Mini-Circuit's standard limited warranty and terms and conditions (collectively, "Standard Terms"); Purchasers of this part are entitled to the rights and benefits contained therein. For a full statement of the Standard Terms and the exclusive rights and remedies thereunder, please visit Mini-Circuit's website at www.minicircuits.com/MCLStore/terms.jsp

