

Features

- ▶ Ready-to-use functions
 - On/Off
 - Search Light
 - Dimming
 - Acknowledge
- ▶ Implemented gesture recognition
 - Awareness
 - Tap
 - Time Select
 - Wipe
 - Proximity
- ▶ Detection range approx. 25 cm
- ▶ Direct light control possible
- ▶ PWM-Output (125 Hz, 8 Bit)
- ▶ PCB only application – no mechanics
- ▶ Reference schematics and reference layout available

General Description

Fast and reliable gesture recognition based on the proven robustness of HALIOS[®]. Our technology and long term HMI experience provides an easy to use state-of-the-art interface for your products. Amazing usability included!

The IC is ready to identify the necessary gestures used for basic controls (e. g. dimming). These gestures can be used to directly control the light. Alternatively they can be to be connected to your MCU.

Ordering Information

Product ID	Temp Range	Package
E527.16	-40°C to +85°C	QFN32L5

Applications

- ▶ Innovative motion-controlled light
- ▶ Optical push buttons and controls
- ▶ Wake-up function for saving energy
- ▶ Pre-selection to simplify menu structures

Reference schematics and reference layout for easy implementation are available for free.

Typical Application Circuit

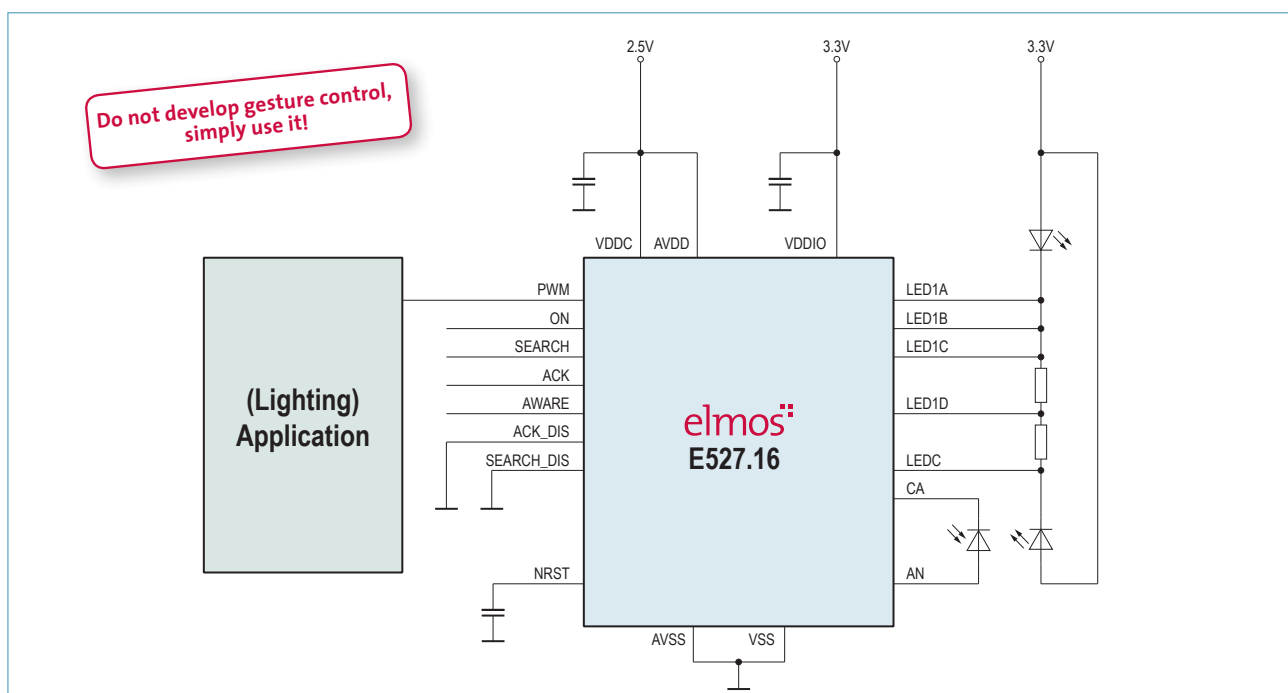

Elmos Semiconductor AG reserves the right to change the detail specifications as may be required to permit improvements in the design of its products.

Functional Diagram

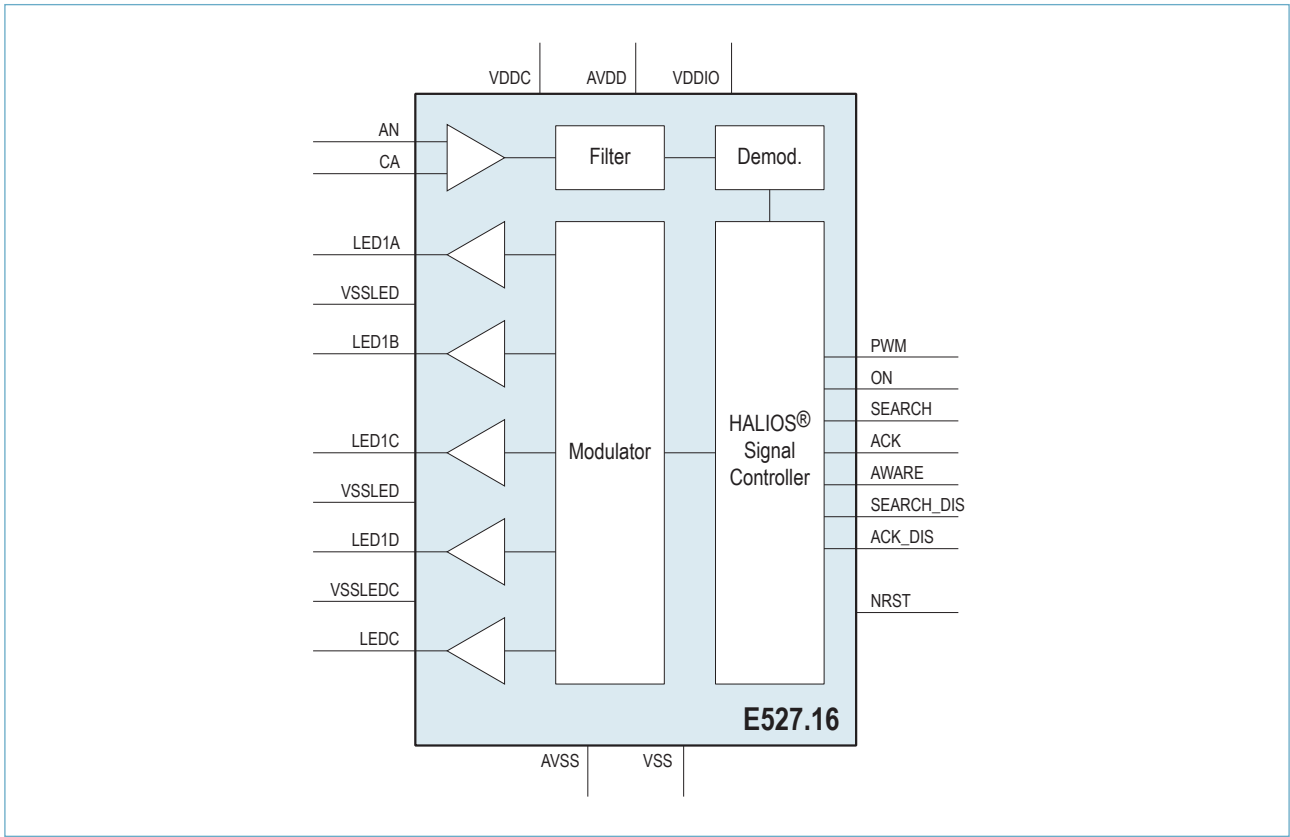

Pin Configuration

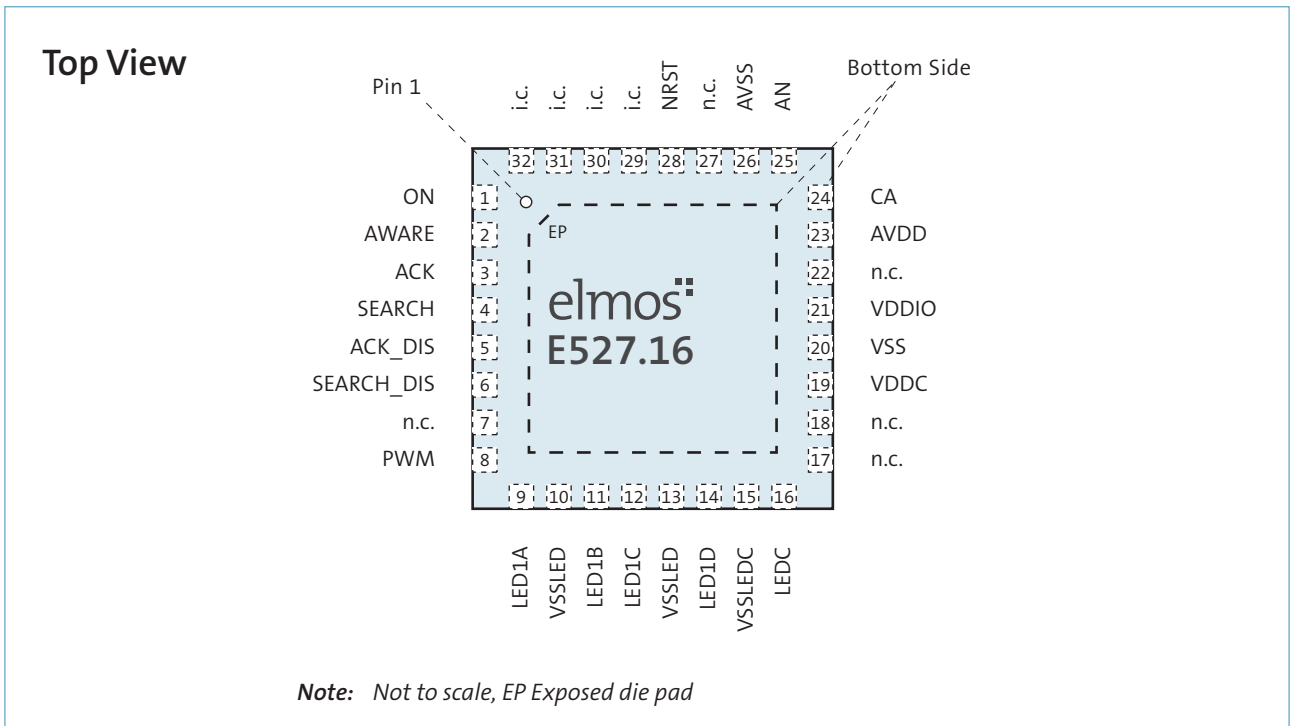

Pin Description

Pin	Name	Type ¹⁾	Description
1	ON	D_O	Digital output, set if the device is in ON state
2	AWARE	D_O	Indicates the status AWARENESS
3	ACK	D_O	Indicates the status ACKNOWLEDGE
4	SEARCH	D_O	Indicates the status SEARCH LIGHT
5	ACK_DIS	D_I	Disables ACKNOWLEDGE function on PWM output
6	SEARCH_DIS	D_I	Disables SEARCH LIGHT function on PWM output
7	n.c.		not connected, leave open
8	PWM	D_O	PWM Output
9	LED1A	A_O	LED Driver output
10	VSSLED	S	Ground LED1A, LED1B
11	LED1B	A_O	LED Driver output
12	LED1C	A_O	LED Driver output
13	VSSLED	S	Ground LED1C, LED1D
14	LED1D	A_O	LED Driver output
15	VSSLEDC	S	Ground LEDC
16	LEDC	A_O	LED Driver output
17	n.c.		not connected
18	n.c.		not connected
19	VDDC	S	Core Supply 2.5V
20	VSS	S	Ground
21	VDDIO	S	IO Supply 3.3V
22	n.c.		not connected
23	AVDD	S	Analog Supply 2.5V
24	CA	A_I	Cathode
25	AN	A_I	Anode
26	AVSS	S	Analog Ground
27	n.c.		not connected
28	NRST	D_I	Reset input, active low, has to be connected via a capacitor to GND
29	i.c.		internal connected, connect to VSS
30	i.c.		internal connected, leave open, do not connect
31	i.c.		internal connected, leave open, do not connect
32	i.c.	S	internal connected, connect to AVSS
-	EP	S	Exposed Die Pad

1) A= Analog, D= Digital, I/O = Input/Output, S= Supply

1 Absolute Maximum Ratings

Stresses beyond these absolute maximum ratings listed below may cause permanent damage to the device. These are stress ratings only; operation of the device at these or any other conditions beyond those listed in the operational sections of this document is not implied. Exposure to absolute maximum rated conditions for extended periods may affect device reliability. All voltages with respect to ground. Currents flowing into terminals are positive, those drawn out of a terminal are negative.

Description	Condition	Symbol	Min	Max	Unit
Supply voltage: digital core, analog part	Referenced to V_{SS}/A_{VSS}	V_{DDC}/A_{VDD}	-0.3	2.8	V
IO supply voltage/digital pins	Referenced to V_{SS}	V_{DDIO}	-0.3	3.7	V
Input voltage analog pins	Referenced to A_{VSS}	V_{INA}	-0.3	$A_{VDD} + 0.3$	V
Input voltage digital pins ACK_DIS, SEARCH_DIS, NRST	Referenced to V_{SS}	V_{IND}	-0.3	$V_{DDIO} + 0.3$	V
Ground offset	V_{SS} to A_{VSS} to V_{SSLED}	ground offset	-0.3	+0.3	V
Junction temperature		T_J	-40	+125	°C
Storage temperature		T_{STG}	-50	+150	°C

2 Recommended Operating Conditions

The parameters are guaranteed within the range of recommended operating conditions unless otherwise specified. All voltages are referred to ground (0V) and currents are flowing into the circuit have positive values. The first electrical potential connected to the IC must be GND. (If not specified specify timing sequence of electrical contacts.)

Description	Condition	Symbol	Min	Typ	Max	Unit
Supply voltage: analog part, digital core	Referenced to V_{SS}/A_{VSS}	V_{DDC}/A_{VDD}	2.25	2.5	2.75	V
IO supply voltage/digital pins	Referenced to V_{SS}	V_{DDIO}	3.0	3.3	3.6	V
Filter capacitor analog part	Connected to A_{VDD}	C_{AVDD}		10		μF
Filter capacitor digital part	Connected to V_{DDC}	C_{VDDC}		100		nF
Ambient operating temperature range		T_{OPT}	-40	+25	+85	°C

All voltages are referred to V_{SS} , and currents are positive when flowing into the node unless otherwise specified.

3 ESD Protection

Description	Condition	Symbol	Min	Max	Unit
ESD HBM protection	HBM ¹⁾		±2	-	kV
ESD CDM at edge pins	CDM ²⁾	$V_{PINS\ EDGE}$	±0.75	-	kV
ESD CDM at all other pins	CDM ²⁾	$V_{PINS\ OTHER}$	±0.5	-	kV

Note: Test point defined as tested pin to supply.

1) According to AEC-Q 100-002, Human Body Model, 1.5kΩ resistance, 100pF capacitance.

2) According to AEC-Q 100-011, Charged Device Model, pulse rise time (10% to 90%) <400ps, 1Ω resistance.

4 Electrical Characteristics

($V_{DDC}/A_{VDD} = +2.25V$ to $+2.75V$, $T_{OP} = -40^{\circ}C$ to $+85^{\circ}C$, unless otherwise noted. Typical values are at $V_{DDC}/A_{VDD} = +2.5V$ and $T_{OP} = +25^{\circ}C$. Positive currents flow into the device pins.)

Description	Condition	Symbol	Min	Typ	Max	Unit
Power Supply						
Current consumption in application mode	On Mode ¹⁾	I_{ON}		4		mA
PWM Output						
Output Voltage Low	$V_{DDIO} = 3.3V$	IO_{VOL}			0.5	V
Output Voltage High	$V_{DDIO} = 3.3V$	IO_{VOH}	2.4			V
Low level output current	$V_{OVOL} = 0.4V$	IO_{IOL}	4		17	mA
High level output current	$V_{OVOH} = 2.4V$	IO_{IOH}	-25.6		-6	mA
PWM frequency		f_{PWM}		125		Hz
PWM resolution		PWM_{res}		8		Bit
Digital IO						
Threshold point of the inputs AWARE_DIS, ACK_DIS ¹⁾		IO_{TH}	1.2	1.32	1.46	V
Pull down resistor at digital in and outputs	$V_{IN} > 0.75 \cdot V_{DDIO}$	R_{IOPD}	45		155	k Ω
Output Voltage Low	OL=4 mA; $V_{DDIO} = 3.3V$	IO_{VOL}			0.5	V
Output Voltage High	OH=-4 mA; $V_{DDIO} = 3.3V$	IO_{VOH}	2.4			V
Low level output current ¹⁾	VOL=0.4V	IO_{IOL}	4		17	mA
High level output current ¹⁾	VOH=2.4V	IO_{IOH}	-25.6		-6	mA
LED Driver 1A, 1B, 1C, 1D						
Max. output current at each LED output LED1A, LED1B, LED1C, LED1D		I_{LED}		20		mA
PWM frequency of the LED outputs		f_{PWM}		166		kHz
PWM duty cycle of the LED outputs		PWM_{duty}		50/50		
LEDC Driver						
Output current of LEDC		I_{LEDC}		9	13	mA
PWM frequency of the compensation LEDC		f_{PWM}		166		kHz
PWM duty cycle of LEDC		PWM_{duty}		50/50		
Receiver						
Voltage at amplifier input CA		V_{CA}		1.9		V
Voltage at amplifier input AN		V_{AN}		1.3		V
Capacitance of photo diode at input CA	¹⁾	C_{DIODE}			70	pF

1) Will not be tested in production.

5 Functional Description

Gesture Definition

The implemented control logic recognizes the following gestures:

- **Awareness** -> An object (e.g. a hand) enters the detection zone.
- **Tap** -> A quick movement in the direction of the sensor back and forth similar to pushing a virtual button in the air.
- **Time Select** -> Hover in the detection range for a certain time.
- **Wipe** -> A movement horizontal to the sensor surface with a certain speed.
- **Proximity** -> A movement with continues speed in direction to or from the sensor.

System States

The following states are possible:

- **Off** -> After power on the devices enters the OFF-state.
- **Search Light** -> The lamp shines with a brightness of minimum PWM duty cycle.
- **On** -> The lamp shines with the adjusted brightness.
- **Proximity** -> The lamp shines with a brightness in between 0% and 100%. Step size is 0.4%.
- **Acknowledge** -> Short indication of a status change. If ACK_DIS is not set to high the indication is shown by a variation of the brightness. If the brightness is < 50% it will increase and if it is > 50% it will decrease.

Control Concept

The control concept is based on three main procedures:

Search Light

If the lamp is in OFF state and an object enters the detection range the lamp shines with a brightness of minimum PWM duty cycle. As soon as the object leaves the detection zone or it stays there > 3s the lamp is turned off. In the case the lamp is in ON state "Awareness" is notified but there is no further reaction from the lamp.

This indicates to the customer "I am ready" and helps to get a feeling of the detection zone. Also it provides the possibility to have a glimpse to the surrounding area. By setting the input SEARCH_DIS to VDDIO the change of the PWM output is disabled.

Switching On and Off

The "Tap" gesture is acting like a toggle on/off switch. If the lamp is "On" it will be switched off and vice versa. Between two taps the detection zone has to be left. The same function can be realized by a wipe.

Proximity and Acknowledge

Once the lamp is switch on it can be adjusted to any desired brightness. With the "time select" gesture the status "dimming" will be entered and be confirmed be an "Acknowledge".

Now the brightness of the lamp follows the hand. The closer the hand the brighter the lamp shines and the farer away the darker it will be.

Leaving the detection zone for a certain time during dimming will stop the procedure and the previous brightness before the "Time Select" will be set.

The dimming procedure is ended by a second "Time Select" and will be confirmed again by an "Acknowledge". That brightness will be kept until the lamp is switched off or a dimming procedure is started again.

Before starting the next procedure the detection zone has to be left.

The confirmation via the "Acknowledge" at the PWM output can also be disabled by setting the ACK_DIS to VDDIO but is still be indicate at the pin ACK.

Overall this represents a state of the art gesture controlled input device. Field-tested, reliable, suitable for many products and optimized to be implemented in lamps, the E527.16 opens the door to a new intuitive user interface - all of this under the same conditions as a standard switch.

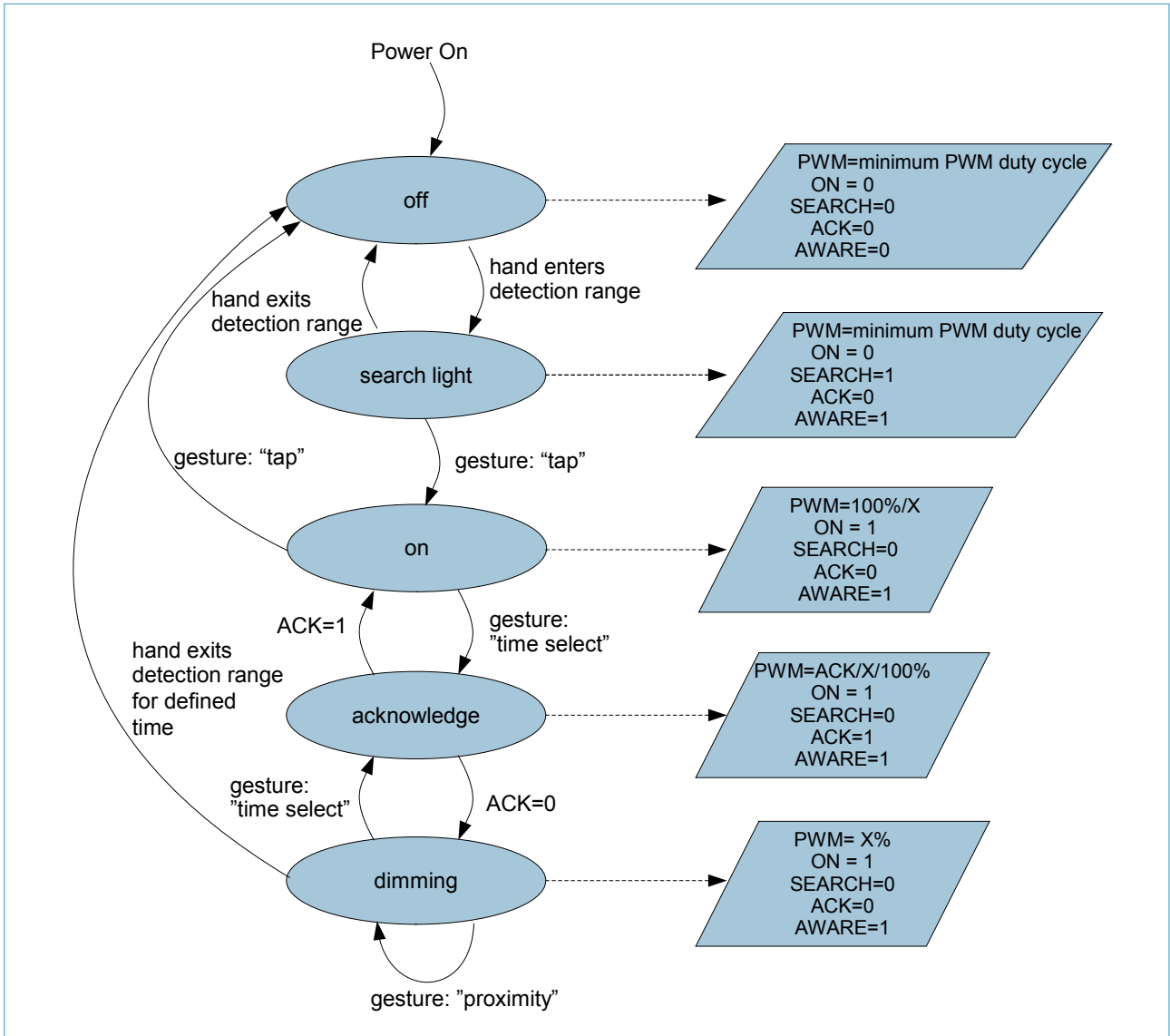
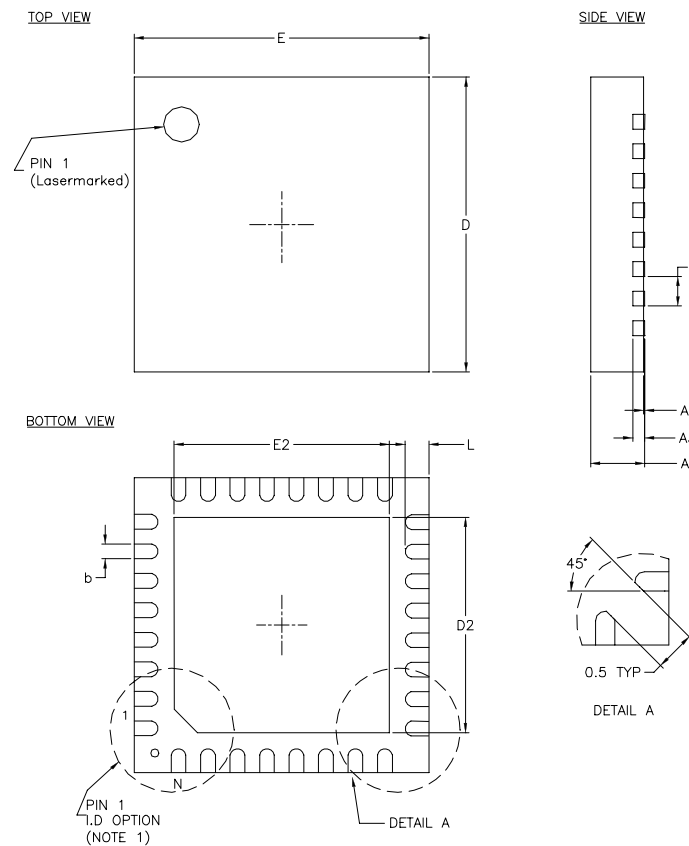

Figure 1. Flow chart

6 Package Information

The E527.16 is available in a Pb free, RoHs compliant QFN32L5 plastic package according to JEDEC MO-220 K, variant VHHD-4. The package is classified to Moisture Sensitivity Level 3 (MSL 3) according to JEDEC J-STD-020 with a soldering peak temperature of (260+5)°C.



Description	Symbol	mm			inch		
		min	typ	max	min	typ	max
Package height	A	0.80	0.90	1.00	0.031	0.035	0.039
Stand off	A1	0.00	0.02	0.05	0.000	0.00079	0.002
Thickness of terminal leads, including lead finish	A3	--	0.20 REF	--	--	0.0079 REF	--
Width of terminal leads	b	0.18	0.25	0.30	0.007	0.010	0.012
Package length / width	D / E	--	5.00 BSC	--	--	0.197 BSC	--
Length / width of exposed pad	D2 / E2	3.50	3.65	3.80	0.138	0.144	0.150
Lead pitch	e	--	0.5 BSC	--	--	0.02 BSC	--
Length of terminal for soldering to substrate	L	0.35	0.40	0.45	0.014	0.016	0.018
Number of terminal positions	N		32			32	

Note: the mm values are valid, the inch values contains rounding errors

7 Marking

7.1 Top Side

- ▶ Elmos Logo
- ▶ 52716
- ▶ XXXSL
- ▶ YWWR@

Signature	Explanation
52716	Elmos project number
A	Elmos project revision code
XXX	Production lot number
S	Assembler code
L	Production line code
YWW	Year and week of assembly
R	Mask revision code
@	Elmos internal code

WARNING – Life Support Applications Policy

Elmos Semiconductor AG is continually working to improve the quality and reliability of its products. Nevertheless, semiconductor devices in general can malfunction or fail due to their inherent electrical sensitivity and vulnerability to physical stress. It is the responsibility of the buyer, when utilizing Elmos Semiconductor AG products, to observe standards of safety, and to avoid situations in which malfunction or failure of an Elmos Semiconductor AG Product could cause loss of human life, body injury or damage to property. In the development of your design, please ensure that Elmos Semiconductor AG products are used within specified operating ranges as set forth in the most recent product specifications.

General Disclaimer

Information furnished by Elmos Semiconductor AG is believed to be accurate and reliable. However, no responsibility is assumed by Elmos Semiconductor AG for its use, nor for any infringements of patents or other rights of third parties, which may result from its use. No license is granted by implication or otherwise under any patent or patent rights of Elmos Semiconductor AG. Elmos Semiconductor AG reserves the right to make changes to this document or the products contained therein without prior notice, to improve performance, reliability, or manufacturability.

Application Disclaimer

Circuit diagrams may contain components not manufactured by Elmos Semiconductor AG, which are included as means of illustrating typical applications. Consequently, complete information sufficient for construction purposes is not necessarily given. The information in the application examples has been carefully checked and is believed to be entirely reliable. However, no responsibility is assumed for inaccuracies. Furthermore, such information does not convey to the purchaser of the semiconductor devices described any license under the patent rights of Elmos Semiconductor AG or others.

Contact Information

Headquarters

Elmos Semiconductor AG
Heinrich-Hertz-Str. 1 • D-44227 Dortmund (Germany) ☎: +492317549100 ✉: sales-germany@elmos.com 🌐: www.elmos.com

Regional Sales and Application Support Office Munich

Elmos Semiconductor AG
Am Geflügelhof 12 • D-85716 Unterschleißheim/Eching (Germany) ☎: +49893183700 ✉: sales-germany@elmos.com

Sales and Application Support Office North America

Elmos NA. Inc.
32255 Northwestern Highway • Suite 220 Farmington Hills
MI 48334 (USA) ☎: +12488653200 ✉: sales-usa@elmos.com

Sales and Application Support Office Korea and Japan

B-1007, U-Space 2, #670 Daewangpangyo-ro,
Sampyoung-dong, Bunddang-gu, Sungnam-si
Kyonggi-do 463-400 Korea ☎: +82317141131 ✉: sales-korea@elmos.com

Sales and Application Support Office China

Elmos Semiconductor Technology (Shanghai) Co., Ltd.
Unit London, 1BF GC Tower • No. 1088 Yuan Shen Road,
Pudong New District • Shanghai, PR China, 200122 ☎: +862151785178 ✉: sales-china@elmos.com

Sales and Application Support Office Singapore

Elmos Semiconductor Singapore Pte Ltd.
3A International Business Park
#09-13 ICON@IBP • 609935 Singapore ☎: +65 6908 1261 ✉: sales-singapore@elmos.com

© Elmos Semiconductor AG, 2013. Reproduction, in part or whole, without the prior written consent of Elmos Semiconductor AG, is prohibited.

Elmos Semiconductor AG reserves the right to change the detail specifications as may be required to permit improvements in the design of its products.