

SEK37-HFB0-K02

SEK/SEL37

MOTOR FEEDBACK SYSTEMS ROTARY HIPERFACE®

SICK
Sensor Intelligence.



Illustration may differ

Ordering information

Type	Part no.
SEK37-HFB0-K02	1037378

Other models and accessories → www.sick.com/SEK_SEL37

Detailed technical data

Performance

Number of sine/cosine periods per revolution	16
Number of the absolute ascertainable revolutions	1
Maximum number of steps per revolution	512 via RS485
Total number of steps	512
Measuring step	20 Winkelsekunden For interpolation of the sine/cosine signals with, e. g., 12 bits
Integral non-linearity typ.	± 288 Winkelsekunden, Error limits for evaluating sine/cosine period, Typical values for nominal position ± 0.1 mm and + 20 °C
Differential non-linearity	± 144 Winkelsekunden, Non-linearity within a sine/cosine period, Typical values for nominal position ± 0.1 mm and + 20 °C
Operating speed	6,000 min ⁻¹ , up to which the absolute position can be reliably produced

Interfaces

Type of code for the absolute value	Binary
Code sequence	Increasing, when turning the shaft For clockwise rotation, looking in direction "A" (see dimensional drawing), for clockwise shaft rotation, looking in direction "A" (see dimensional drawing)
Communication interface	HIPERFACE®
Available memory area	1,792 Byte

Electrical data

Supply voltage range	7 V DC ... 12 V DC
Recommended supply voltage	8 V DC
Operating power consumption (no load)	< 50 mA ¹⁾

¹⁾ Without load.

Mechanical data

Shaft version	Tapered shaft
Dimensions	See dimensional drawing
Weight	0.05 kg
Moment of inertia of the rotor	1 gcm ²
Operating speed	12,000 min ⁻¹ , 12,000 U/min
Angular acceleration	≤ 500,000 rad/s ²

Permissible radial shaft movement	± 0.15 mm
Permissible axial shaft movement	± 0.3 mm
Connection type	Male connector M12, 8-pin, radial

Ambient data

Operating temperature range	-40 °C ... +115 °C
Storage temperature range	-50 °C ... +125 °C, without package
Relative humidity/condensation	90 %, Condensation not permitted
Resistance to shocks	100 g, 10 ms, 10 ms (according to EN 60068-2-27)
Frequency range of resistance to vibrations	50 g, 10 Hz ... 2,000 Hz (according to EN 60068-2-6)
EMC	According to EN 61000-6-2 and EN 61000-6-3 ¹⁾
Enclosure rating	IP20, built-on version, with mating connector inserted and closed cover (according to IEC 60529)

¹⁾ The EMC according to the standards quoted is achieved when the motor feedback system is mounted in an electrically conductive housing, which is connected to the central earthing point of the motor controller via a cable screen. If other screening concepts are used, users must perform their own tests.

Classifications

ECI@ss 5.0	27270590
ECI@ss 5.1.4	27270590
ECI@ss 6.0	27270590
ECI@ss 6.2	27270590
ECI@ss 7.0	27270590
ECI@ss 8.0	27270590
ECI@ss 8.1	27270590
ECI@ss 9.0	27270590
ETIM 5.0	EC001486
ETIM 6.0	EC001486
UNSPSC 16.0901	41112113

Dimensional drawing (Dimensions in mm (inch))

General tolerances according to DIN ISO 2768-mk

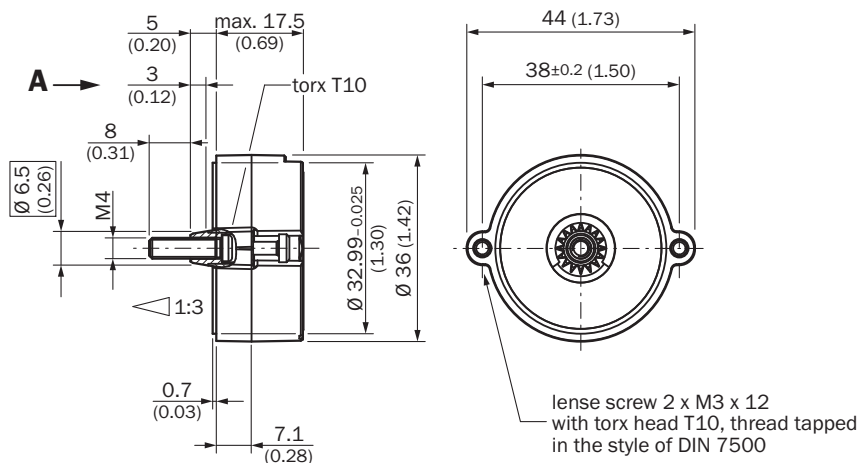

Radial

Proposed fitting

General tolerances according to DIN ISO 2768-mk

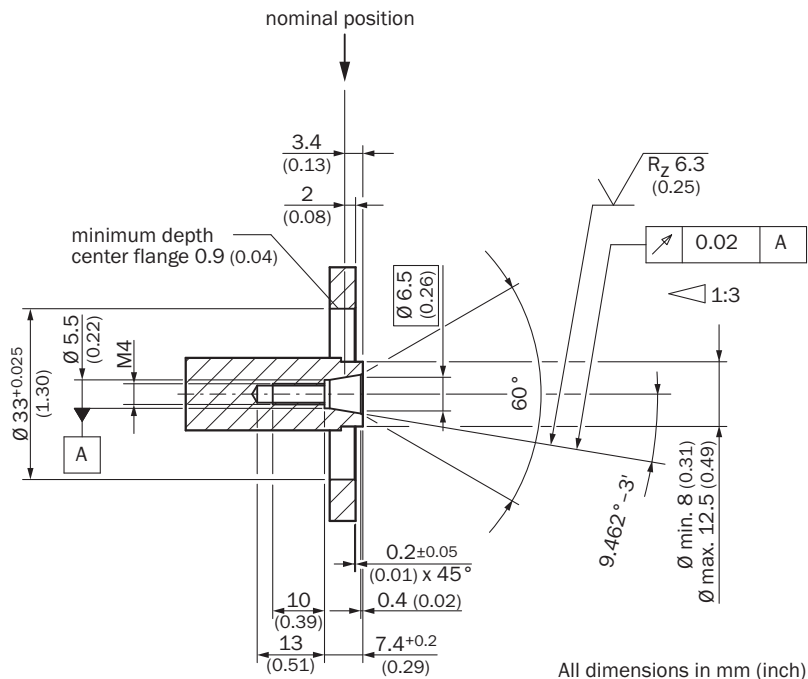

Radial

PIN assignment

View of the plug-in face

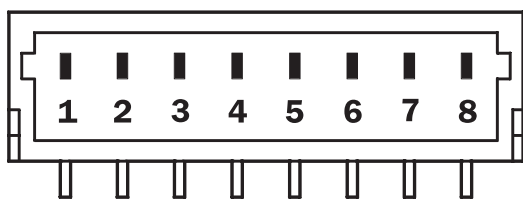

PIN	Signal	Colour of wires (cable outlet)	Explanation
1	U _S	Red	Supply voltage
2	+ SIN	White	Process data channel
3	REFSIN	Brown	Process data channel
4	+ COS	Pink	Process data channel
5	REFCOS	Black	Process data channel
6	GND	Blue	Ground connection
7	Data +	Gray or yellow	Parameter channel RS 485
8	Data -	Green or purple	Parameter channel RS 485

The GND (0 V) connection of the supply voltage has no connection to the housing

Diagram

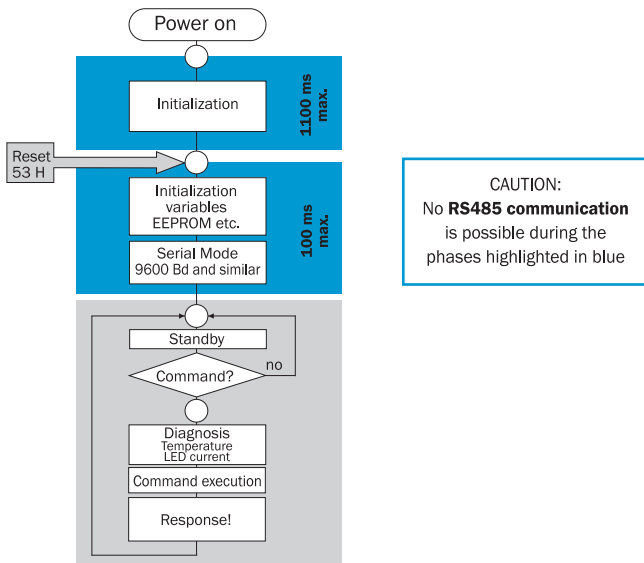



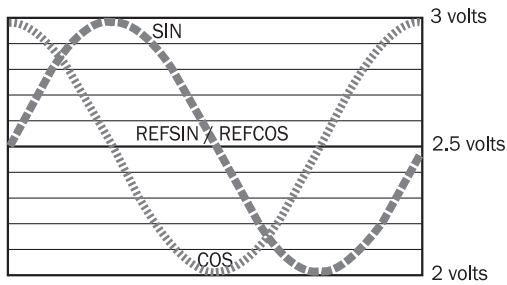

Signal diagram for clockwise shaft rotation, looking in direction "A" (see dimensional drawing) 1 period = 360° : 16



Recommended accessories

Other models and accessories → www.sick.com/SEK_SEL37

	Brief description	Type	Part no.
Plug connectors and cables			
	Head A: cable Head B: cable Cable: HIPERFACE®, HIPERFACE®, drag chain use, PUR, halogen-free, shielded	LTG-2708-MW	6028361
	Head A: female connector, JST, 8-pin, straight Head B: cable Cable: HIPERFACE®, unshielded, 0.2 m	DOL-0J08-G0M2XB6	2031086
	Head A: female connector, M23, 12-pin, straight Head B: male connector, M23, 17-pin, straight Cable: HIPERFACE®, unshielded, 1 m	DSL-2317-G01MJB2	2071328
	Head A: female connector, JST, 8-pin, straight Head B: male connector, M23, 17-pin, straight Cable: HIPERFACE®, unshielded, 1 m	DSL-2317-G01MJB6	2071327

	Brief description	Type	Part no.
	Head A: female connector, M12, 8-pin, straight Head B: male connector, M23, 17-pin, straight Cable: HIPERFACE®, unshielded, 1 m	DSL-2317-G01MJC1	2071329
	Head A: female connector, terminal box, 8-pin, straight Head B: male connector, M23, 17-pin, straight Cable: HIPERFACE®, unshielded, 1 m	DSL-2317-G01MJC6	2071330

SICK AT A GLANCE

SICK is one of the leading manufacturers of intelligent sensors and sensor solutions for industrial applications. A unique range of products and services creates the perfect basis for controlling processes securely and efficiently, protecting individuals from accidents and preventing damage to the environment.

We have extensive experience in a wide range of industries and understand their processes and requirements. With intelligent sensors, we can deliver exactly what our customers need. In application centers in Europe, Asia and North America, system solutions are tested and optimized in accordance with customer specifications. All this makes us a reliable supplier and development partner.

Comprehensive services complete our offering: SICK LifeTime Services provide support throughout the machine life cycle and ensure safety and productivity.

For us, that is “Sensor Intelligence.”

WORLDWIDE PRESENCE:

Contacts and other locations –www.sick.com