

DRAN I20* SERIES



FOR DC BACKUP SYSTEM

AC - DC DIN RAIL MOUNTABLE POWER SUPPLY
INDUSTRIAL CONTROL EQUIPMENT

FEATURES

- PFC FUNCTION AVAILABLE
- INPUT VOLTAGE 115/230VAC AUTO SELECT
- SELV COMPONENTS DESIGN
- 3 YEARS WARRANTY



SELECTION CHART

DRAN I20 - 24 A *

Wattage $\underbrace{\hspace{1.5cm}}$ | $\underbrace{\hspace{1.5cm}}$ | $\underbrace{\hspace{1.5cm}}$ | DC Backup System
 12 : 13.6V OUT / 24 : 27.2V OUT / 48 : 54.5V OUT | SCREW TERMINAL

MODEL LIST

MODEL NO.	INPUT VOLTAGE	OUTPUT WATTAGE	OUTPUT VOLTAGE	OUTPUT CURRENT	EFF. (min.)	EFF. (typ.)
Single Output Models						
DRAN I20-12A*	115 / 230 VAC	120 WATTS	+ 13.6 VDC	8.8 A	82%	84%
DRAN I20-24A*	115 / 230 VAC	120 WATTS	+ 27.2 VDC	4.4 A	84%	86%
DRAN I20-48A*	115 / 230 VAC	120 WATTS	+ 54.5 VDC	2.2 A	85%	87%

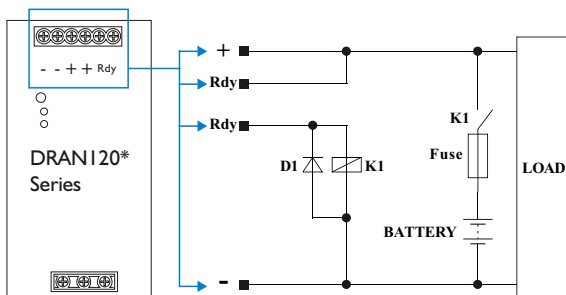

DRAN I20* Series For DC Backup System Application

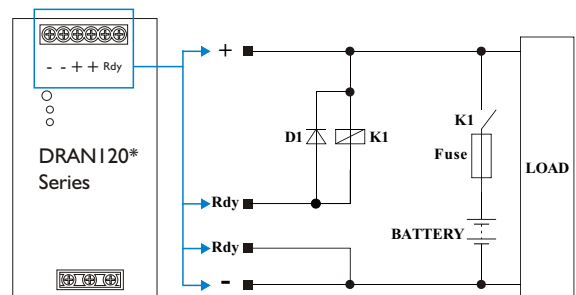

DRAN I20* Series For DC Backup System Application

Note :

1. The suffix "1" is part of the model number, which specifies the product is designed and pre-trim for low-cost DC backup power system with external Lead-Acid battery, Relay and Fuse.
2. The manufacturer is liable for the external components nor the damage to the power supply causing by external components.
3. The total consumption current including loading and battery charging current should not exceed the maximum rated current of power supply.
4. The operation concept of DC backup power system :
 - A. When AC power alive : The "Rdy" is close circuit to activate the external Relay . The power supply feeds current into the external loads and charges through Relay to the external battery as well.
 - B. When AC power interrupted : The "Rdy" is remain close circuit to maintain the external Relay remain active, the external battery supply current to the external loads.
 - C. When Battery power low : The "Rdy" become open circuit and the external Relay become inactive to disconnect the battery from external loads.

SPECIFICATION

All Specifications Typical At Nominal Line, Full Load, 25°C Unless Otherwise Noticed

GENERAL						
Characteristics	Conditions		min.	typ.	max.	unit
Switching frequency	Vi nom, lo nom			55		KHz
Isolation voltage	Input-Output		3,000 / 4,242			VAC / VDC
	Input-FG		1,500 / 2,121			VAC / VDC
	Output-FG		500 / 710			VAC / VDC
	Input-Output, @ 500VDC		100			MΩ
Ambient temperature	Operating at Vi nom		-35		+ 71	°C
Derating (see derating curve)	Vi nom, from +61°C to +71°C				2.5	% / °C
Storage temperature	Non operational		-40		+ 85	°C
			20		95	% RH
Temperature coefficient	Vi nom, lo min				± 0.03	% / °C
MTBF	Bellcore Issue 6 @40°C, GB	12V		481,000		Hours
		24V		517,000		Hours
		48V		576,000		Hours
Altitude during operation	EN 60950-1				5,000	m
Dimension	Screw terminal type		L124.5 x W64 x D123.6			mm
Cooling	Free air convection					
Installation position	Vertical (other direction may derating using)					
Pollution degree			2			
INPUT SPECIFICATIONS						
Characteristics	Conditions		min.	typ.	max.	unit
Rated input voltage	lo nom		115 / 230 (auto select)			VAC
Absolute input max. range	Ta min ... Ta max, lo nom	AC in	90		132	VAC
		AC in	180		264	VAC
		DC in	210		375	VDC
Input current	Vi : 115 / 230 VAC, lo nom			2.2 / 0.83		A
Rated input current	Vi : 90 / 180 VAC, lo nom				2.8 / 1.4	A
Line frequency	Vi nom, lo nom		47		63	Hz
Inrush current	Vi : 115 / 230 VAC , lo nom				24 / 48	A
Power dissipation	Vi : 230 VAC, lo nom	12V		24		W
		24V		20		W
		48V		19		W
Leakage current	Input-Output				0.25	mA
	Input-FG				3.5	mA
Power factor (Passive)	Vi : 230VAC, lo nom			0.7		
OUTPUT SPECIFICATIONS						
Characteristics	Conditions		min.	typ.	max.	unit
Output voltage accuracy (Adjusted before shipment)	Vi nom, lo max				± 1	%
Minimum load	Vi nom		0			%
Line regulation	lo nom, Vi min ...Vi max				± 0.5	%
Load regulation	Vi nom, lo min ...lo nom				± 1	%
Voltage trim range	Vi nom, 0.8 lo nom	12V	11.4		14.5	VDC
		24V	22.5		28.5	VDC
		48V	45		55	VDC
Hold up time	Vi : 115 / 230 VAC , lo nom		25 / 30			ms
Turn on time	Vi nom, lo nom				1,000	ms
	Vi nom, lo nom → 12V model : with 7000 μF CAP 24V, 48V models : with 3500 μF CAP				1,500	ms
Rise time	Vi nom, lo nom				150	ms
	Vi nom, lo nom → 12V model : with 7000 μF CAP 24V, 48V models : with 3500 μF CAP				500	ms
Fall time	Vi nom, lo nom				150	ms
Transient recovery time	Vi nom, I~0.5 lo nom				2	ms

SPECIFICATION

All Specifications Typical At Nominal Line, Full Load, 25°C Unless Otherwise Noticed

OUTPUT SPECIFICATIONS

Characteristics	Conditions	min.	typ.	max.	unit
Ripple & noise	Vi nom, lo nom, BW = 20MHz			50	mV
Power back immunity	Vi nom, lo nom	12V	18		VDC
		24V	35		VDC
		48V	63		VDC
Capacitor load	Vi nom, lo nom	12V		7,000	μF
		24V, 48V		3,500	μF
DC ON indicator threshold at start up (Green LED)	Vi nom, lo nom	12V	10.4	11.4	VDC
		24V	21.2	22.2	VDC
		48V	42.8	43.8	VDC
DC LOW indicator threshold after start up (Red LED)	Vi nom, lo nom	12V	10.3	11.3	VDC
		24V	21.1	22.1	VDC
		48V	42.7	43.7	VDC

CONTROL AND PROTECTION

Characteristics	Conditions	min.	typ.	max.	unit
Input fuse		T3.15A / 250 VAC internal			
Internal surge voltage protection	IEC 61000-4-5	Varistor			
Rated over load protection	Vi nom	105		125	%
Power Rdy	Rdy Close indicator threshold at start up	12V	10.4	11.4	VDC
		24V	21.2	22.2	VDC
		48V	42.8	43.8	VDC
Power Rdy	Rdy Open indicator threshold after start up	12V	10.3	11.3	VDC
		24V	21.1	22.1	VDC
		48V	42.7	43.7	VDC
	Electrical isolation	500			VDC
	Contact rating at 60VDC			0.3	A
Over voltage protection	Vi nom, 0.8 lo nom (Auto Recovery)	12V	15	16.8	V
		24V	30	33	V
		48V	60	66	V
Output short circuit		Fold forward			
Degree of protection		IP20			

APPROVALS AND STANDARDS

UL / cUL	UL 508 Listed UL 60950-1 Recognized ISA 12.12.01(Class I, Division 2, Groups A, B, C and D)
TUV	EN 60950-1
CE	EN 61000-6-3, EN 55022 Class B, EN 61000-3-2 Class D, EN 61000-3-3 EN 61000-6-2, EN 55024, EN 61000-4-2 Level 4, EN 61000-4-3 Level 3 EN 61000-4-4 Level 4, EN 61000-4-5 L-N Level 3, L / N-FG Level 4 EN 61000-4-6 Level 3, EN 61000-4-8 Level 4, EN 61000-4-11 ENV 50204 Level 2, EN 61204-3
CCC	GB4943.1, GB9254, GB17625.1
Vibration resistance	meet IEC 60068-2-6 (Mounting on rail : 10-500 Hz, 2G, along X, Y, Z each Axis, 60 min for each Axis)
Shock resistance	meet IEC 60068-2-27 (15G, 11ms, 3 Axis, 6 Faces, 3 times for each Face)

PHYSICAL CHARACTERISTICS

Case size	124.5 x 64 x 123.6 mm (4.9x 2.52 x 4.87 inches)
Case material	Metal
Weight	920 g
Packing	1.02 kg ; 20pcs / 21.5 kg / 2.01 CUFT

MECHANISM & PIN CONFIGURATION

mm [inch]

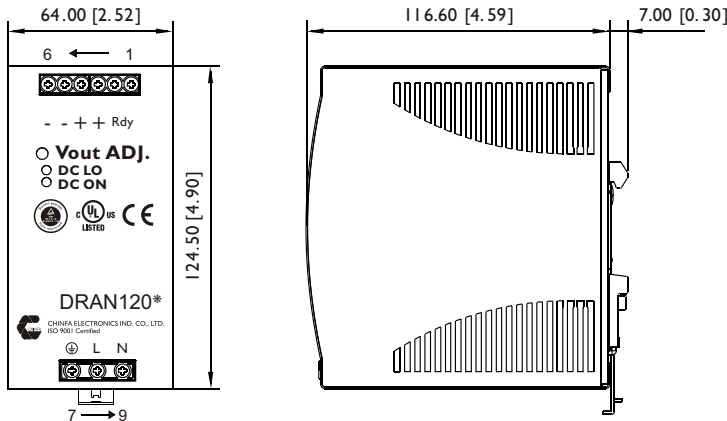

CONSTRUCTION

Easy snap-on mounting onto the DIN-Rail (TS35/7.5 or TS35/15), unit sits safely and firmly on the rail.

INSTALLATION

Ventilation / Cooling
 Normal convection
 All sides 25mm free space
 For cooling recommended

Connector size range
 Screw terminal:
 AWG24-10(0.2~4mm²) flexible / solid cable,
 -Input connector can withstand torque at maximum 9 pound-inches.
 -Output connector can withstand torque at maximum 5.5 pound-inches.
 8 m/m stripping at cable end recommends
 Use copper conductors only, 60 / 75°C

GENERAL TOLERANCE	
0.00[0.00] - 30.00[1.18]	±0.30[0.01]
30.00[1.18] - 120.00[4.72]	±0.50[0.02]
120.00[4.72] - 400.00[15.75]	±0.80[0.03]

PIN ASSIGNMENT

PIN NO.	Designation	Description
1, 2	RDY	A normal open relay contact for DC ON level control
3, 4	V +	Positive output terminal
5, 6	V -	Negative output terminal
7	⊕	Ground this terminal to minimize high-frequency emissions
8	L	Input terminals (phase conductor, no polarity at DC input)
9	N	Input terminals (neutral conductor, no polarity at DC input)
	DC ON	Operation indicator LED
	DC LO	DC LOW voltage indicator LED
	Vout ADJ.	Trimmer-potentiometer for Vout adjustment

CIRCUIT SCHEMATIC

• Block diagram for DRAN120* series

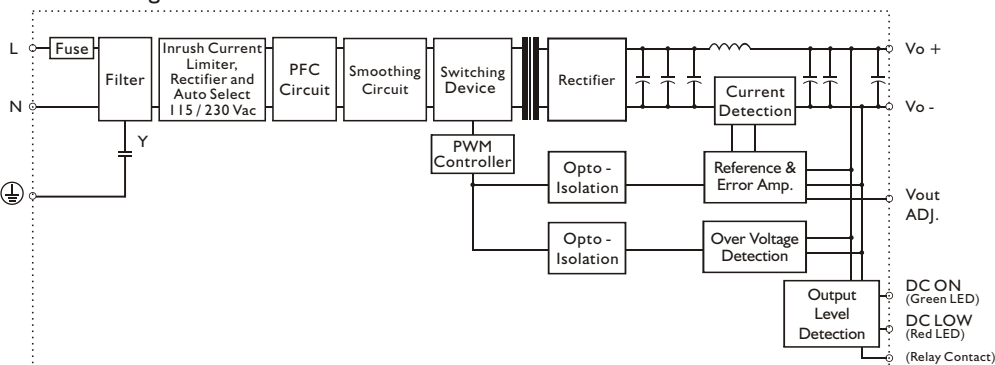

DERATING CURVE

