

UTC TA8229 LINEAR INTEGRATED CIRCUIT

LOW FREQUENCY POWER AMPLIFIER

DESCRIPTION

The UTC TA8229 is an audio power IC with built-in two channels developed for portable radio cassette tape recorder with power ON/OFF switch.

Because of the parts reduction and SIP (Single Inline Package), space merit is remarkable.

Thermal shut down protection circuit is built in.

FEATURES

- * High Power
 - : $P_{out(1)} = 2.5W$ (Typ.)
($V_{CC} = 9V$, $R_L = 4\Omega$, $f = 1kHz$, THD = 10%)
 - : $P_{out(2)} = 4.6W$ (Typ.)
($V_{CC} = 12V$, $R_L = 4\Omega$, $f = 1kHz$, THD = 10%)
- * Low Popping Noise at Power ON
- * Small Quiescent Current
 - : $I_{CCQ} = 21mA$ (Typ.) ($V_{CC} = 15V$, $V_{in} = 0$)
- * Soft Clip
- * Built-in Thermal Shut Down Protection Circuit
- * Best for Supply Voltage 9V, 12V
- * Operation Supply Voltage Range : $V_{CC(opr)} = 6 \sim 15V$
($T_a = 25^\circ C$)

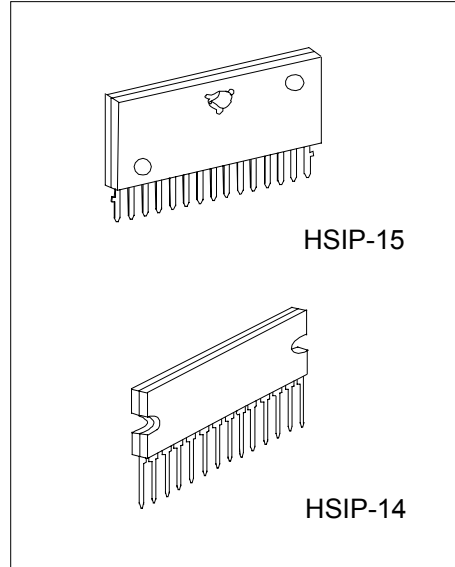

PIN DESCRIPTION

PIN NO.		PIN NAME
HSIP-14	HSIP-15	
	1	NC
1	2	B.S. 2
2	3	OUT 2
3	4	Vcc 1
4	5	OUT 1
5	6	B.S.1
6	7	Power-GND
7	8	Vcc 2
8	9	RIPPLE
9	10	NF1
10	11	IN 1
11	12	IN 2
12	13	NF 2
13	14	Pre-GND 1
14	15	Pre-GND 2

UTC TA8229 LINEAR INTEGRATED CIRCUIT

BLOCK DIAGRAM
HSIP-15

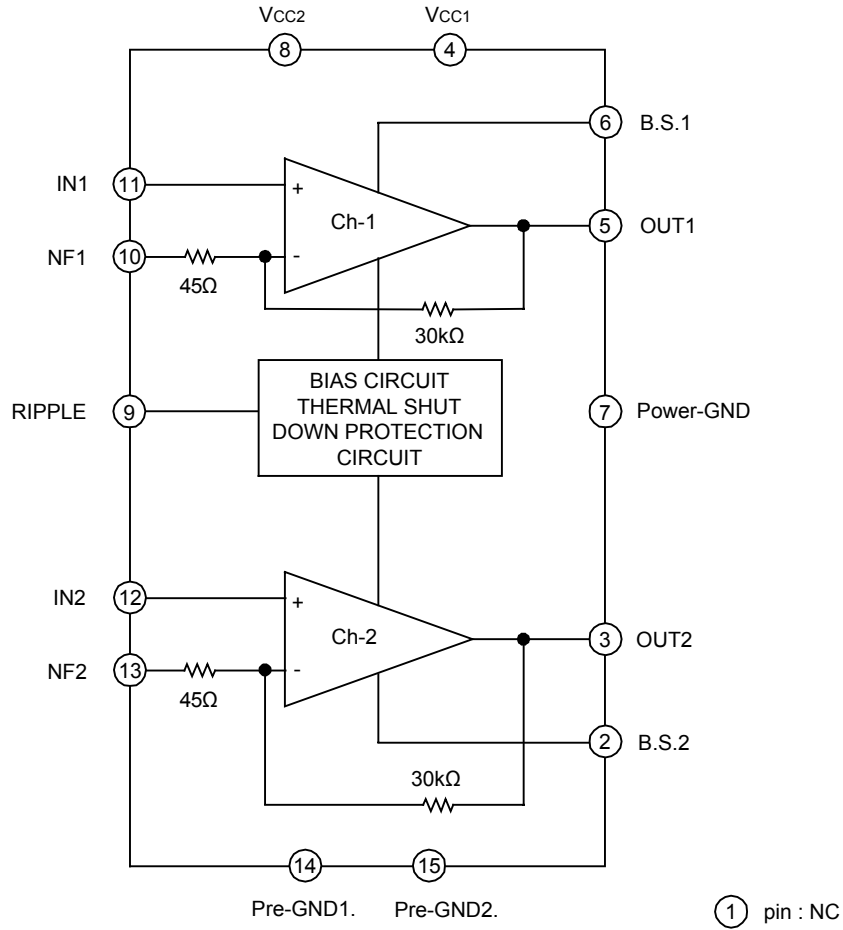

ABSOLUTE MAXIMUM RATINGS (Ta = 25°C)

PARAMETER	SYMBOL	RATINGS	UNIT
Supply Voltage	Vcc	20	V
Output Current (Peak/CH)	IO (peak)	2.5	A
Power Dissipation	Pd (Note)	15.0	W
Operating Temperature	Topr	-20 ~ 75	°C
Storage Temperature	Tstg	-55 ~ 150	°C

Note: Derated above Ta = 25°C in the proportion of 120mW/°C.

UTC TA8229 LINEAR INTEGRATED CIRCUIT

ELECTRICAL CHARACTERISTICS

(V_{CC}=9V, R_L=4Ω, R_g=600Ω, f=1kHz, T_a=25°C, R_f=120Ω, unless otherwise specified.)

PARAMETER	SYMBOL	TEST CONDITIONS	MIN	TYP	MAX	UNIT
Quiescent Current	I _{CCQ}	V _{in} = 0		21	45	mA
Output Power	P _{out} (1)	THD = 10%	2.0	2.5		W
	P _{out} (2)	THD = 10%, V _{CC} = 12V		4.6		
Total Harmonic Distortion	THD	P _{out} = 0.4W/ch		0.2	1.0	%
Voltage Gain	G _v (1)	R _f = 120Ω, V _{out} = 0.775V _{rms} (0dBm)	43	45	47	dB
	G _v (2)	R _f = 0, V _{out} = 0.775V _{rms} (0dBm)		56.5		
Input Resistance	R _{IN}			30		kΩ
Output Noise Voltage	V _{no}	R _g = 10kΩ, BW = 20Hz ~ 20kHz		0.3	1.0	mV _{rms}
Ripple Rejection Ratio	R.R.	R _g = 600Ω, f _{ripple} = 100kHz		-52		dB
Cross Talk	C.T.	R _g = 600Ω, amp1 ↔ 2 V _{out} = 0.775V _{rms} (0dBm)		-50		dB
Input Offset Voltage	V ₁₁ , V ₁₂			30	60	mV
Stand-by Current	I _{OFF}	SW1 → OFF		1		μA

APPLICATION INFORMATION AND APPLICATION METHOD

1. Adjustment of voltage gain

The voltage gain G_v is obtained as follows by R₁, R₂ and R_f in Fig.1.

$$G_v = 20 \log \frac{R_f + R_1 + R_2}{R_f + R_1}$$

When R_f = 0Ω, G_v = 56.5dB (Typ.)

When R_f = 120Ω, G_v = 45dB (Typ.)

By increasing R_f, reduction of G_v is possible. However, since the feedback increase is liable to produce oscillation, it is recommended to use this at 40dB or over.

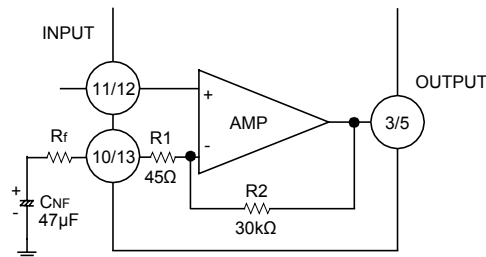

Fig.1

2. Thermal shut-down circuit

The thermal shut-down circuit is built in for the purpose of preventing the destruction of IC due to the abnormal temperature rise when the heat radiation is insufficient.

The operation temperature is set at radiation Fin temperature 175°C (Typ.). At this temperature or over the bias is interrupted to prevent the destruction of IC.

UTC TA8229 LINEAR INTEGRATED CIRCUIT

3. Input stage

The input circuit of this IC is as shown in Fig.2.

PNP Tr: Q1 is provided in the input circuit so as to make its usage possible without the input coupling capacitor.

However, at pin ① and ⑫, max 60 mV offset voltage is produced.

Application after checking volume slide noise is recommended.

For cutting the volume slide noise, insert the input capacitor: C_{IN} in series to interrupt the DC component.

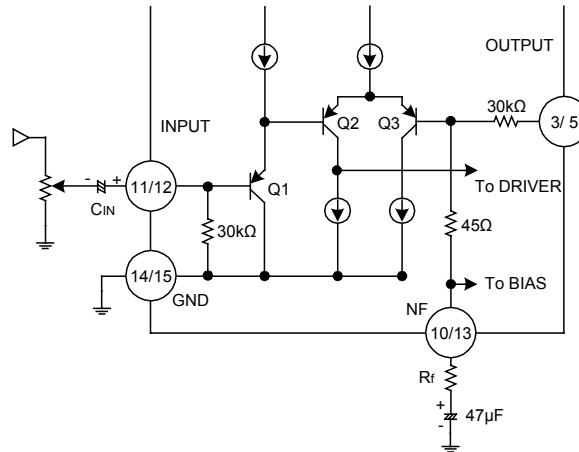

Fig. 2

4. Oscillation preventive measures

For oscillation preventive capacitor C6 and C7 between the output terminal and GND, it is recommended to use polyester film capacitor having good characteristics for temperature and for high frequency.

Since the characteristics of the capacitor is liable to be influenced by the temperature, use this capacitor after the temperature test to check the oscillation allowance.

In addition, as the position of the electrolytic capacitor has a remarkable influence on the oscillation, connect C10 to V_{cc} at the nearest possible position from power GND.

At using this application with the voltage gain reduced, oscillation is liable to be produced. Apply the capacitor after checking enough for its capacity, type and mounting position.

(*) As the oscillation allowance varies according to the printed pattern layout, the standard printed board of TOSHIBA is recommended to be referred to design it.

5. Power ON/OFF switch

There is power ON/OFF switch at ⑧ pin. However, output power is changed by ⑧ pin supply voltage when ⑧ pin supply voltage is not same ④ pin supply voltage, after referring to attached date, select ⑧ pin supply voltage.

6. Input voltage

When the excessive signal is input, turning-up is produced in the clip waveform.

The turning-up point is $V_{in} = 300mV_{rms}$ (Typ.): $V_{cc} = 9V$, $R_L = 4\Omega$, $f = 1kHz$: Enough care must be taken for this phenomenon.

UTC TA8229 LINEAR INTEGRATED CIRCUIT

TEST CIRCUIT

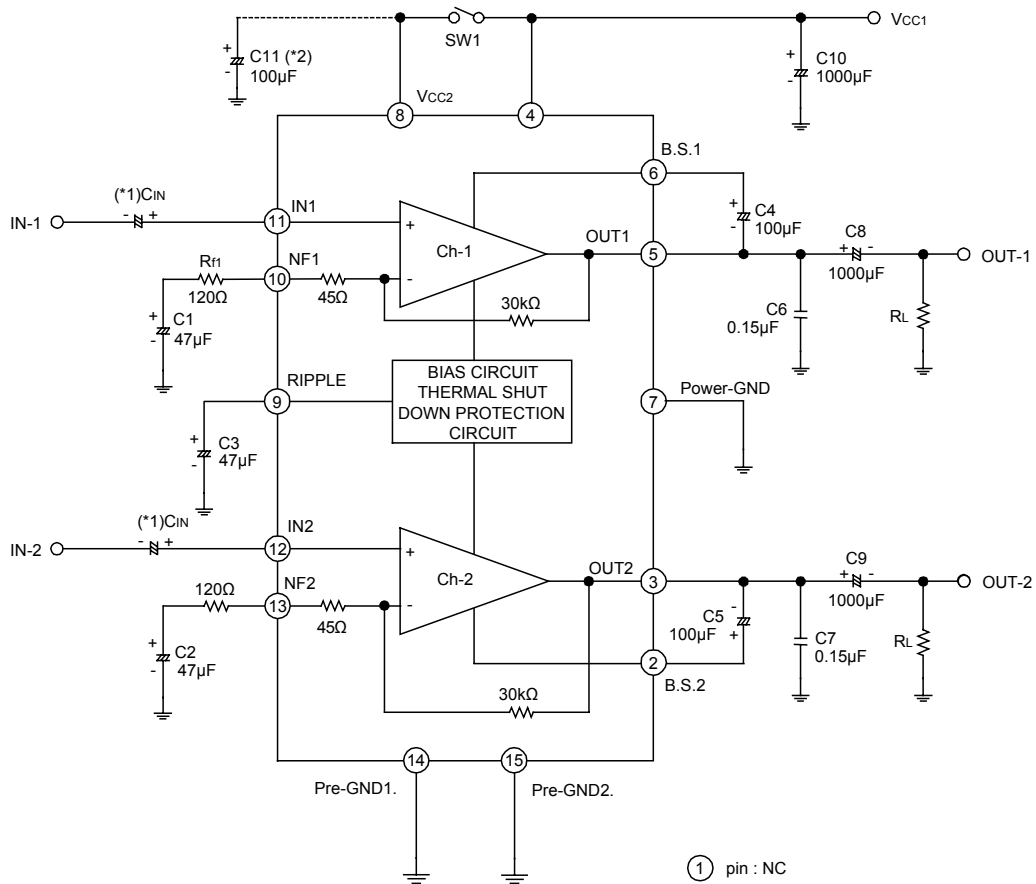

(*1) This IC can be used without coupling capacitor (C_{IN}).

If volume slide noise occurred by input offset voltage is undesirable, it needs to use the capacitor (C_{IN}).

(*2) The condenser between the ⑧pin and the GND (C₁₁) is for reducing POP noise when the power ON/OFF switch (SW1) is set to ON/OFF.

UTC TA8229 LINEAR INTEGRATED CIRCUIT

TYPICAL APPLICATION CIRCUITS

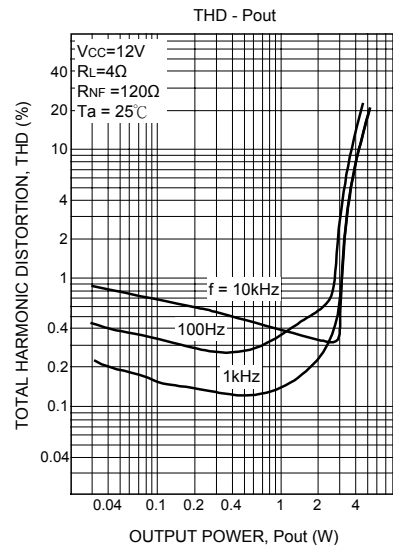
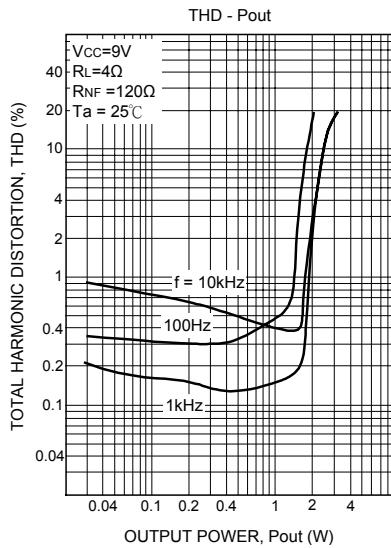
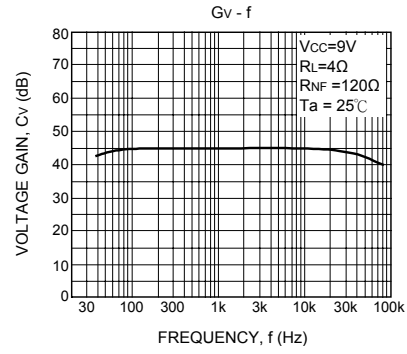
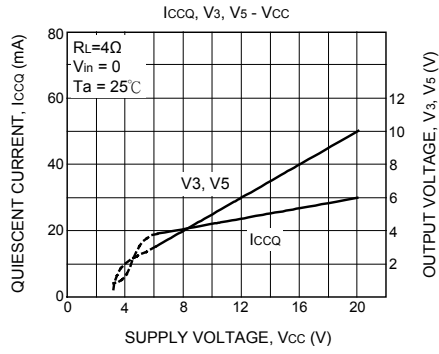

UTC TA8229 LINEAR INTEGRATED CIRCUIT

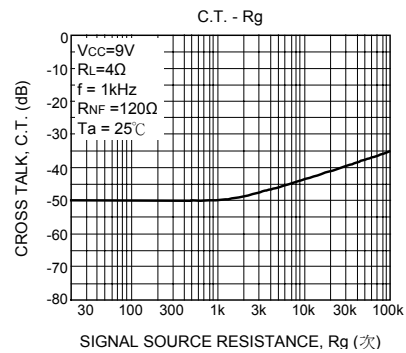
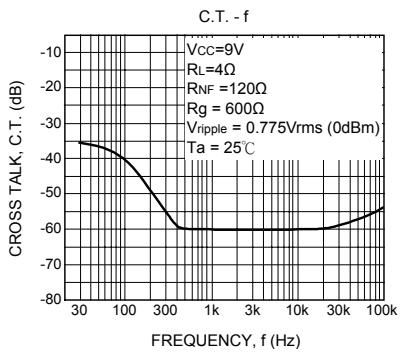
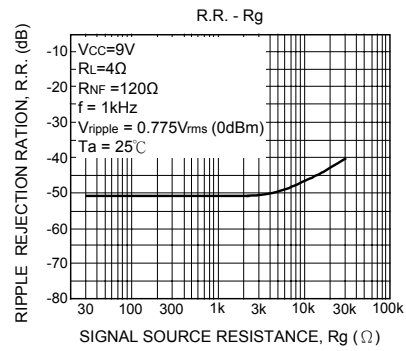
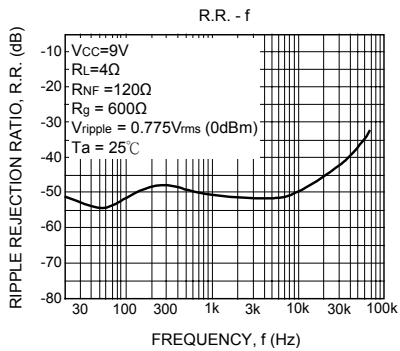
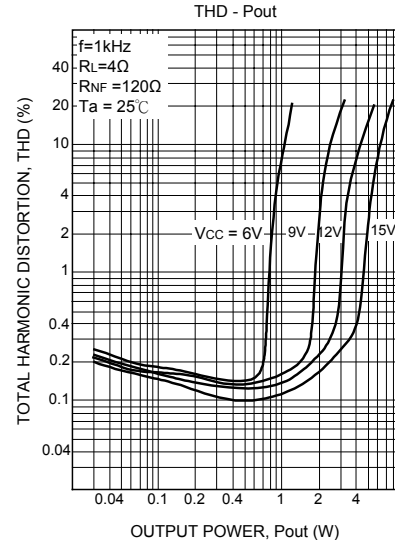
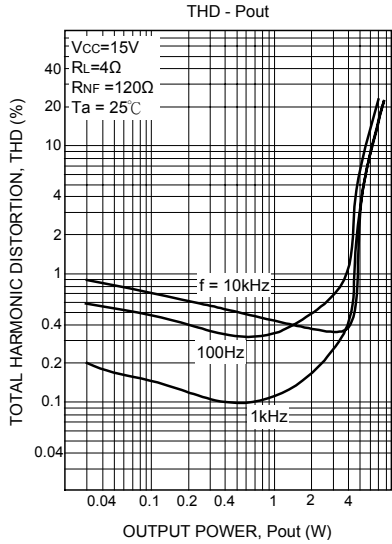

UTC TA8229 LINEAR INTEGRATED CIRCUIT

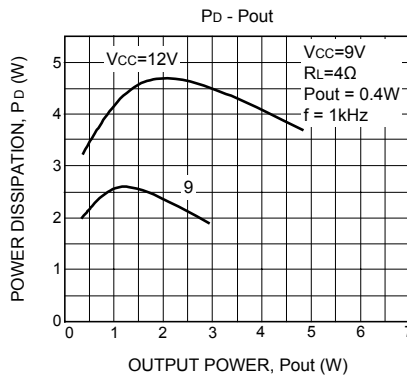
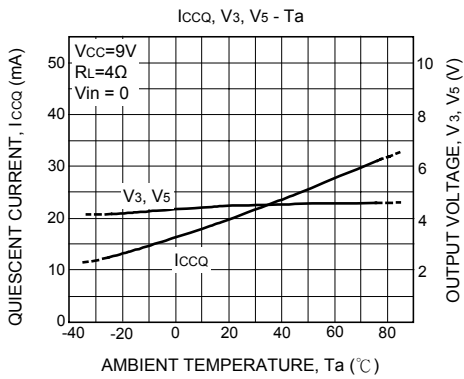
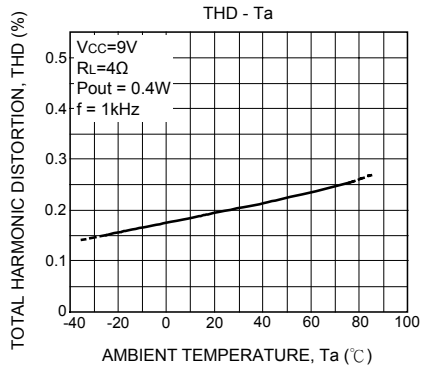
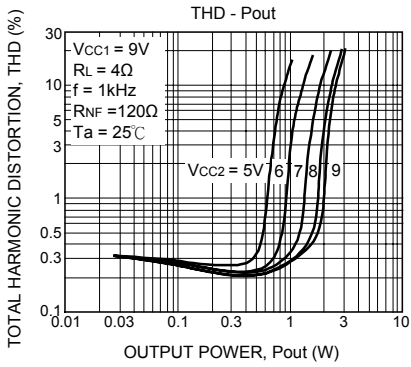
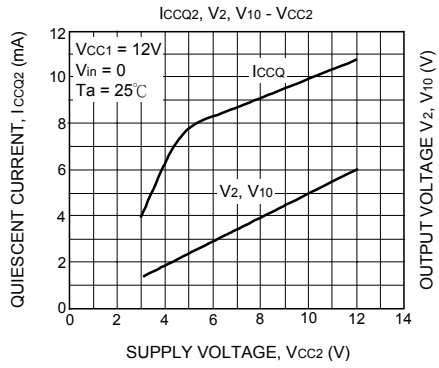
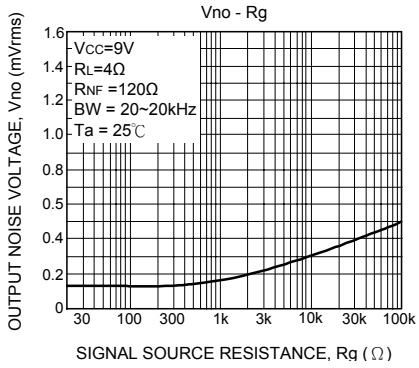

UTC TA8229 LINEAR INTEGRATED CIRCUIT

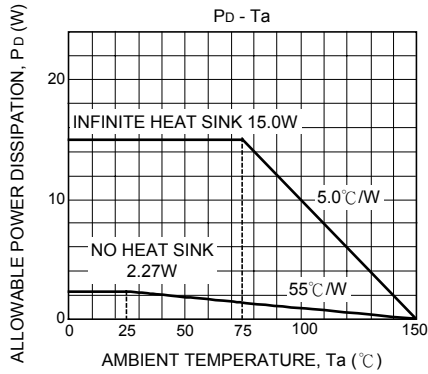

UTC assumes no responsibility for equipment failures that result from using products at values that exceed, even momentarily, rated values (such as maximum ratings, operating condition ranges, or other parameters) listed in products specifications of any and all UTC products described or contained herein. UTC products are not designed for use in life support appliances, devices or systems where malfunction of these products can be reasonably expected to result in personal injury. Reproduction in whole or in part is prohibited without the prior written consent of the copyright owner. The information presented in this document does not form part of any quotation or contract, is believed to be accurate and reliable and may be changed without notice.