



# TAI-SAW TECHNOLOGY CO., LTD.

No. 3, Industrial 2nd Rd., Ping-Chen Industrial District,  
Taoyuan, 324, Taiwan, R.O.C.

TEL: 886-3-4690038 FAX: 886-3-4697532

E-mail: [tstsales@mail.taisaw.com](mailto:tstsales@mail.taisaw.com) Web: [www.taisaw.com](http://www.taisaw.com)

## Product Specifications Approval Sheet

Product Name: SAW IF Filter 55 MHz ( package 13.3mm x 6.5 mm )

TST Parts No.: TB0887A

Customer Parts No.: \_\_\_\_\_

Customer signature required
Company: _____
Division: _____
Approved by : _____
Date: _____

Checked by: \_\_\_\_\_ Kazuma Lee 

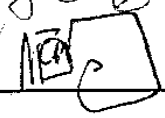
Approval by: \_\_\_\_\_ Francis Chen 

Date: \_\_\_\_\_ 11 / 04 / 2010

1. Customer signed back is required before TST can proceed with sample build and receive orders.
2. Orders received without customer signed back will be regarded as agreement on the specifications.
3. Any specifications changes must be approved upon by both parties and a new revision of specifications shall be released to reflect the changes.



# TAI-SAW TECHNOLOGY CO., LTD.

No.3, Industrial 2nd Rd., Ping-Chen Industrial District, Taoyuan, Taiwan, R.O.C.

TEL: 886-3-4690038 FAX: 886-3-4697532

E-mail: [tstsales3@mail.taisaw.com](mailto:tstsales3@mail.taisaw.com) Web: [www.taisaw.com](http://www.taisaw.com)

SAW Filter 55MHz 0.5MHz BW (SMD 13.3×6.5 mm)

MODEL NO.: TB0887A

REV. NO.1

## A. MAXIMUM RATING:

1. Operating temperature range: -40°C to 85°C
2. Storage temperature range: -40°C to 85°C
3. Input Power Level : 10 dBm
4. Maximum DC Voltage : 10V

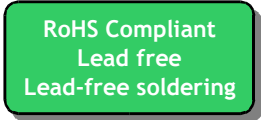

## B. Characteristics :

1. Ambient Temperature: 25 °

Item	Unit	Min.	Type.	Max.
Center frequency, <b>Fc</b>	MHz	-	55	-
Insertion Loss, <b>IL</b>	dB	-	15.4	17
-1.5dB bandwidth	MHz	-	0.5	-
-40dB bandwidth	MHz	-	1.7	2.5
Passband Ripple Fc+/-40KHz	MHz	-	0.1	1.0
Group Delay Variation Fc+/-40KHz	nsec	-	120	170
Absolute Delay	usec	-	1.5	2.2
Temp. Coefficient	ppm/°C <sup>2</sup>	-	-0.036	-
Source Impedance	Ohm	-	50	-
Load Impedance	Ohm	-	50	-

### C. Frequency Characteristics :

(1) Wide band Response:(span 50MHz)

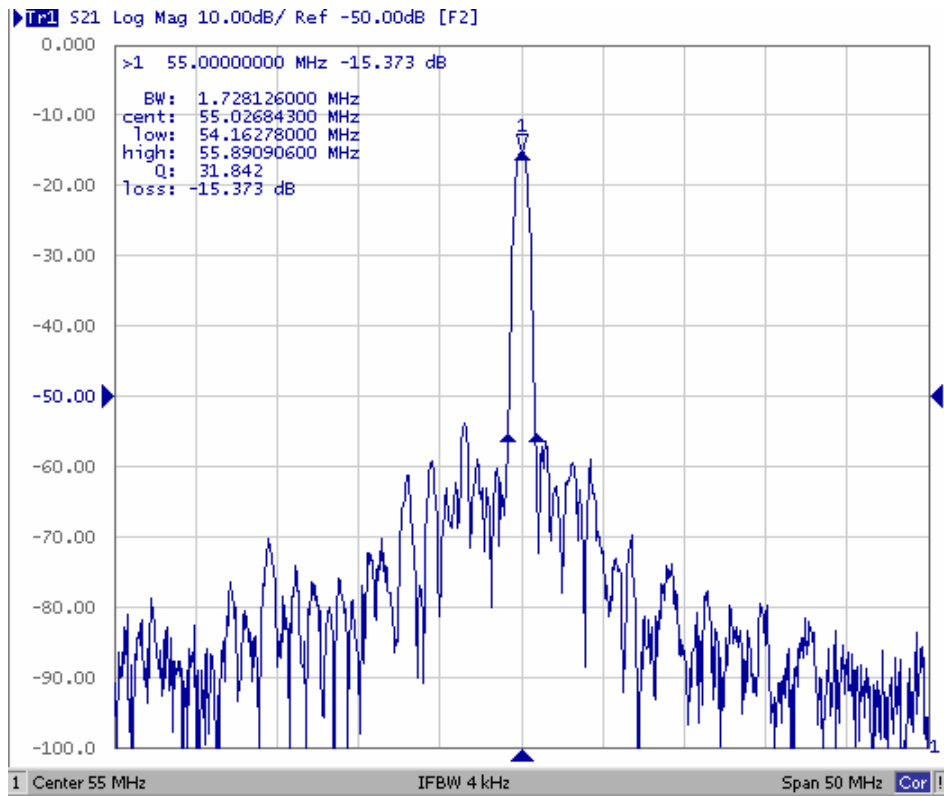

Fig1. Horizontal: 5MHz/Div Vertical: 10dB/Div

(2) Pass band Response and Group Time Delay response:

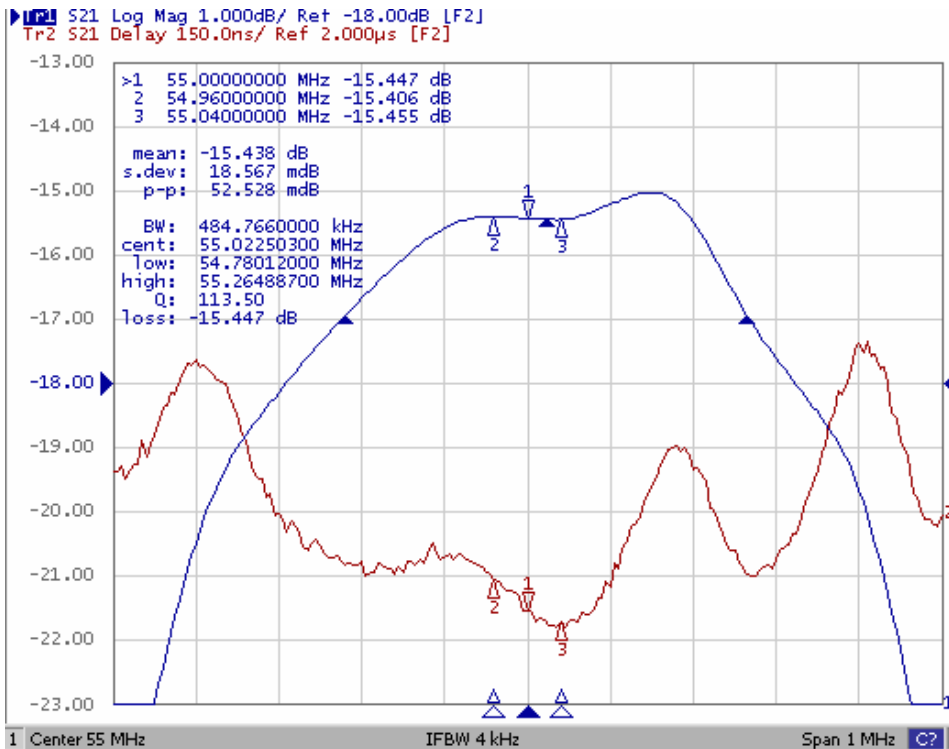
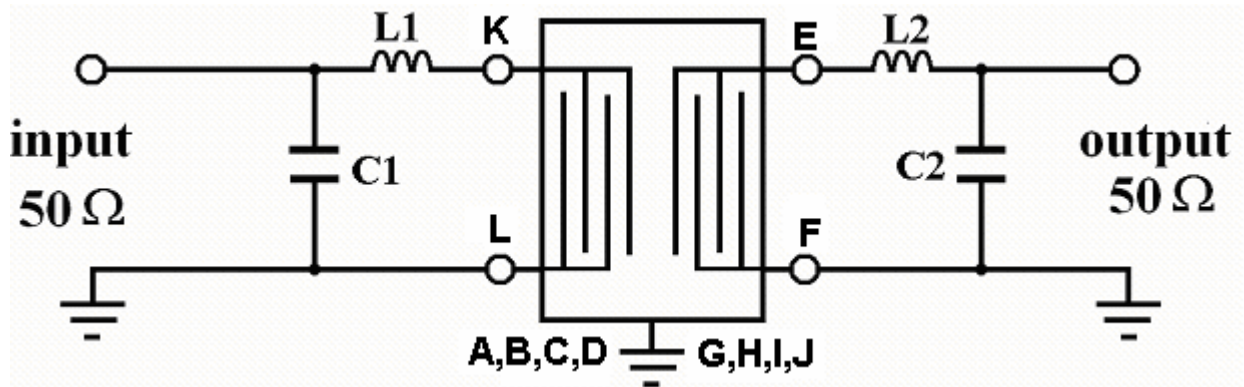

Fig2. Horizontal: 0.1MHz/Div Vertical: 1dB/Div  
Vertical: 150ns/Div

**D. Matching Circuit:**



$$L_{s2}=470\text{nH} + 680\text{nH} \quad L_{s3}=680\text{nH} + 470\text{nH} \quad C_{p1}=56\text{pF} \quad C_{p4}=47\text{pF}$$

**E. Outline Drawing:**

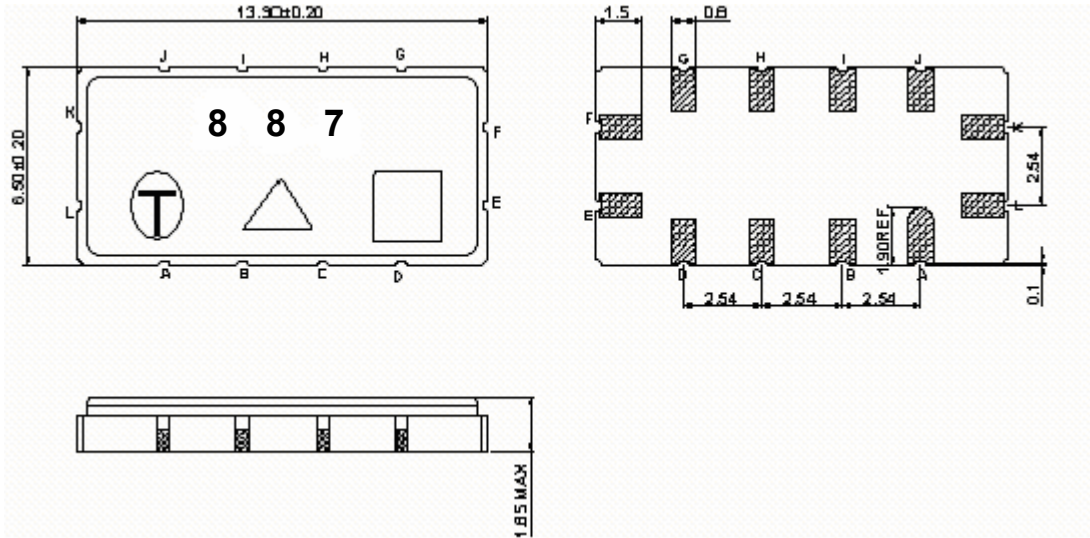

#K : Input

#L : Input Ground

#E : Output

#F : Output Ground

#A,B,C,D,G,H,I,J : Ground

□: Week Code (Follow the table from planner each year)

Unit: mm

△ : Product / Year Code

Year	2009 2013	2010 2014	2011 2015	2012 2016
Product Code	B	b	<u>B</u>	<u>b</u>

## F. PCB Footprint:

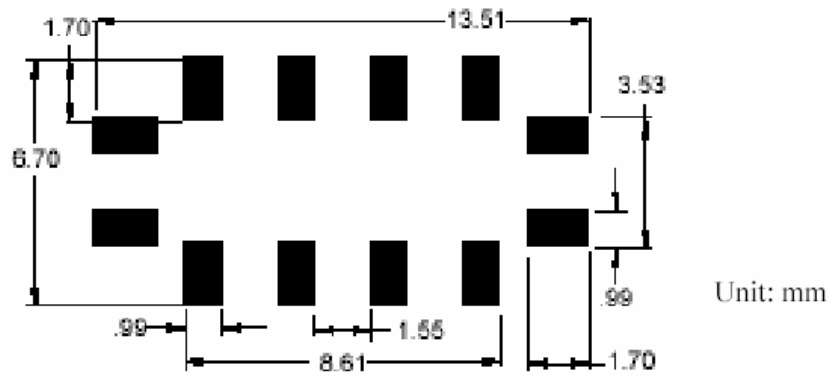

## G. PACKING:

### 1. REEL DIMENSION

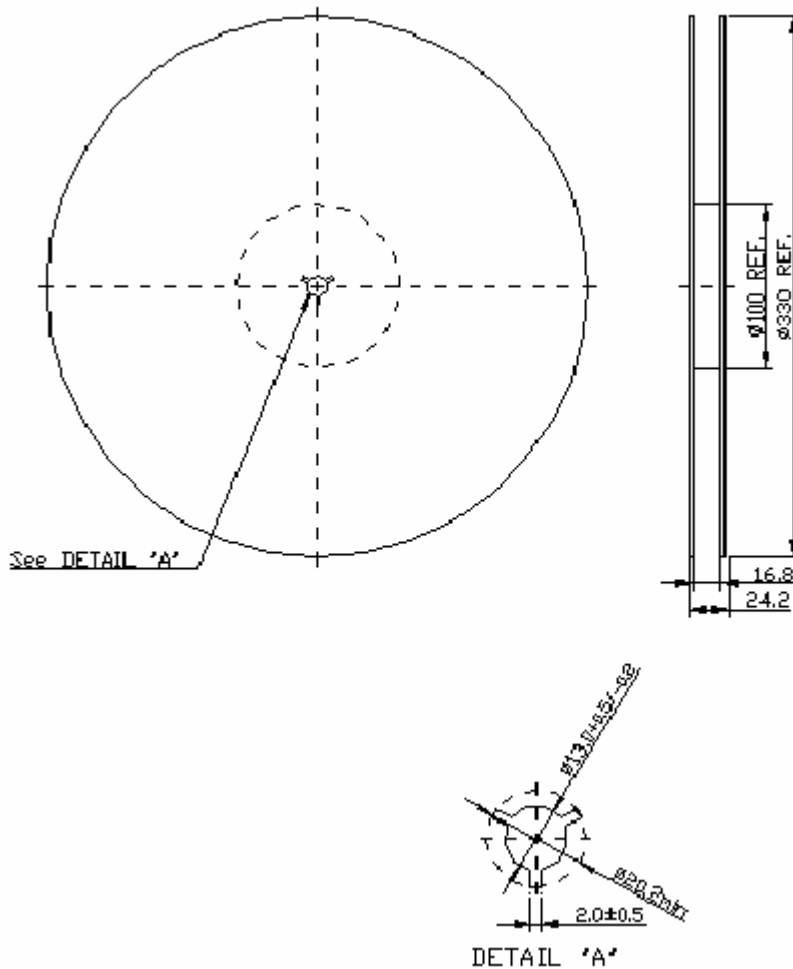

## 2. TAPE DIMENSION

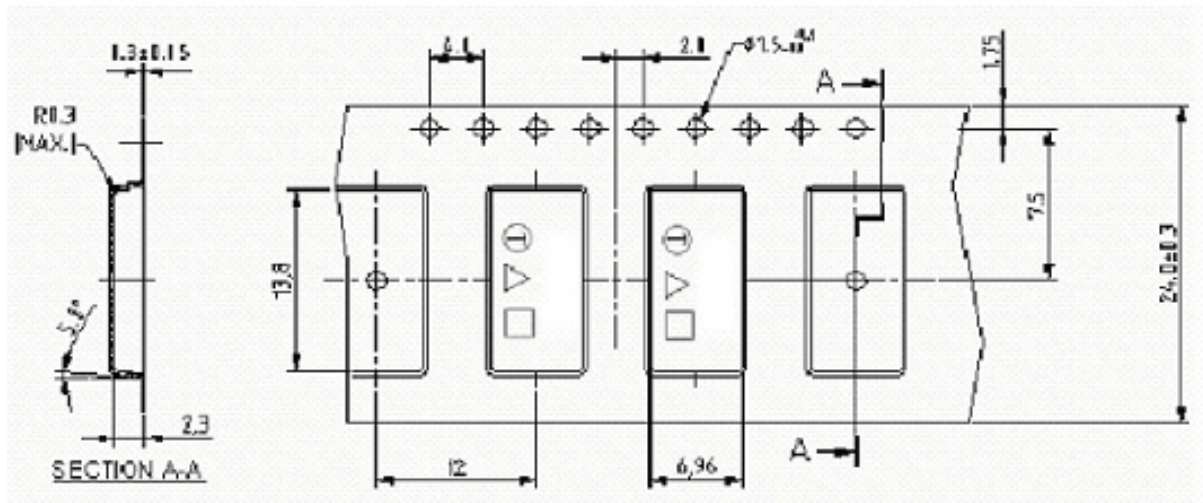

## H. RECOMMENDED REFLOW PROFILE :

