



Size: 0.94in x 0.54in x 0.35in (24mm x 13.7mm x 9mm)

FEATURES

- Low Cost
- RoHS Compliant
- Efficiency up to 75%
- Low Leakage Current
- 4000VAC I/O Isolation
- Water Washable Process Available
- UL/cUL/IEC/EN 60950-1 Safety Approvals and CE Marking
- Single and Dual Outputs
- Tape & Reel Package Available
- Medical EMC Standard meets 4th Edition of EMI EN55011 and EMS EN60601-1-2
- Medical Safety meets 1xMOPP & 2xMOPP per 3rd Edition of IEC/EN 60601-1 & ANSI/AAMI ES60601-1

DESCRIPTION

The MSHU100 series power modules are 2W DC/DC converters that are specially designed to provide ultra-high levels of isolation (4000VAC) in a miniature “gull-wing” SMT package. This series meets IPC/JEDEC J-STD-020C 4th & 5th chapter in solder-reflow for lead free processes. These converters operate over input voltage ranges of 4.5~5.5VDC, 10.8~13.2VDC, and 21.6~26.4VDC. This series also has single and dual output voltages of 5, 12, 15, ±12, and ±15VDC. These converters have both medical and industrial safety approvals and are useful for a variety of applications including distributed power systems, mixed analog/digital subsystems, portable test equipment, local power networks, and battery-backed systems.

MODEL SELECTION TABLE

Single Output Models

Model Number ⁽¹⁾	Input Voltage Range	Output Voltage	Output Current		Input Current		Max Load Regulation	Efficiency	Maximum Capacitive Load	Output Power
			Min.	Max	No Load	Max. Load				
MSHU505N2	5 VDC (4.5 ~ 5.5 VDC)	5 VDC	8mA	400mA	90mA	606mA	12%	66%	330µF	2W
MSHU512N2		12 VDC	3mA	165mA		600mA	10%	66%	330µF	
MSHU515N2		15 VDC	2.5mA	133mA		605mA	10%	66%	330µF	
MSHU1205N2	12 VDC (10.8 ~ 13.2 VDC)	5 VDC	8mA	400mA	40mA	253mA	12%	66%	330µF	2W
MSHU1212N2		12 VDC	3mA	165mA		250mA	10%	66%	330µF	
MSHU1215N2		15 VDC	2.5mA	133mA		252mA	10%	66%	330µF	
MSHU2405N2	24 VDC (21.6 ~ 26.4 VDC)	5 VDC	8mA	400mA	30mA	126mA	12%	66%	330µF	2W
MSHU2412N2		12 VDC	3mA	165mA		125mA	10%	66%	330µF	
MSHU2415N2		15 VDC	2.5mA	133mA		126mA	10%	66%	330µF	

MODEL SELECTION TABLE

Dual Output Models

Model Number ⁽¹⁾	Input Voltage Range	Output Voltage	Output Current		Input Current		Max Load Regulation	Efficiency	Maximum Capacitive Load	Output Power
			Min.	Max	No Load	Max. Load				
MSHU512ND2	5 VDC (4.5 ~ 5.5 VDC)	±12 VDC	±1.5mA	±83mA	90mA	553mA	10%	72%	100µF	2W
MSHU515ND2		±15 VDC	±1mA	±66mA		542mA	10%	73%	100µF	
MSHU1212ND2	12 VDC (10.8 ~ 13.2 VDC)	±12 VDC	±1.5mA	±83mA	40mA	224mA	10%	74%	100µF	2W
MSHU1215ND2		±15 VDC	±1mA	±66mA		220mA	10%	75%	100µF	
MSHU2412ND2	24 VDC (21.6 ~ 26.4 VDC)	±12 VDC	±1.5mA	±83mA	30mA	112mA	10%	74%	100µF	2W
MSHU2415ND2		±15 VDC	±1mA	±66mA		110mA	10%	75%	100µF	

SPECIFICATIONS					
All specifications are based on 25°C, Resistive Load, Nominal Input Voltage, and Rated Output Current unless otherwise noted. We reserve the right to change specifications based on technological advances.					
SPECIFICATION	TEST CONDITIONS	Min	Typ	Max	Unit
INPUT SPECIFICATIONS					
Input Voltage Range	5V nominal input models	4.5	5	5.5	VDC
	12V nominal input models	10.8	12	13.2	
	24V nominal input models	21.6	24	26.4	
Input Surge Voltage (100ms. Max)	5V nominal input models	-0.7		9	VDC
	12V nominal input models	-0.7		18	
	24V nominal input models	-0.7		30	
Input Filter		Internal Capacitor			
Leakage Current	240VAC, 60Hz			2	µA
OUTPUT SPECIFICATIONS					
Output Voltage		See Table			
Voltage Accuracy			±2.0	±4.0	%Vnom
Line Regulation	Vin = min. to max.		±1.2	±1.5	%
Load Regulation	Io = 20% to 100%	See Rating Chart			
Voltage Balance	Dual Output, Balanced Loads		±0.1	±1.0	%
Output Power		See Table			
Output Current		See Table			
Maximum Capacitive Load		See Table			
Ripple & Noise	0-20MHz Bandwidth			150	mVp-p
PROTECTION					
Short Circuit Protection		0.5 seconds max.			
Input Fuse Recommendation	5V nominal input models	1000mA slow-blow type			
	12V nominal input models	500mA slow-blow type			
	24V nominal input models	200mA slow-blow type			
GENERAL SPECIFICATIONS					
Efficiency		See Table			
Switching Frequency		50	80	100	KHz
Isolation Voltage Rated	60 seconds	4000			VAC
Isolation Voltage Test	Flash Test for 1 second	6000			VDC
Isolation Resistance	500VDC	10			GΩ
Isolation Capacitance	100KHz, 1V		15	20	pF
Internal Power Dissipation				650	mW
ENVIRONMENTAL					
Operating Temperature (Ambient)	Natural Convection	-25		+80	°C
Operating Temperature (Case)				+90	°C
Storage Temperature		-50		+125	°C
Humidity	Non-Condensing			95	%
Cooling		Natural convection			
Lead-Free Reflow Solder Process		IPC/JEDEC J-STD-020D.1			
Temperature Coefficient			±0.01	±0.02	%/°C
Moisture Sensitivity Level	IPC/JEDEC J-STD-020D.1	Level 2			
MTBF	MIL-HDBK-217F @ 25°C, Ground Benign	2,000,000			hours
PHYSICAL SPECIFICATIONS					
Weight		0.13oz (3.75g)			
Dimensions (L x W x H)		0.94 x 0.54 x 0.35 inches 24.0 x 13.7 x 9.0 mm			
Case Material		Non-conductive Black Plastic (Flammability to UL 94V-0 rated)			
Pin Material		Phosphor Bronze			
Flammability		UL94V-0			
SAFETY CHARACTERISTICS					
Safety Standards		UL/cUL 60950-1, CSA C22.2 No. 60950-1 ANSI/AAMI ES60601-1, CAN/CSA-C22.2 No. 60601-1 IEC/EN 60950-1, IEC/EN 60601-1 3 rd Edition 1xMOPP & 2xMOPP			
Safety Approvals		UL/cUL 60950-1 Recognition (UL Certificate) IEC/EN 60950-1 (CB Report) ANSI/AAMI ES60601-1 1xMOPP & 2xMOOP recognition (UL Certificate) IEC/EN 60601-1 3 rd Edition (CB Report)			

NOTES

1. The MSHU100 series requires a minimum output loading to maintain specified regulations. Operation under no-load conditions will not damage these devices, however they may not meet all listed specifications.
 2. It is recommended to protect the converter by a slow blow fuse in the input supply line.
 3. Natural convection is about 20LFM but is not equal to still air (0 LFM)
 4. Other input and output voltages may be available, please contact factory
- *Due to advances in technology, specifications subject to change without notice.*

BLOCK DIAGRAMS

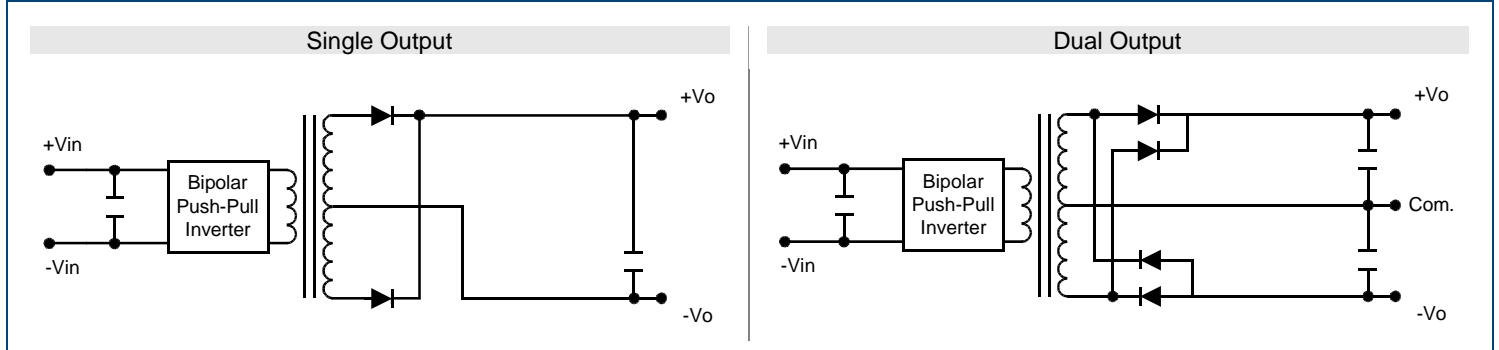

EFFICIENCY GRAPHS

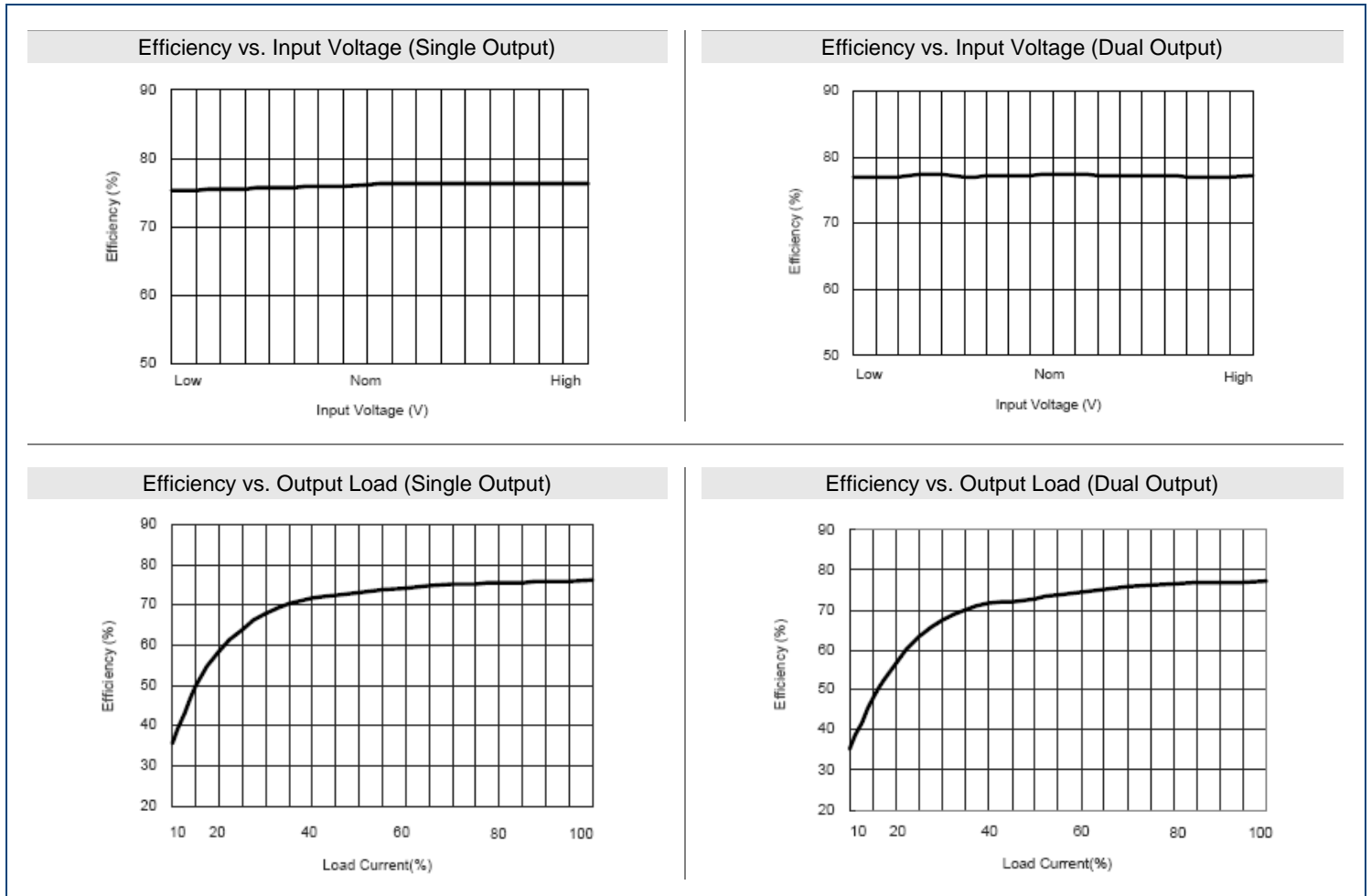

DERATING CURVE

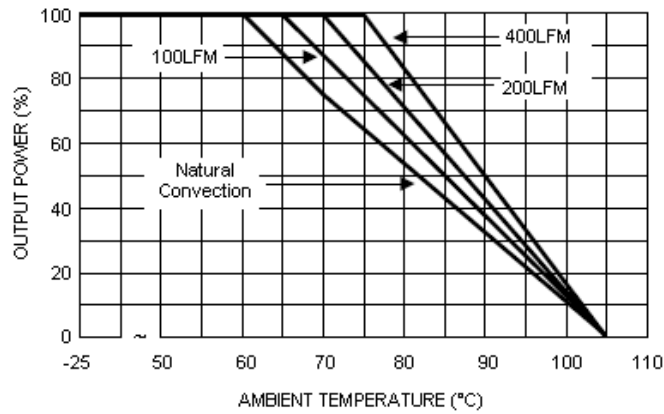

MECHANICAL DRAWINGS

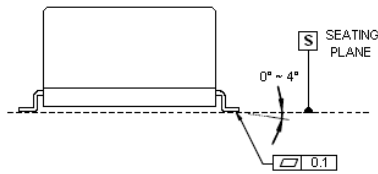
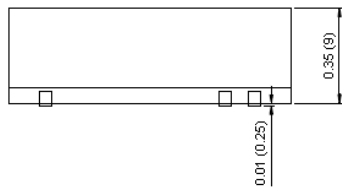
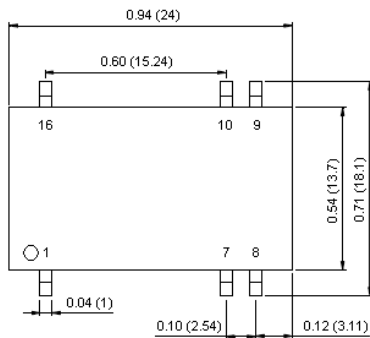

PIN CONNECTIONS		
PIN	Single Output	Dual Output
1	-Vin	-Vin
7	NC	NC
8	NC	Common
9	+Vout	+Vout
10	-Vout	-Vout
16	+Vin	+Vin

NC: No Connection

Connecting Pin Pattern

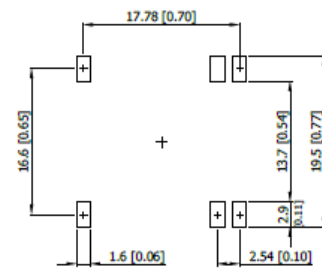

1. Tolerance: X.X±0.25 (X.XX±0.01)
X.XX±0.13 (X.XXX±0.005)
2. Pin: ±0.05 (±0.002)

TEST SETUP

Peak-to-Peak Output Noise Measurement Test

Use a C_{out} 0.47 μ F ceramic capacitor. Scope measurement should be made by using a BNC socket, measurement bandwidth is 0-20MHz. Position the load between 50mm and 75mm from the DC/DC Converter

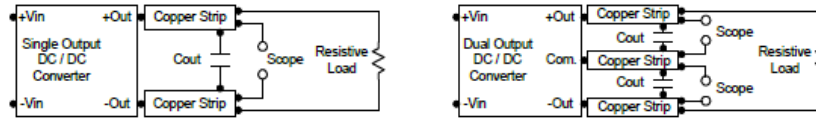

TECHNICAL NOTES

Maximum Capacitive Load

The MSHU100 series has a limit of maximum connected capacitance at the output. The power module may be operated in current limiting mode during start-up, affecting the ramp-up and the startup time. For optimal performance we recommend 100 μ F maximum capacitive load for dual outputs and 330 μ F capacitive load for single outputs. The maximum capacitance can be found in the Model Selection Guide.

Input Source Impedance

The power module should be connected to a low ac-impedance input source. Highly inductive source impedances can affect the stability of the power module. In applications where power is supplied over long lines and output loading is high, it may be necessary to use a capacitor at the input to ensure startup. A capacitor mounted close to the power module helps ensure stability of the unit, it is recommended to use a good quality low Equivalent Series Resistance (ESR < 1.0 Ω at 100KHz) capacitor of 2.2 μ F for the 5V input models, a 1.0 μ F for the 12V input models, and a 0.47 μ F for the 24V input models.

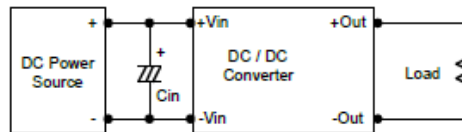

Output Ripple Reduction

A good quality low ESR capacitor placed as close as possible across the load will give the best ripple and noise performance. To reduce output ripple, it is recommended to use 3.3 μ F capacitors at the output.

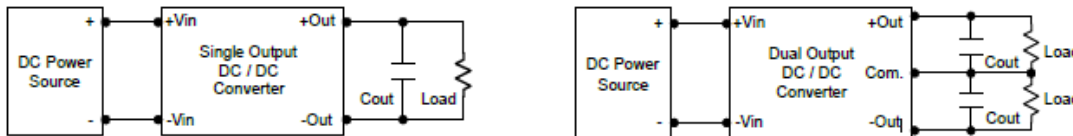

Thermal Considerations

Many conditions affect the thermal performance of the power module, such as orientation, airflow over the module, and board spacing. To avoid exceeding the maximum temperature rating of the components inside the power module, the case temperature must be kept below 105 $^{\circ}$ C. The derating curves are determined from measurements obtained in a test setup.

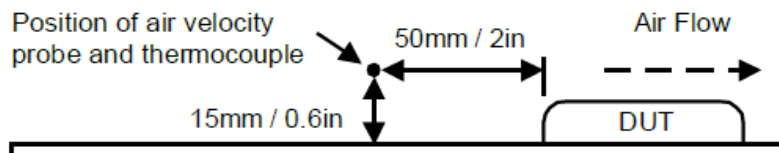

PACKAGING

Reel Taping Package

Unit: mm

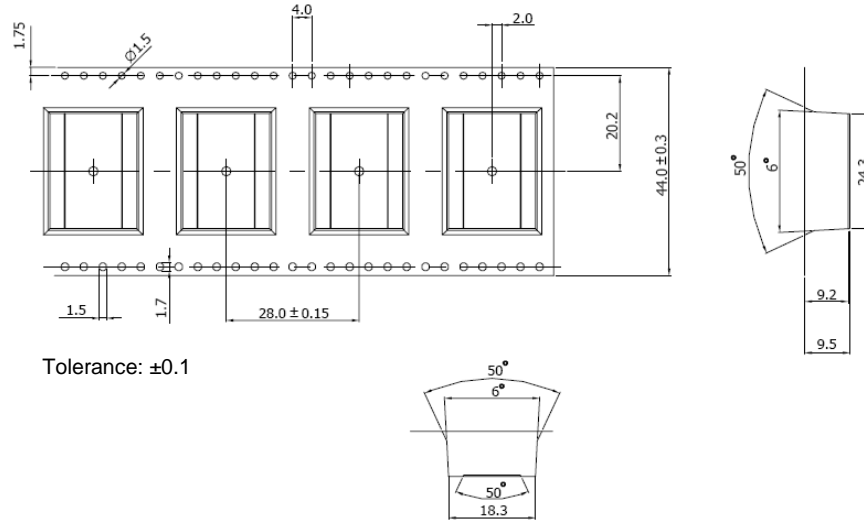

Packaging Specifications

Unit: mm

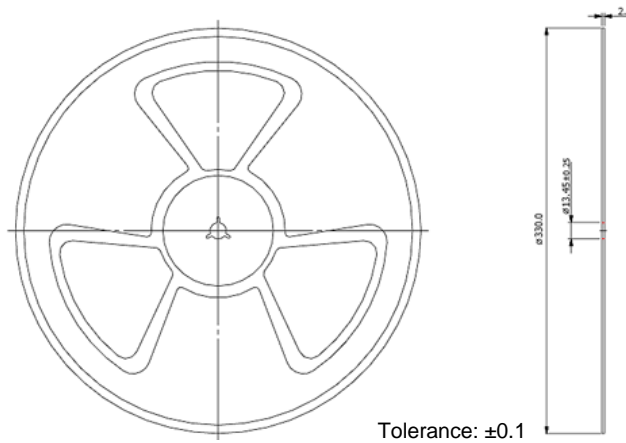

Tube

Unit: mm

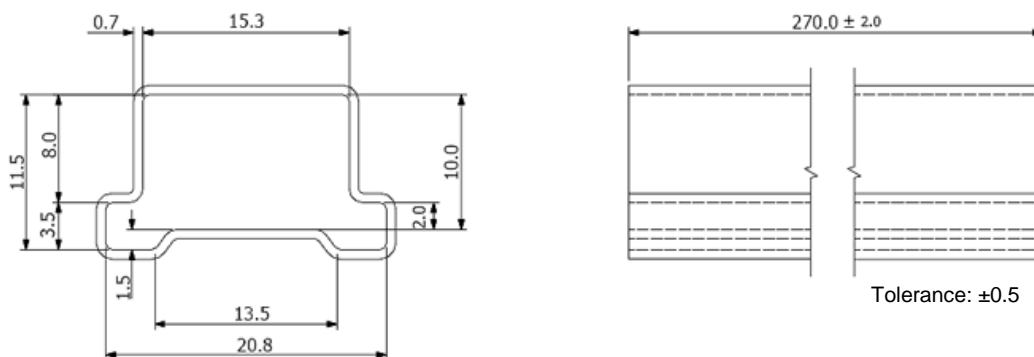

COMPANY INFORMATION

Wall Industries, Inc. has created custom and modified units for over 50 years. Our in-house research and development engineers will provide a solution that exceeds your performance requirements on-time and on budget. Our ISO9001-2008 certification is just one example of our commitment to producing a high quality, well-documented product for our customers.

Our past projects demonstrate our commitment to you, our customer. Wall Industries, Inc. has a reputation for working closely with its customers to ensure each solution meets or exceeds form, fit and function requirements. We will continue to provide ongoing support for your project above and beyond the design and production phases. Give us a call today to discuss your future projects.

Contact **Wall Industries** for further information:

Phone: ☎ (603)778-2300
Toll Free: ☎ (888)597-9255
Fax: ☎ (603)778-9797
E-mail: sales@wallindustries.com
Web: www.wallindustries.com
Address: 37 Industrial Drive
Exeter, NH 03833