

DO NOT SCALE FROM THIS PRINT

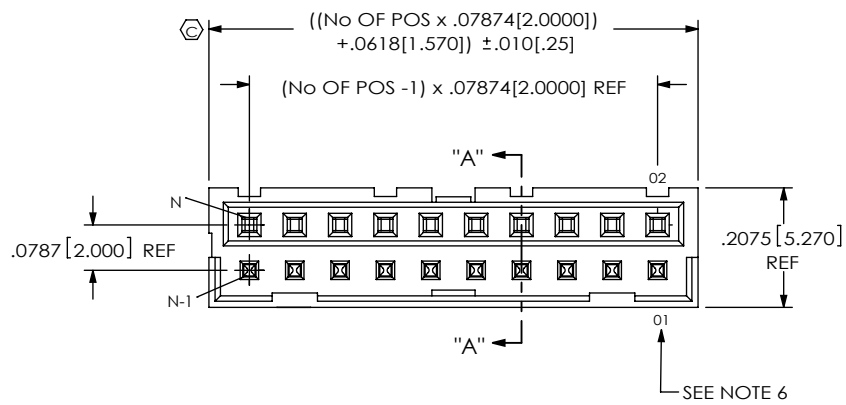
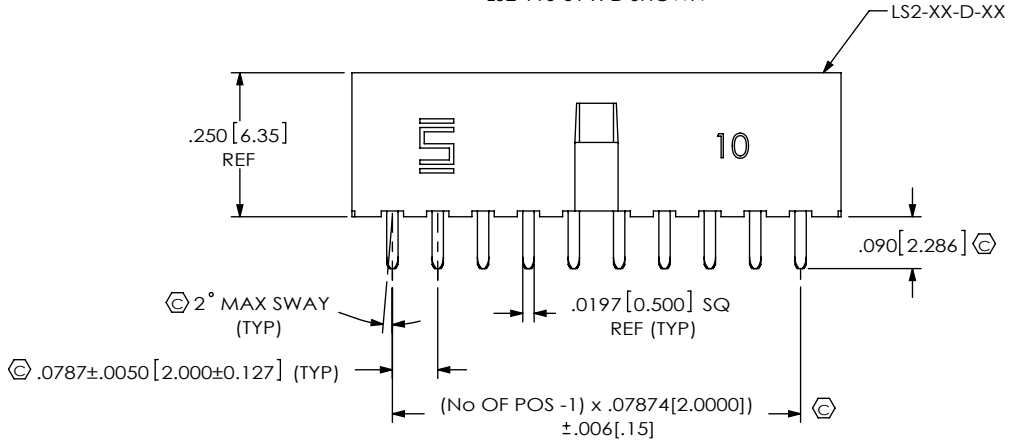

FIG 1
LS2-110-01-X-D SHOWN



LS2-1XX-XX-XX-D-XXX-X

No OF POSITIONS
-05, -10, -15, -20,
-25, -30
(PER ROW)

LEAD STYLE
-01: THROUGH HOLE
-02: SURFACE MOUNT
(SEE FIG 2)

PLATING SPECIFICATION
-F: FLASH SELECTIVE GOLD
(USE T-1S13-XX-F-2 & C-79-XX-F)
-FM: FLASH SELECTIVE GOLD
MATTE TIN REMAINDER
(USE T-1S13-XX-F-2 & C-79-XX-F)
-L: LIGHT SELECTIVE GOLD
(USE T-1S13-XX-L-2 & C-79-XX-L)
-LM: LIGHT SELECTIVE GOLD
MATTE TIN REMAINDER
(USE T-1S13-XX-L-2 & C-79-XX-L)
-S: SELECTIVE GOLD
(USE T-1S13-XX-S-2 & C-79-XX-S)
-SM: SELECTIVE GOLD
MATTE TIN REMAINDER
(USE T-1S13-XX-S-2 & C-79-XX-S)
-G: GOLD
(USE T-1S13-XX-G-2 & C-79-XX-G)
-H: HEAVY GOLD
(USE T-1S13-XX-H-2 & C-79-XX-H)

OPTION
-K: POLYIMIDE FILM PAD
(USE K-DOT-.246-.375-.005, SEE FIG 5)
[LEAD STYLE -02 ONLY]
-A: ALIGNMENT PIN
(USE LS2-XX-D-XX-A, SEE FIG 6)
[LEAD STYLE -02 ONLY]
-TR: TAPE & REEL

TAIL OPTION
-RA1: RIGHT ANGLE-
SHROUD DOWN (SEE FIG 3)
-RA2: RIGHT ANGLE-
SHROUD UP (SEE FIG 4)
[AVAILABLE ONLY ON LEAD STYLE -01]

ROW SPECIFICATION
-D: DOUBLE (USE LS2-XX-D-XX)

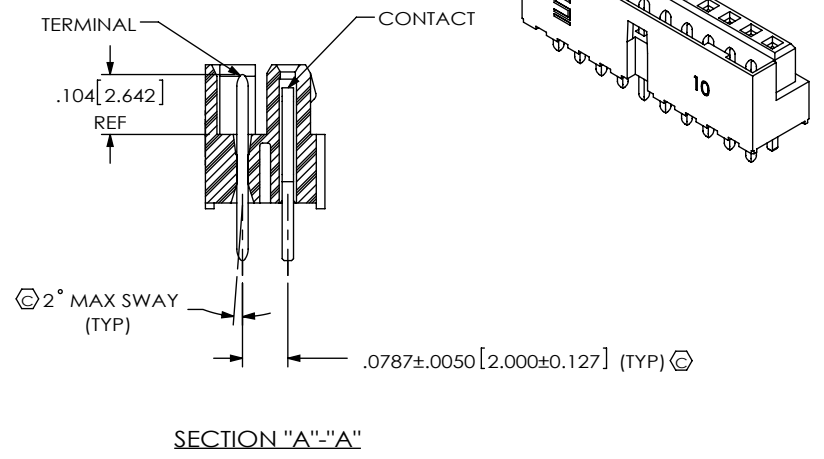

STYLE	OPTION	TERMINAL	CONTACT
-01	---	T-1S13-20-XXX-2	C-79-01-XXX
	-RA1	T-1S13-03-XXX-2	C-79-12-XXX
	-RA2	T-1S13-10-XXX-2	C-79-12-XXX
-02	---	T-1S13-13-XXX-2	C-79-12-XXX

- NOTES:
1. ⊕ REPRESENTS A CRITICAL DIMENSION.
 2. BURR ALLOWANCE: .003[.08] MAX.
 3. MAXIMUM CUT FLASH: .015[.38].
 4. MINIMUM PUSHOUT FORCE: TERMINALS: 2 LBS., CONTACTS: .5 LBS.
 5. MAXIMUM ALLOWABLE BOW: .002 INCH/INCH AFTER ASSEMBLY.
 6. SEE APPLICATION VIEWS (SHEET 3) FOR POSITION 01 LOCATION.
 7. ALL PIN TO PIN DIMENSIONS TO BE MEASURED FROM TIP TO TIP.
 8. DIMENSION TO BE MEASURED AT BEND.
 9. SHEAR TAILS TO DIMENSION SHOWN.

<p>UNLESS OTHERWISE SPECIFIED, DIMENSIONS ARE IN INCHES.</p> <p>TOLERANCES ARE:</p> <p>DECIMALS ANGLES</p> <p>.XX: ±.01 [.3] 2°</p> <p>.XXX: ±.005 [.13]</p> <p>.XXXX: ±.0020 [.051]</p>	<p>PROPRIETARY NOTE</p> <p>THIS DOCUMENT CONTAINS CONFIDENTIAL AND PROPRIETARY INFORMATION AND ALL DESIGN, MANUFACTURING, REPRODUCTION, USE, PATENT RIGHTS AND SALES RIGHTS ARE EXPRESSLY RESERVED BY SAMTEC, INC. THIS DOCUMENT SHALL NOT BE DISCLOSED, IN WHOLE OR PART, TO ANY UNAUTHORIZED PERSON OR ENTITY NOR REPRODUCED, TRANSFERRED OR INCORPORATED IN ANY OTHER PROJECT IN ANY MANNER WITHOUT THE EXPRESS WRITTEN CONSENT OF SAMTEC, INC.</p>	<p>520 PARK EAST BLVD, NEW ALBANY, IN 47150 PHONE: 812-944-6733 FAX: 812-948-5047 e-Mail: info@SAMTEC.com code: 55322</p>
<p>C:\EnterpriseVault\DWG\MISC\MKTG\LS2-1XX-XX-XX-D-XXX-X-MKT.SLDDRW</p>		<p>BY: DEAN P 4/24/2002 SHEET 1 OF 4</p>

REVISION V

FIG 2

LS2-110-02-X-D SHOWN
[DIFFERENT AS SHOWN, OTHERWISE SAME AS FIG. 1]

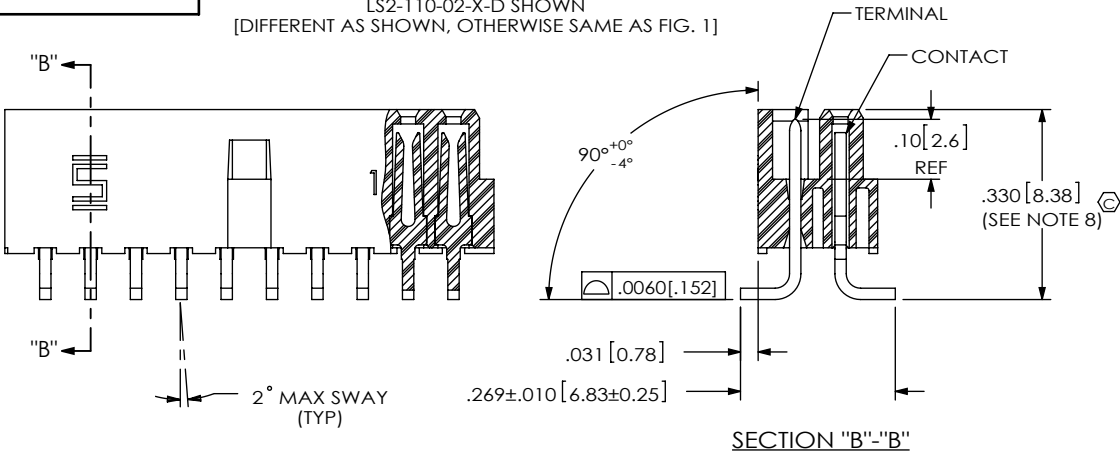

STYLE -02-D IN-PROCESS VIEWS

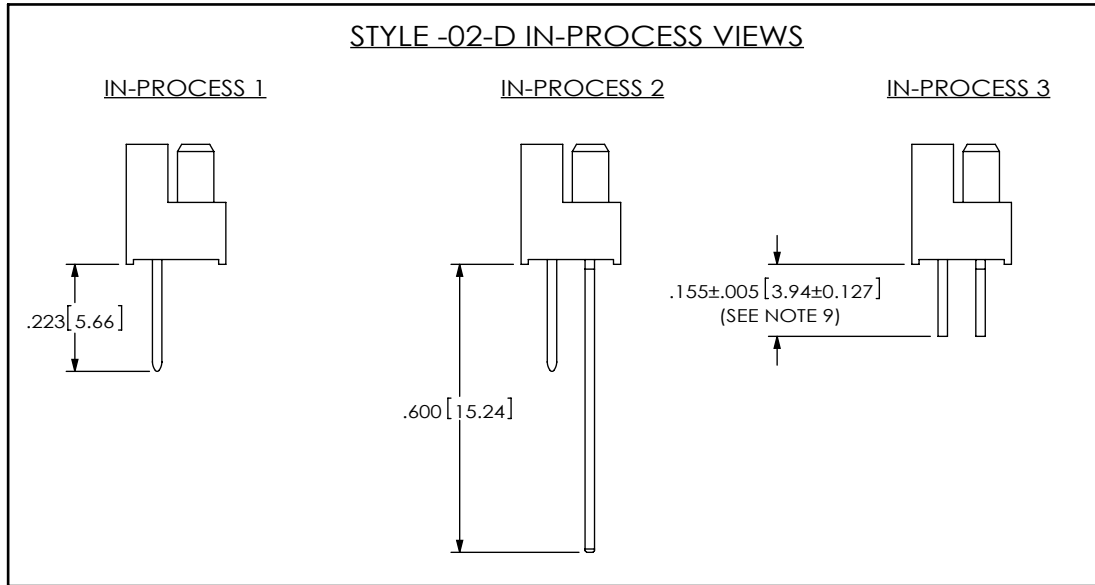
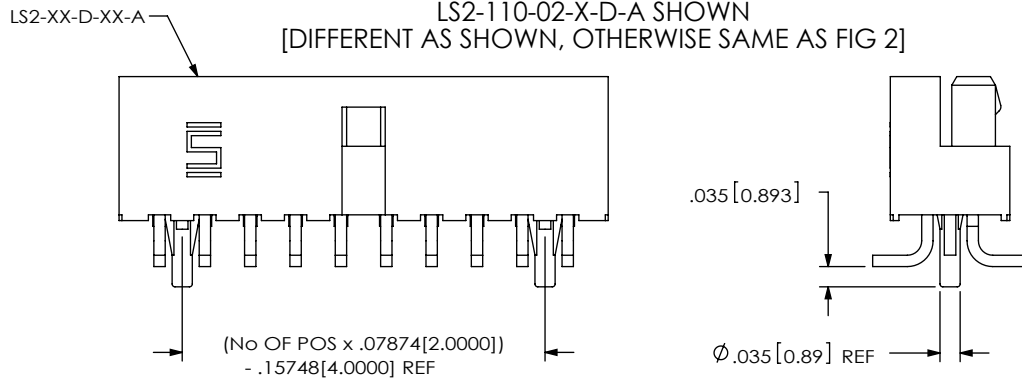

FIG 6

-A: ALIGNMENT PIN OPTION
LS2-110-02-X-D-A SHOWN
[DIFFERENT AS SHOWN, OTHERWISE SAME AS FIG 2]



C:\EnterpriseVault\DWG\MISC\MKTG\LS2-1XX-XX-XX-D-XXX-X-MKT.SLDDRW

PACKAGING VIEWS

STYLE -01

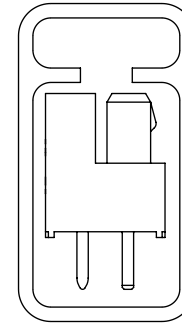

TUBE: PT-1-24-04-09
PLUG: TP-07

STYLE -02

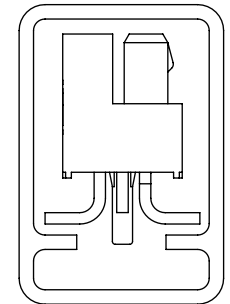

TUBE: PT-1-24-01-123
PLUG: TP-03

STYLE -01-RA1

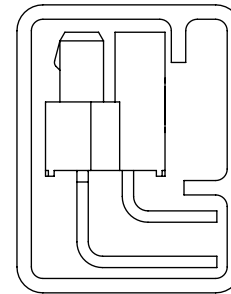

TUBE: PT-1-24-01-124
PLUG: TP-07

STYLE -01-RA2

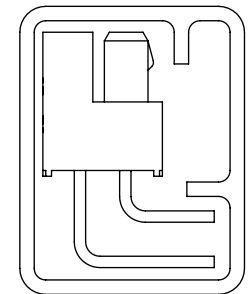

TUBE: PT-1-24-01-124
PLUG: TP-07

PROPRIETARY NOTE
THIS DOCUMENT CONTAINS CONFIDENTIAL AND PROPRIETARY INFORMATION AND ALL DESIGN, MANUFACTURING, REPRODUCTION, USE, PATENT RIGHTS AND SALES RIGHTS ARE EXPRESSLY RESERVED BY SAMTEC, INC. THIS DOCUMENT SHALL NOT BE DISCLOSED, IN WHOLE OR PART, TO ANY UNAUTHORIZED PERSON OR ENTITY NOR REPRODUCED, TRANSFERRED OR INCORPORATED IN ANY OTHER PRODUCT IN ANY MANNER WITHOUT THE EXPRESS WRITTEN CONSENT OF SAMTEC, INC.

DO NOT SCALE DRAWING

SHEET SCALE: 3:1



520 PARK EAST BLVD, NEW ALBANY, IN 47150
PHONE: 812-944-6733 FAX: 812-948-5047
e-Mail: info@SAMTEC.com code: 55322

DESCRIPTION: 2mm TERMINAL/SOCKET COMBO

DWG. NO. LS2-1XX-XX-XX-D-XXX-X

BY: DEAN P 4/24/2002 SHEET 2 OF 4

REVISION V

IN-PROCESS 1

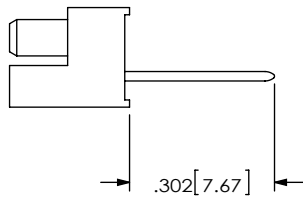

IN-PROCESS 2

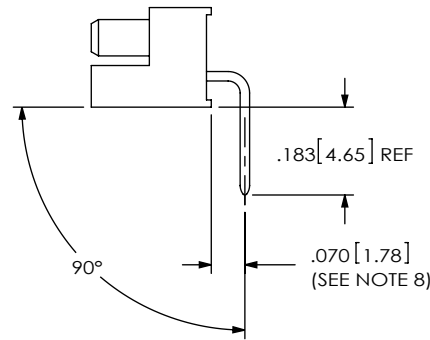

IN-PROCESS 3

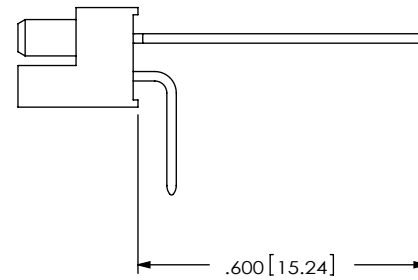

IN-PROCESS 4

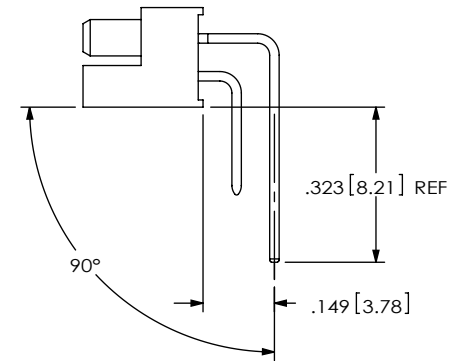

STYLE -01-RA1 IN-PROCESS VIEWS

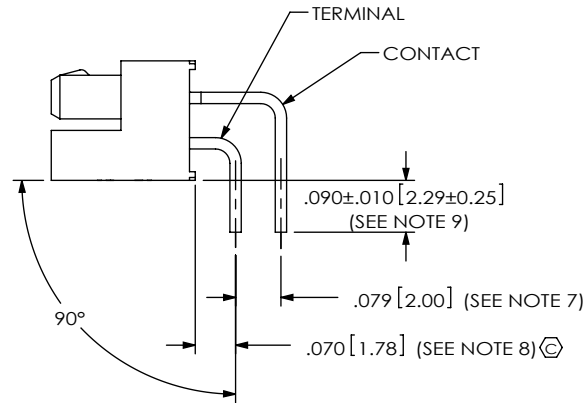
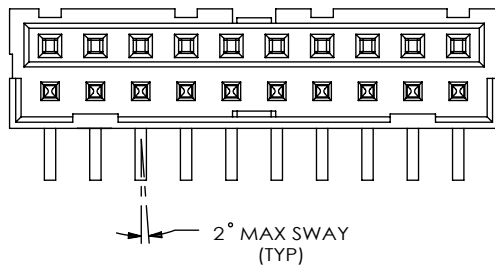
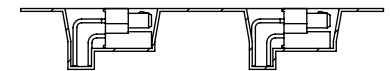
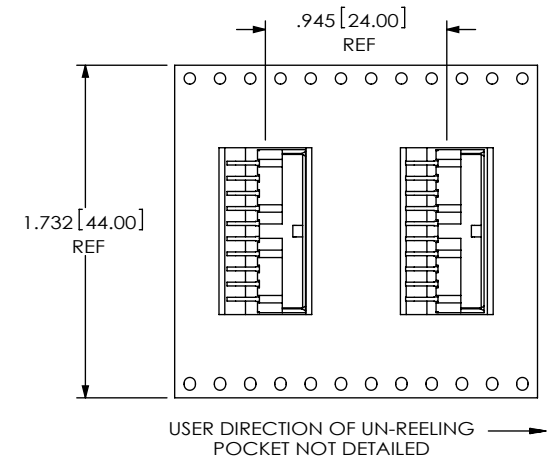
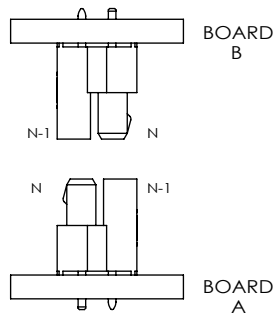

FIG 3
LS2-110-01-X-D-RA1 SHOWN
[DIFFERENT AS SHOWN, OTHERWISE SAME AS FIG 1]
* AVAILABLE ONLY ON LEAD STYLE -01 *



STYLE-01-RA1 PACKAGING VIEW
PARTS MUST BE ORIENTED PER THE DESIGN OF THE POCKET AND POCKET TOOL.
POCKETS DESIGNED AFTER REVISION Q MUST ORIENT PARTS PER THIS VIEW.

APPLICATION VIEWS



PARALLEL BOARD-TO-BOARD

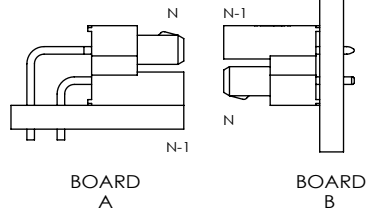

PERPENDICULAR BOARD-TO-BOARD

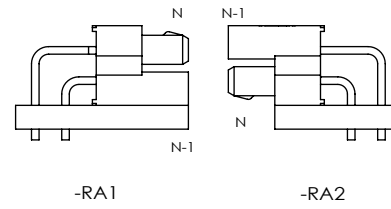

IN-LINE PARALLEL BOARD-TO-BOARD

C:\EnterpriseVault\DWG\MISC\MKTG\LS2-1XX-XX-XX-D-XXX-X-MKT.SLDRW

PROPRIETARY NOTE
THIS DOCUMENT CONTAINS CONFIDENTIAL AND PROPRIETARY INFORMATION AND ALL DESIGN, MANUFACTURING, REPRODUCTION, USE, PATENT RIGHTS AND SALES RIGHTS ARE EXPRESSLY RESERVED BY SAMTEC, INC. THIS DOCUMENT SHALL NOT BE DISCLOSED, IN WHOLE OR PART, TO ANY UNAUTHORIZED PERSON OR ENTITY NOR REPRODUCED, TRANSFERRED OR INCORPORATED IN ANY OTHER PROJECT IN ANY MANNER WITHOUT THE EXPRESS WRITTEN CONSENT OF SAMTEC, INC.

DO NOT SCALE DRAWING

SHEET SCALE: 3:1

samtec

520 PARK EAST BLVD, NEW ALBANY, IN 47150
PHONE: 812-944-6733 FAX: 812-948-5047
e-Mail: info@SAMTEC.com code: 55322

DESCRIPTION:
2mm TERMINAL/SOCKET COMBO
DWG. NO.
LS2-1XX-XX-XX-D-XXX-X

BY: DEAN P 4/24/2002 SHEET 3 OF 4

IN-PROCESS 1

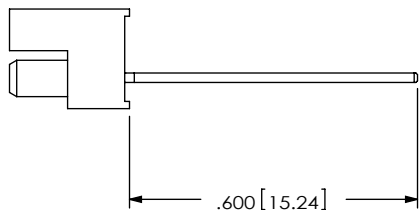

IN-PROCESS 2

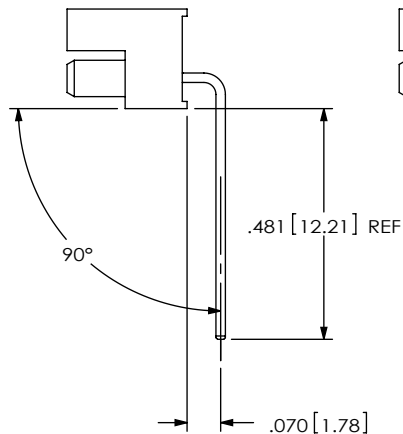

IN-PROCESS 3

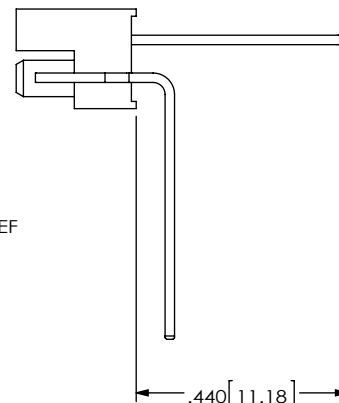

IN-PROCESS 4

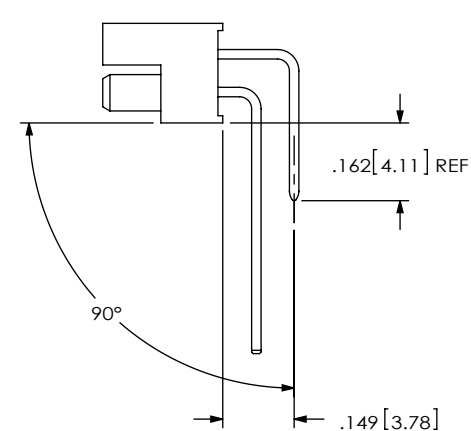

STYLE -01-RA2 IN-PROCESS VIEWS

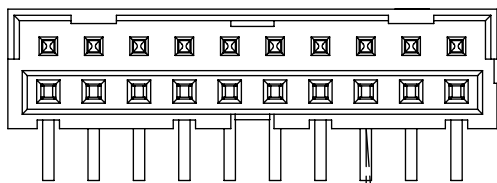

2° MAX SWAY (TYP)

FIG 4

LS2-110-01-X-D-RA2 SHOWN [DIFFERENT AS SHOWN, OTHERWISE SAME AS FIG 1]

* AVAILABLE ONLY ON LEAD STYLE -01 *

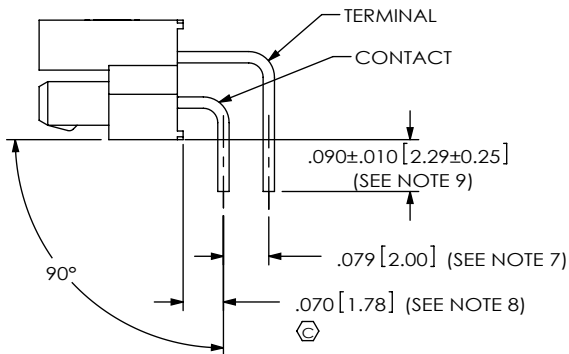
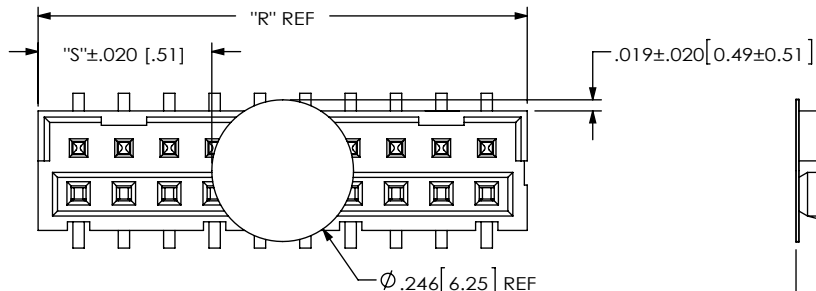
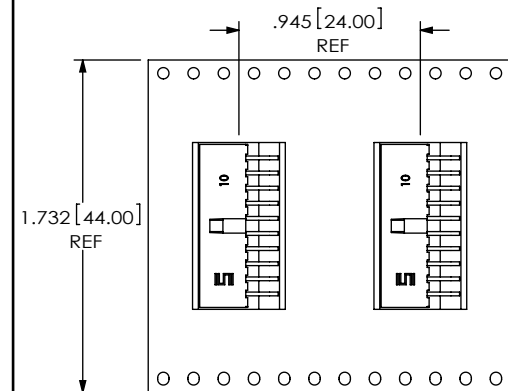

FIG 5
-K: POLYIMIDE FILM PAD OPTION



NOTE:
"R" = (No OF POS x .07874[2.0000]) +.06181[1.570]
"S" = ("R" - .2460[6.248]) / 2



USER DIRECTION OF UN-REELING POCKET NOT DETAILED

STYLE-01-RA2 PACKAGING VIEW
PARTS MUST BE ORIENTED PER THE DESIGN OF THE POCKET AND POCKET TOOL.
POCKETS DESIGNED AFTER REVISION Q MUST ORIENT PARTS PER THIS VIEW.

PROPRIETARY NOTE
THIS DOCUMENT CONTAINS CONFIDENTIAL AND PROPRIETARY INFORMATION AND ALL DESIGN, MANUFACTURING, REPRODUCTION, USE, PATENT RIGHTS AND SALES RIGHTS ARE EXPRESSLY RESERVED BY SAMTEC, INC. THIS DOCUMENT SHALL NOT BE DISCLOSED, IN WHOLE OR PART, TO ANY UNAUTHORIZED PERSON OR ENTITY NOR REPRODUCED, TRANSFERRED OR INCORPORATED IN ANY OTHER PROJECT IN ANY MANNER WITHOUT THE EXPRESS WRITTEN CONSENT OF SAMTEC, INC.
DO NOT SCALE DRAWING
SHEET SCALE: 3:1

samtec
520 PARK EAST BLVD, NEW ALBANY, IN 47150
PHONE: 812-944-6733 FAX: 812-948-5047
e-Mail: info@SAMTEC.com code: 55322

DESCRIPTION:
2mm TERMINAL/SOCKET COMBO
DWG. NO.
LS2-1XX-XX-XX-D-XXX-X
BY: DEAN P 4/24/2002 SHEET 4 OF 4