

isc N-Channel MOSFET Transistor

9N50

• DESCRIPTION

- Drain Current $I_D = 9A @ T_C = 25^\circ C$
- Drain Source Voltage-
: $V_{DSS} = 500V(\text{Min})$
- Fast Switching Speed

• APPLICATIONS

- General purpose power amplifier

• ABSOLUTE MAXIMUM RATINGS($T_C = 25^\circ C$)

SYMBOL	PARAMETER	VALUE	UNIT
V_{DSS}	Drain-Source Voltage ($V_{GS} = 0$)	500	V
V_{GS}	Gate-Source Voltage	± 20	V
I_D	Drain Current-continuous@ $T_C = 25^\circ C$	9	A
$I_{D(\text{puls})}$	Pulse Drain Current	36	A
P_{tot}	Total Dissipation@ $T_C = 25^\circ C$	44	W
T_j	Max. Operating Junction Temperature	150	$^\circ C$
T_{stg}	Storage Temperature Range	-55~150	$^\circ C$

• THERMAL CHARACTERISTICS

SYMBOL	PARAMETER	MAX	UNIT
$R_{\text{th j-c}}$	Thermal Resistance, Junction to Case	1.67	$^\circ C/W$

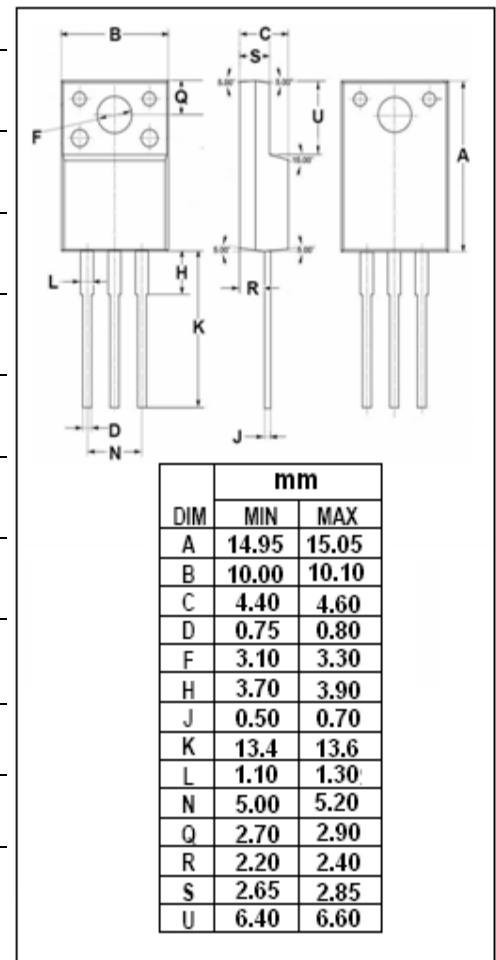
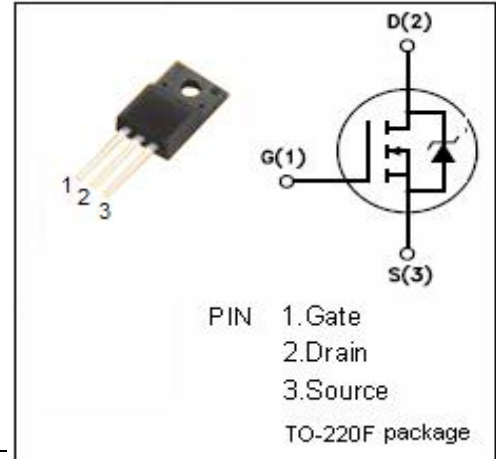

isc N-Channel MOSFET Transistor

9N50

• ELECTRICAL CHARACTERISTICS ($T_C=25^\circ\text{C}$)

SYMBOL	PARAMETER	CONDITIONS	MIN	TYPE	MAX	UNIT
$V_{(BR)DSS}$	Drain-Source Breakdown Voltage	$V_{GS}=0; I_D=250\mu\text{A}$	500			V
$V_{GS(th)}$	Gate Threshold Voltage	$V_{DS}=V_{GS}; I_D=250\mu\text{A}$	2.0		4.0	V
V_{SD}	Diode Forward On-Voltage	$I_S=9\text{A}; V_{GS}=0$			1.4	V
$R_{DS(on)}$	Drain-Source On-Resistance	$V_{GS}=10\text{V}; I_D=4.5\text{A}$			0.85	Ω
I_{GSS}	Gate-Body Leakage Current	$V_{GS}=\pm 20\text{V}; V_{DS}=0$			± 100	nA
I_{DSS}	Zero Gate Voltage Drain Current	$V_{DS}=500\text{V}; V_{GS}=0$			1	μA
C_{iss}	Input Capacitance	$V_{DS}=25\text{V};$		790		pF
C_{rss}	Reverse Transfer Capacitance	$V_{GS}=0\text{V};$		24		
C_{oss}	Output Capacitance	$f_T=1\text{MHz}$		130		
t_r	Rise Time	$V_{GS}=10\text{V};$			140	ns
$t_{d(on)}$	Turn-on Delay Time	$I_D=9\text{A};$			45	
t_f	Fall Time	$V_{DD}=250\text{V};$			125	
$t_{d(off)}$	Turn-off Delay Time	$R_L=25\Omega$			195	