

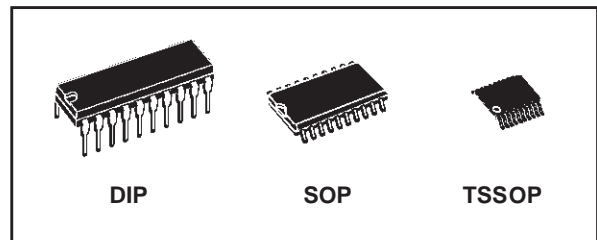

M74HC356

8 CHANNEL MULTIPLEXER/REGISTER WITH LATCHES (3 STATE)

- HIGH SPEED:
 $t_{PD} = 25 \text{ ns}$ (TYP.) at $V_{CC} = 6V$
- LOW POWER DISSIPATION:
 $I_{CC} = 4\mu A$ (MAX.) at $T_A = 25^\circ C$
- HIGH NOISE IMMUNITY:
 $V_{NIH} = V_{NIL} = 28\% V_{CC}$ (MIN.)
- SYMMETRICAL OUTPUT IMPEDANCE:
 $|I_{OH}| = I_{OL} = 6mA$ (MIN)
- BALANCED PROPAGATION DELAYS:
 $t_{PLH} \approx t_{PHL}$
- WIDE OPERATING VOLTAGE RANGE:
 V_{CC} (OPR) = 2V to 6V
- PIN AND FUNCTION COMPATIBLE WITH
 74 SERIES 356



ORDER CODES

PACKAGE	TUBE	T & R
DIP	M74HC356B1R	
SOP	M74HC356M1R	M74HC356RM13TR
TSSOP		M74HC356TTR

DESCRIPTION

The M74HC356 is an high speed CMOS 8 CHANNEL MULTIPLEXER/REGISTER (3-STATE) fabricated with silicon gate C²MOS technology.

This device contains an 8 channel digital multiplexer with an 8-input data register and a 3-bit address input register with 3-state outputs. The one of eight input data will be provided on the Y output pin (non-inverted output) and W output pin (inverted output) determined by the address data. The information at the data inputs (D0 to D7) is stored in the 8-bit flip-flop at the positive going edge of clock input (CLOCK). The

information at the address inputs (S0 to S2) is stored in the 3-bit latch at the negative pulse on \overline{SC} input. These outputs are disabled to be high-impedance when input $\overline{G1}$ is held high, input $\overline{G2}$ is held high or input $\overline{G3}$ is held low. This device is suitable for interfacing with bus lines in a bus organized system.

The M74HC356 is similar in function to the M74HC354, which has an 8-bit latch as the data register instead of an 8-bit flip-flop.

All inputs are equipped with protection circuits against static discharge and transient excess voltage.

PIN CONNECTION AND IEC LOGIC SYMBOLS

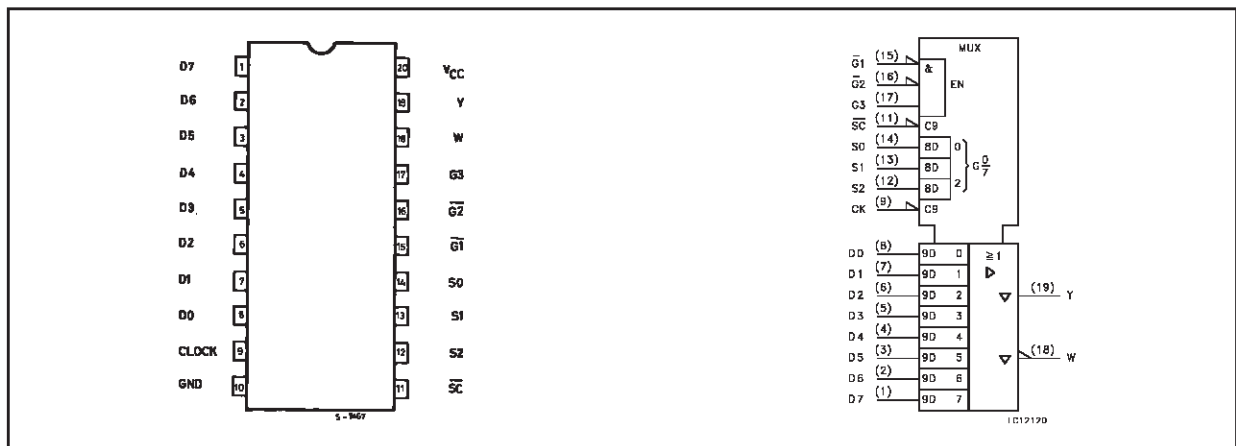

INPUT AND OUTPUT EQUIVALENT CIRCUIT

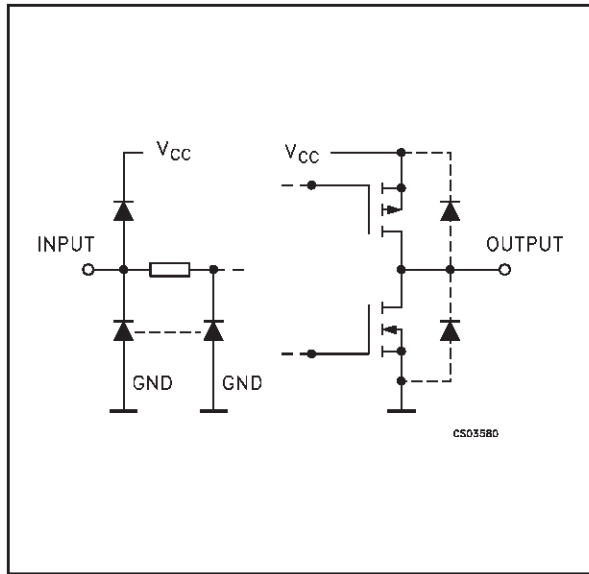

PIN DESCRIPTION

PIN No	SYMBOL	NAME AND FUNCTION
8, 7, 6, 5, 4, 3, 2, 1	D0 to D7	Data Inputs
9	CLOCK	Clock Input (LOW to HIGH, Edge-triggered)
11	SC	Latch Enable Input (Active LOW)
14, 13, 12	S0, S1, S2	Select Inputs
15, 16	G1, G2	Output Enable Inputs (Active LOW)
17	G3	Output Enable Input (Active HIGH)
18	W	3 - state Multiplexer Output (Active LOW)
19	Y	3 - state Multiplexer Output (Active HIGH)
10	GND	Ground (0V)
20	V _{CC}	Positive Supply Voltage

TRUTH TABLE

INPUTS							OUTPUTS	
SELECT *			CLOCK	OUTPUT ENABLES			W	Y
S2	S1	S0		G1	G2	G3		
X	X	X	X	H	X	X	Z	Z
X	X	X	X	X	H	X	Z	Z
X	X	X	X	X	X	L	Z	Z
L	L	L	┌	L	L	H	$\overline{D0}$	D0
L	L	L	└	L	L	H	$\overline{D0n}$	D0n
L	L	H	┌	L	L	H	$\overline{D1}$	D1
L	L	H	└	L	L	H	$\overline{D1n}$	D1n
L	H	L	┌	L	L	H	$\overline{D2}$	D2
L	H	L	└	L	L	H	$\overline{D2n}$	D2n
L	H	H	┌	L	L	H	$\overline{D3}$	D3
L	H	H	└	L	L	H	$\overline{D3n}$	D3n
H	L	L	┌	L	L	H	$\overline{D4}$	D4
H	L	L	└	L	L	H	$\overline{D4n}$	D4n
H	L	H	┌	L	L	H	$\overline{D5}$	D5
H	L	H	└	L	L	H	$\overline{D5n}$	D5n
H	H	L	┌	L	L	H	$\overline{D6}$	D6
H	H	L	└	L	L	H	$\overline{D6n}$	D6n
H	H	H	┌	L	L	H	$\overline{D7}$	D7
H	H	H	└	L	L	H	$\overline{D7n}$	D7n

X : Don't Care
 Z : High Impedance
 * : This Column Shows the Input Address Setup with SC low.
 D0n....D7n : The level of steady state inputs at input D1 through D7, respectively, before the most recent low to high transition of data control





TRUTH TABLE OF INTERNAL LATCH

INPUTS		OUTPUTS	
D	ST	Q	\overline{Q}
L	H	L	H
H	H	H	L
X	L	Qn	\overline{Qn}

X : Don't Care
 Qn : Data Stored at the trailing edge of the most recent ST pulse.

TRUTH TABLE OF INTERNAL LATCH (FLIP FLOP)

D	CK	Q
L		L
H		H
X		Qn

X : Don't Care
 Qn : No Change.

LOGIC DIAGRAM

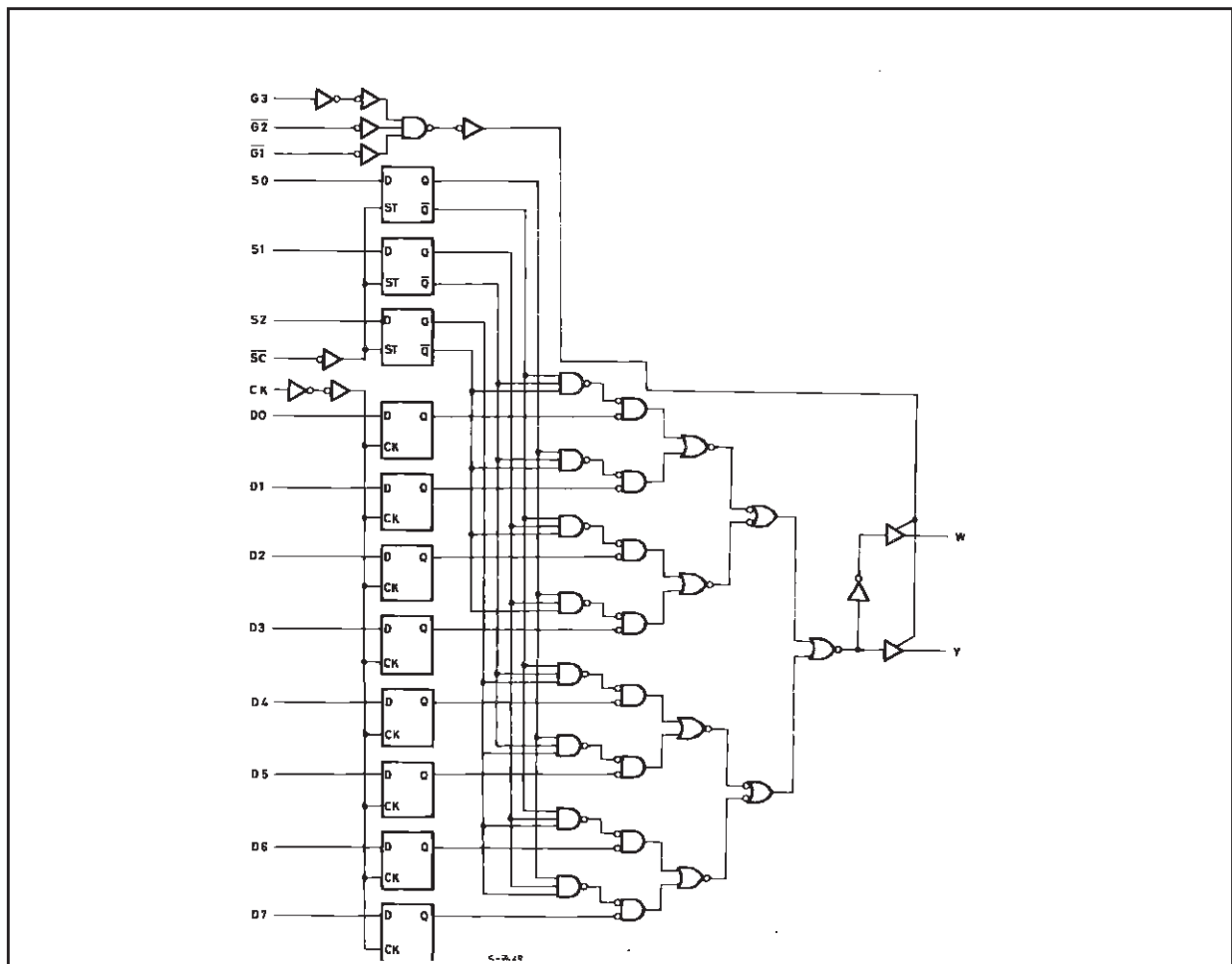

ABSOLUTE MAXIMUM RATINGS

Symbol	Parameter	Value	Unit
V_{CC}	Supply Voltage	-0.5 to +7	V
V_I	DC Input Voltage	-0.5 to $V_{CC} + 0.5$	V
V_O	DC Output Voltage	-0.5 to $V_{CC} + 0.5$	V
I_{IK}	DC Input Diode Current	± 20	mA
I_{OK}	DC Output Diode Current	± 20	mA
I_O	DC Output Current	± 35	mA
I_{CC} or I_{GND}	DC V_{CC} or Ground Current	± 70	mA
P_D	Power Dissipation	500(*)	mW
T_{stg}	Storage Temperature	-65 to +150	°C
T_L	Lead Temperature (10 sec)	300	°C

Absolute Maximum Ratings are those values beyond which damage to the device may occur. Functional operation under these conditions is not implied

(*) 500mW at 65 °C; derate to 300mW by 10mW/°C from 65°C to 85°C

RECOMMENDED OPERATING CONDITIONS

Symbol	Parameter	Value	Unit	
V_{CC}	Supply Voltage	2 to 6	V	
V_I	Input Voltage	0 to V_{CC}	V	
V_O	Output Voltage	0 to V_{CC}	V	
T_{op}	Operating Temperature	-55 to 125	°C	
t_r, t_f	Input Rise and Fall Time	$V_{CC} = 2.0V$	0 to 1000	ns
		$V_{CC} = 4.5V$	0 to 500	ns
		$V_{CC} = 6.0V$	0 to 400	ns

DC SPECIFICATIONS

Symbol	Parameter	Test Condition		Value						Unit	
		V _{CC} (V)		T _A = 25°C			-40 to 85°C		-55 to 125°C		
				Min.	Typ.	Max.	Min.	Max.	Min.		Max.
V _{IH}	High Level Input Voltage	2.0		1.5			1.5		1.5		V
		4.5		3.15			3.15		3.15		
		6.0		4.2			4.2		4.2		
V _{IL}	Low Level Input Voltage	2.0				0.5		0.5		0.5	V
		4.5				1.35		1.35		1.35	
		6.0				1.8		1.8		1.8	
V _{OH}	High Level Output Voltage	2.0	I _O =-20 μA	1.9	2.0		1.9		1.9		V
		4.5	I _O =-20 μA	4.4	4.5		4.4		4.4		
		6.0	I _O =-20 μA	5.9	6.0		5.9		5.9		
		4.5	I _O =-6.0 mA	4.18	4.31		4.13		4.10		
		6.0	I _O =-7.8 mA	5.68	5.8		5.63		5.60		
V _{OL}	Low Level Output Voltage	2.0	I _O =20 μA		0.0	0.1		0.1		0.1	V
		4.5	I _O =20 μA		0.0	0.1		0.1		0.1	
		6.0	I _O =20 μA		0.0	0.1		0.1		0.1	
		4.5	I _O =6.0 mA		0.17	0.26		0.33		0.40	
		6.0	I _O =7.8 mA		0.18	0.26		0.33		0.40	
I _I	Input Leakage Current	6.0	V _I = V _{CC} or GND			± 0.1		± 1		± 1	μA
I _{OZ}	High Impedance Output Leakage Current	6.0	V _I = V _{IH} or V _{IL} V _O = V _{CC} or GND			± 0.5		± 5		± 5	μA
I _{CC}	Quiescent Supply Current	6.0	V _I = V _{CC} or GND			4		40		80	μA

AC ELECTRICAL CHARACTERISTICS ($C_L = 50 \text{ pF}$, Input $t_r = t_f = 6 \text{ ns}$)

Symbol	Parameter	Test Condition			Value						Unit	
		V_{CC} (V)			$T_A = 25^\circ\text{C}$			$-40 \text{ to } 85^\circ\text{C}$		$-55 \text{ to } 125^\circ\text{C}$		
					Min.	Typ.	Max.	Min.	Max.	Min.		Max.
t_{TLH} t_{THL}	Output Transition Time	2.0	50			25	60		75		90	ns
		4.5				7	12		15		18	
		6.0				6	10		13		15	
t_{PLH} t_{PHL}	Propagation Delay Time (CLOCK - Y, W)	2.0	50			99	240		300		360	ns
		4.5				28	48		60		72	
		6.0				22	41		51		61	
		2.0	150			117	280		350		420	
		4.5				33	56		70		84	
		6.0				26	48		60		71	
t_{PLH} t_{PHL}	Propagation Delay Time (Sn - Y, W)	2.0	50			111	260		325		390	ns
		4.5				32	52		65		78	
		6.0				24	44		55		66	
		2.0	150			128	300		375		450	
		4.5				37	60		75		90	
		6.0				28	51		64		77	
t_{PLH} t_{PHL}	Propagation Delay Time (SC - Y, W)	2.0	50			115	270		340		405	ns
		4.5				33	54		68		81	
		6.0				25	46		58		69	
		2.0	150			132	310		390		465	
		4.5				38	62		78		93	
		6.0				29	53		66		79	
t_{PZL} t_{PZH}	High Impedance Output Enable Time	2.0	50	$R_L = 1\text{K}\Omega$		48	125		155		190	ns
		4.5				14	25		31		38	
		6.0				11	21		26		32	
		2.0	150	$R_L = 1\text{K}\Omega$		65	165		205		250	
		4.5				19	33		41		50	
		6.0				15	28		35		43	
t_{PLZ} t_{PHZ}	High Impedance Output Disable Time	2.0	50	$R_L = 1\text{K}\Omega$		43	155		195		235	ns
		4.5				18	31		39		47	
		6.0				16	26		33		40	
f_{MAX}	Maximum Clock Frequency	2.0	50		6.2	20		5		4.2		MHz
		4.5			31	80		25		21		
		6.0			37	82		30		25		
$t_{W(L)}$ $t_{W(H)}$	Minimum Pulse Width (CLOCK)	2.0	50			25	75		95		110	ns
		4.5				6	15		19		22	
		6.0				6	13		16		19	
$t_{W(L)}$	Minimum Pulse Width (\overline{SC})	2.0	50			13	75		95		110	ns
		4.5				6	15		19		22	
		6.0				6	13		16		19	
t_S	Minimum Set-up Time (Dn to CLOCK)	2.0	50			21	50		65		75	ns
		4.5				4	10		13		15	
		6.0				3	9		11		13	
t_S	Minimum Set-up Time (Sn to CLOCK)	2.0	50			9	50		65		75	ns
		4.5				2	10		13		15	
		6.0				2	9		11		13	

Symbol	Parameter	Test Condition		Value				Unit			
		V _{CC} (V)		T _A = 25°C			-40 to 85°C		-55 to 125°C		
				Min.	Typ.	Max.	Min.		Max.	Min.	Max.
t _H	Minimum Hold Time (Dn,Sn to CLOCK)	2.0	50			5		5		5	ns
		4.5				5		5		5	
		6.0				5		5		5	

CAPACITIVE CHARACTERISTICS

Symbol	Parameter	Test Condition		Value				Unit			
		V _{CC} (V)		T _A = 25°C			-40 to 85°C		-55 to 125°C		
				Min.	Typ.	Max.	Min.		Max.	Min.	Max.
C _{IN}	Input Capacitance	5.0			5	10		10		10	pF
C _{PD}	Power Dissipation Capacitance (note 1)	5.0			59						pF

1) C_{PD} is defined as the value of the IC's internal equivalent capacitance which is calculated from the operating current consumption without load. (Refer to Test Circuit). Average operating current can be obtained by the following equation. $I_{CC(opr)} = C_{PD} \times V_{CC} \times f_{IN} + I_{CC}$

TEST CIRCUIT

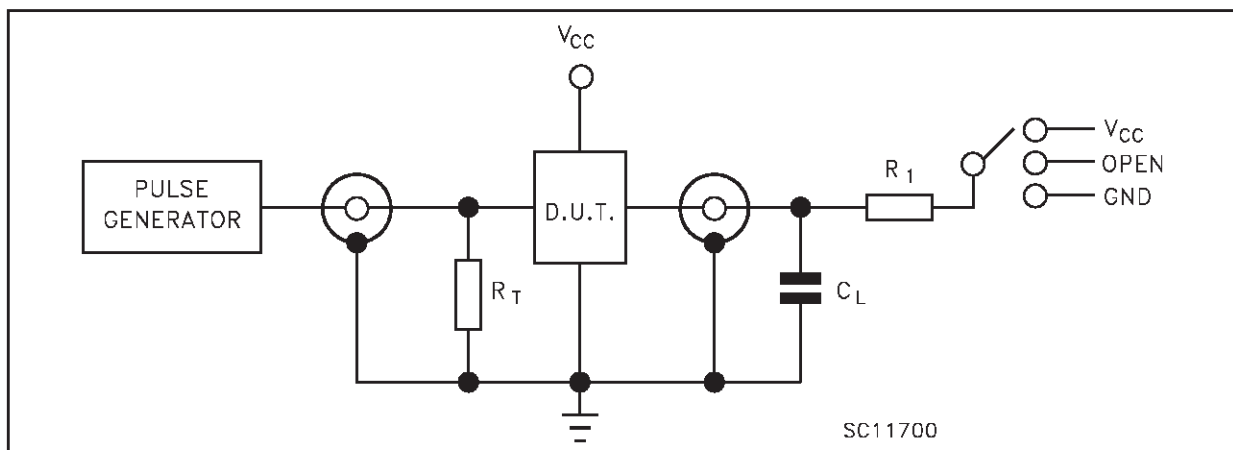

TEST	SWITCH
t _{PLH} , t _{PHL}	Open
t _{PZL} , t _{PLZ}	V _{CC}
t _{PZH} , t _{PHZ}	GND

C_L = 50pF/150pF or equivalent (includes jig and probe capacitance)

R₁ = 1KΩ or equivalent

R_T = Z_{OUT} of pulse generator (typically 50Ω)

WAVEFORM 1 : PROPAGATION DELAY TIMES (f=1MHz; 50% duty cycle)

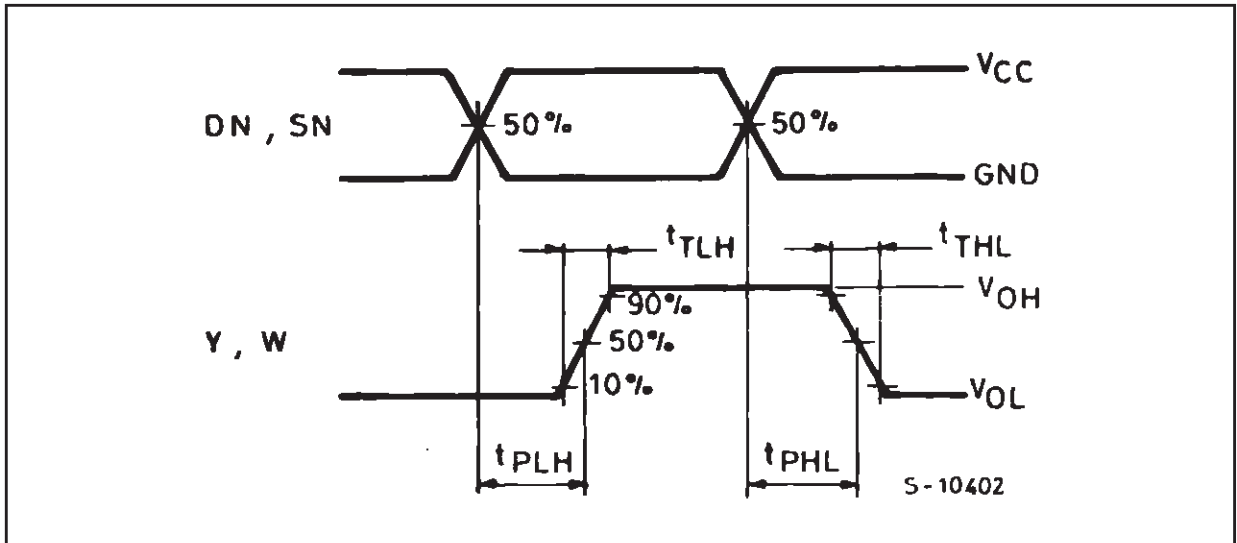

WAVEFORM 2 : SETUP AND HOLD TIMES (f=1MHz; 50% duty cycle)

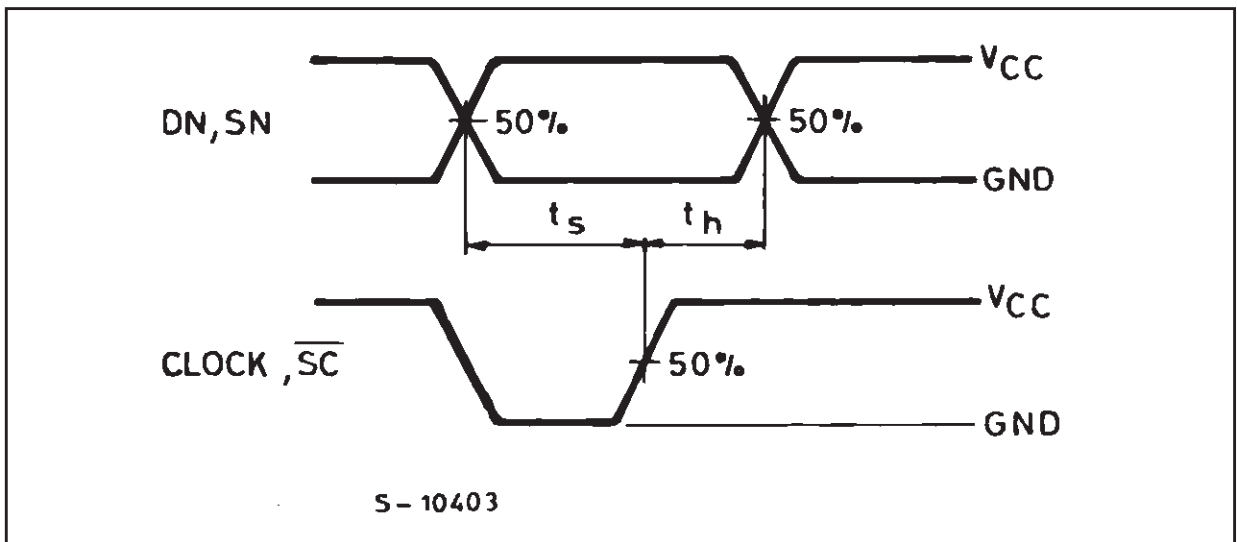

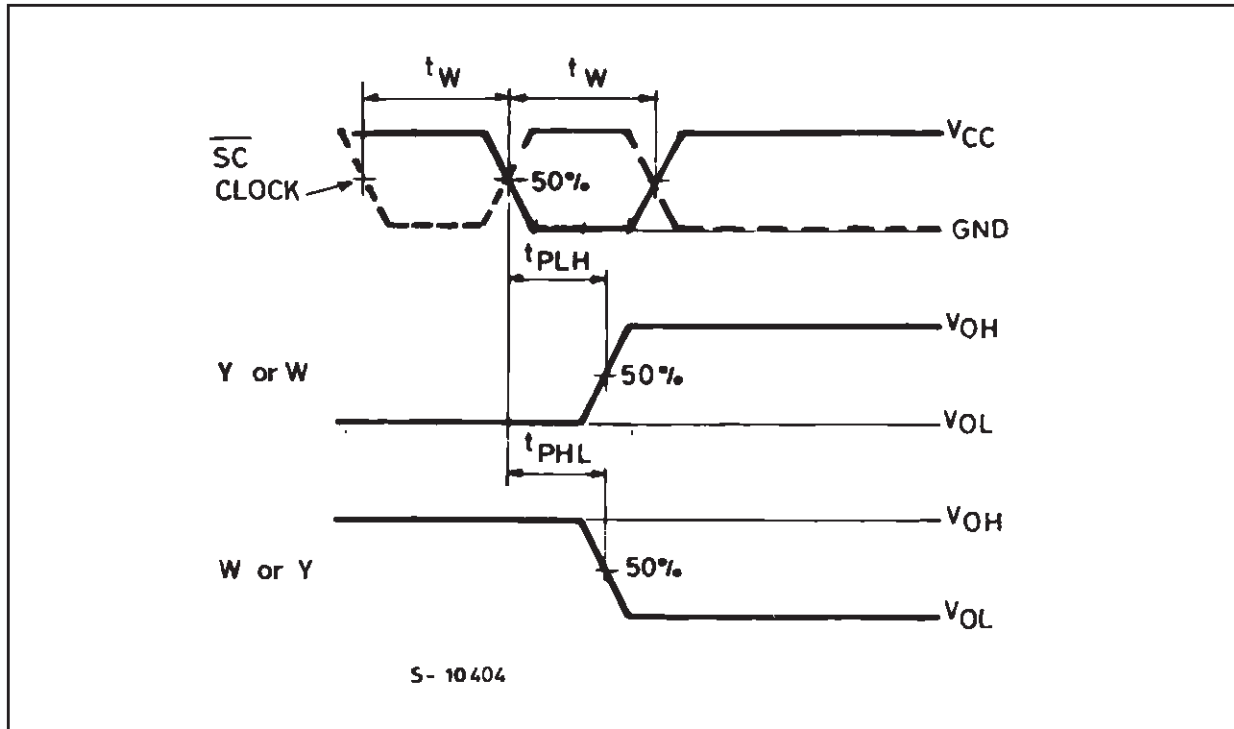
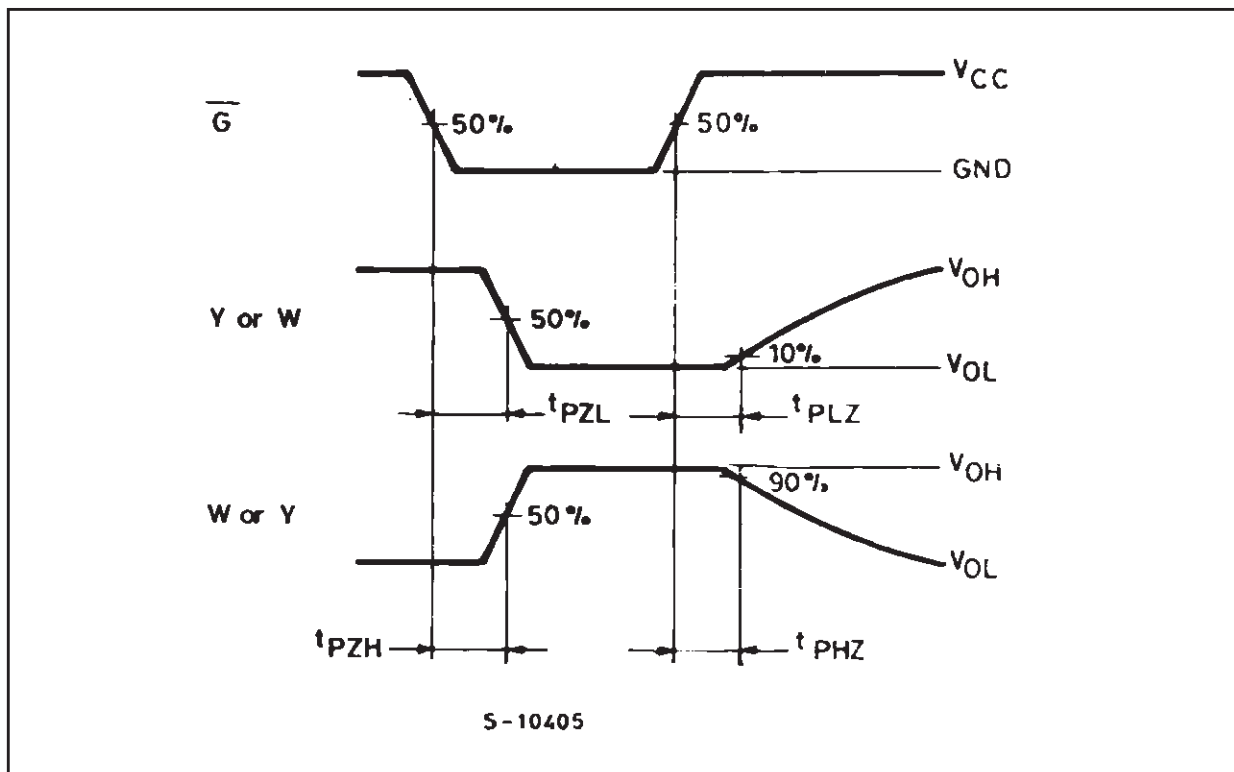
WAVEFORM 3 : PROPAGATION DELAY TIMES, MINIMUM PULSE WIDTH ($f=1\text{MHz}$; 50% duty cycle)WAVEFORM 4 : OUTPUT ENABLE AND DISABLE TIME ($f=1\text{MHz}$; 50% duty cycle)

Plastic DIP-20 (0.25) MECHANICAL DATA

DIM.	mm.			inch		
	MIN.	TYP.	MAX.	MIN.	TYP.	MAX.
a1	0.254			0.010		
B	1.39		1.65	0.055		0.065
b		0.45			0.018	
b1		0.25			0.010	
D			25.4			1.000
E		8.5			0.335	
e		2.54			0.100	
e3		22.86			0.900	
F			7.1			0.280
I			3.93			0.155
L		3.3			0.130	
Z			1.34			0.053

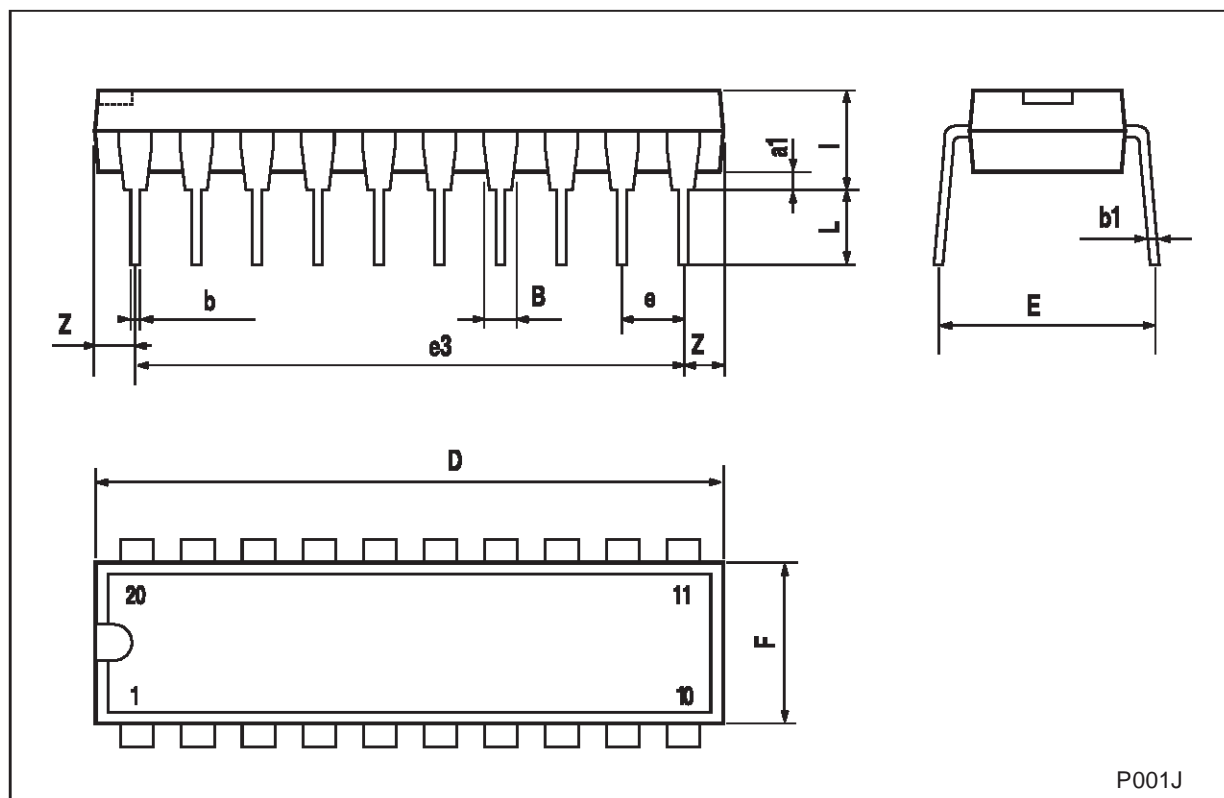

P001J

SO-20 MECHANICAL DATA

DIM.	mm.			inch		
	MIN.	TYP.	MAX.	MIN.	TYP.	MAX.
A			2.65			0.104
a1	0.1		0.2	0.004		0.008
a2			2.45			0.096
b	0.35		0.49	0.014		0.019
b1	0.23		0.32	0.009		0.012
C		0.5			0.020	
c1	45° (typ.)					
D	12.60		13.00	0.496		0.512
E	10.00		10.65	0.393		0.419
e		1.27			0.050	
e3		11.43			0.450	
F	7.40		7.60	0.291		0.300
L	0.50		1.27	0.020		0.050
M			0.75			0.029
S	8° (max.)					

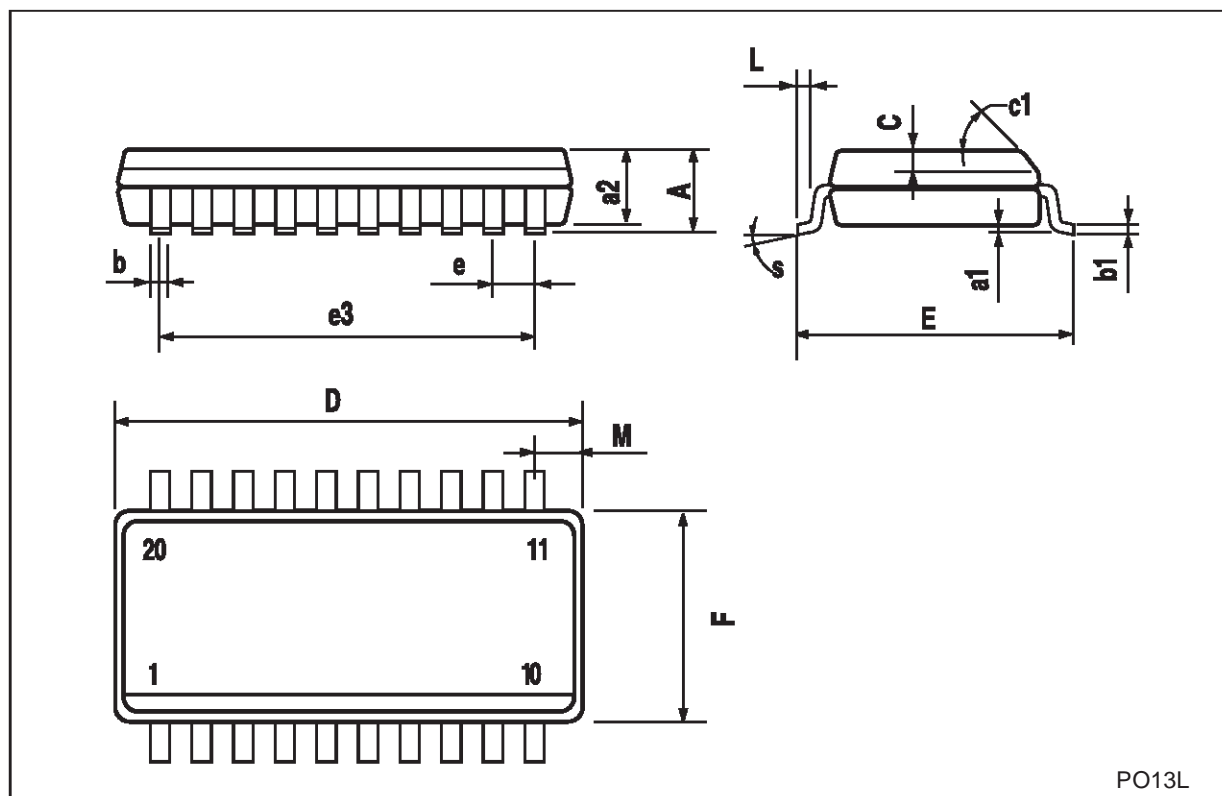

PO13L

TSSOP20 MECHANICAL DATA

DIM.	mm.			inch		
	MIN.	TYP	MAX.	MIN.	TYP.	MAX.
A			1.2			0.047
A1	0.05		0.15	0.002	0.004	0.006
A2	0.8	1	1.05	0.031	0.039	0.041
b	0.19		0.30	0.007		0.012
c	0.09		0.20	0.004		0.0089
D	6.4	6.5	6.6	0.252	0.256	0.260
E	6.2	6.4	6.6	0.244	0.252	0.260
E1	4.3	4.4	4.48	0.169	0.173	0.176
e		0.65 BSC			0.0256 BSC	
K	0°		8°	0°		8°
L	0.45	0.60	0.75	0.018	0.024	0.030

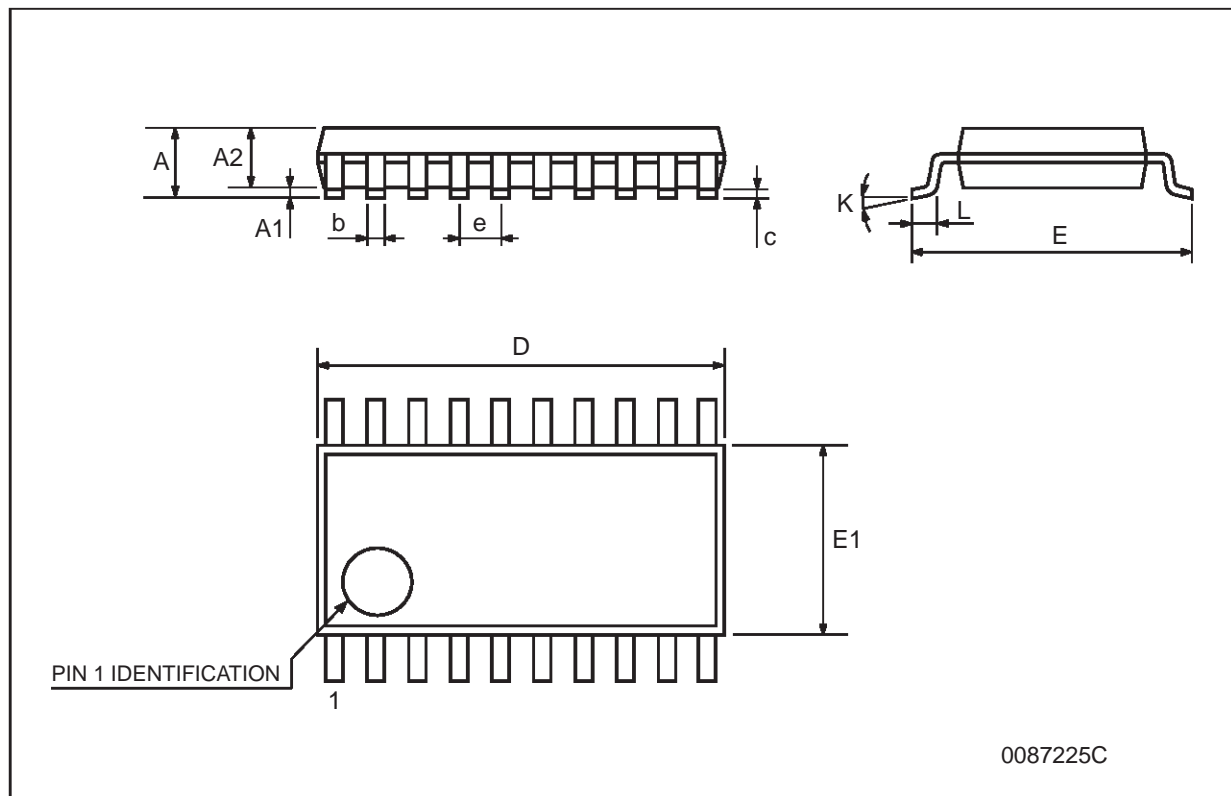

Information furnished is believed to be accurate and reliable. However, STMicroelectronics assumes no responsibility for the consequences of use of such information nor for any infringement of patents or other rights of third parties which may result from its use. No license is granted by implication or otherwise under any patent or patent rights of STMicroelectronics. Specifications mentioned in this publication are subject to change without notice. This publication supersedes and replaces all information previously supplied. STMicroelectronics products are not authorized for use as critical components in life support devices or systems without express written approval of STMicroelectronics.

© The ST logo is a registered trademark of STMicroelectronics

© 2001 STMicroelectronics - Printed in Italy - All Rights Reserved
STMicroelectronics GROUP OF COMPANIES

Australia - Brazil - China - Finland - France - Germany - Hong Kong - India - Italy - Japan - Malaysia - Malta - Morocco
Singapore - Spain - Sweden - Switzerland - United Kingdom

© <http://www.st.com>

