

DETAILS

Product Number	CA14026_STRADA-SQ-ME
Family	Strada
Type	Assembly
Color	clear
Diameter	25 x 25 mm
Height	8,8 mm
Style	square
Optic Material	PMMA
Holder Material	
Fastening	tape, pin, screw
Status	production ready
ROHS Compliant	Yes
Date Updated	11/11/2015



OPTICAL PROPERTIES

LED	Viewing	Light	Efficiency	cd/lm	Connector
	Angle	Beam			
PSL440	Asymmetric deg	Streetligh...	91 %	0.710	-
PSL445	Asymmetric deg	Streetligh...	91 %	0.430	-
MK-R	asymmetric deg	Streetligh...	93 %	0.640	-
MHB-A/B	sim: Asymmetri	Streetligh...	-	-	-
XHP50	Asymmetric deg	Streetligh...	92 %	0.580	-
LUXEON M/MX	asymmetric deg	Streetligh...	92 %	0.670	-
LUXEON MZ	asymmetric deg	Streetligh...	93 %	0.960	-
LUXEON XR-M linear 1x3, 1x4, 1x5	Asymmetric deg	Streetligh...	93 %	0.670	-
NV4x144A	Asymmetric deg	Streetligh...	91 %	0.540	-
NVSxx19B/NVSxx19C	sim: Asymmetri	Streetligh...	sim: 92 %	sim: 0.980	-
Duris S10	Asymmetric deg	Streetligh...	90 %	0.510	-
Duris P10	sim: Asymmetri	Streetligh...	sim: 91 %	sim: 0.710	-

D

C

B

A

4

4

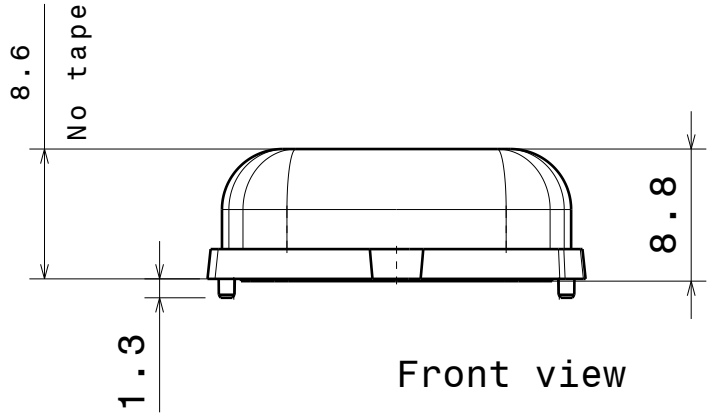

Front view

3

3

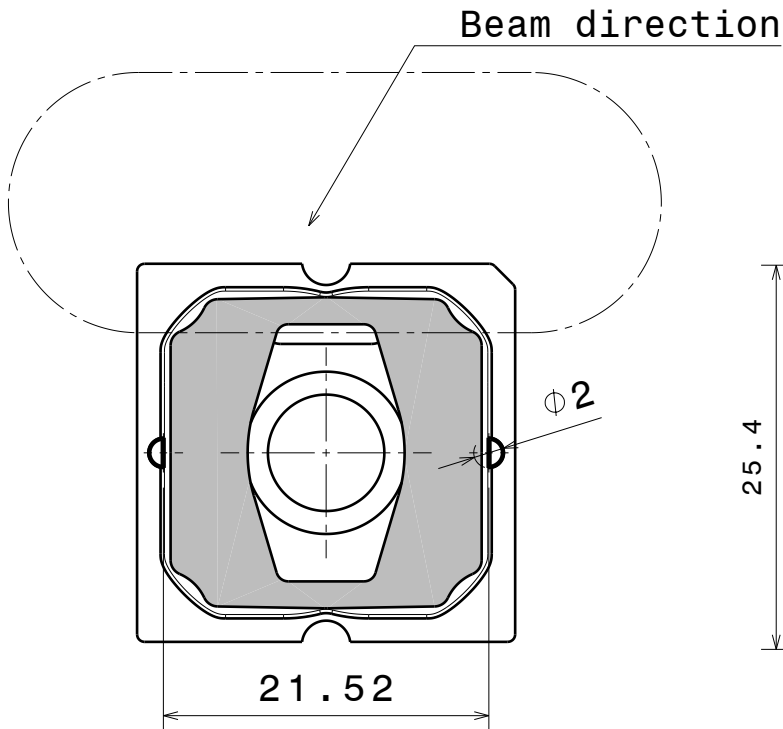

Bottom view

2

2

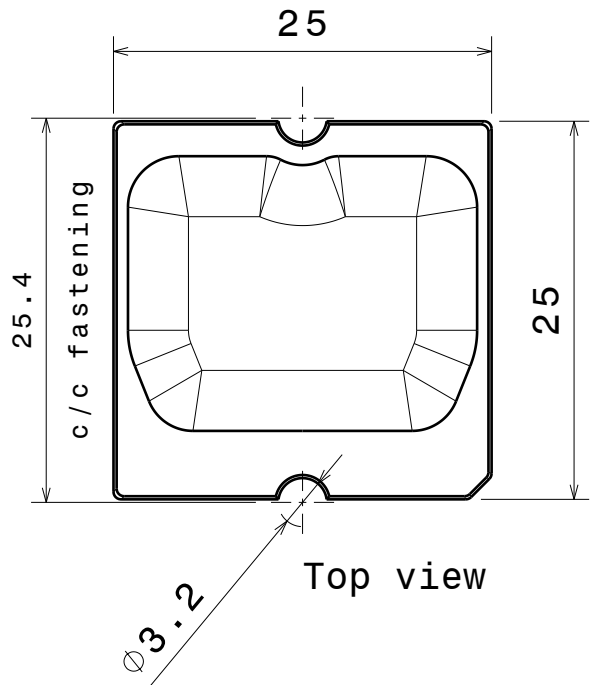

Top view

Tolerances if not otherwise shown
According to DIN ISO 2768-1
Linear measures:
Up to 30mm class M, otherwise class C.
According to DIN ISO 2768-2
Form and position: class L

LEDiL LediL Oy
Salorankatu 10
FIN 24240 SALO
Finland

THIRD ANGLE PROJECTION:

DRAWING TITLE
STRADA-SQ-ME_Mechanicaldrawing

This drawing is the property of LEDiL Oy. It may not be reproduced, copied or communicated without a written agreement with LEDiL Oy."

SIZE	PART NUMBER		
A4	-		
SCALE	2:1	WEIGHT	-
SHEET		1/1	

D

A

1

1

Luminaire: LEDiL Oy CA14026_STRADA-SQ-ME_(PSL440)
Lamps: 1 x Citizen_PSL440_256.951lm@250mA_P=2.8697W_I=0.250A

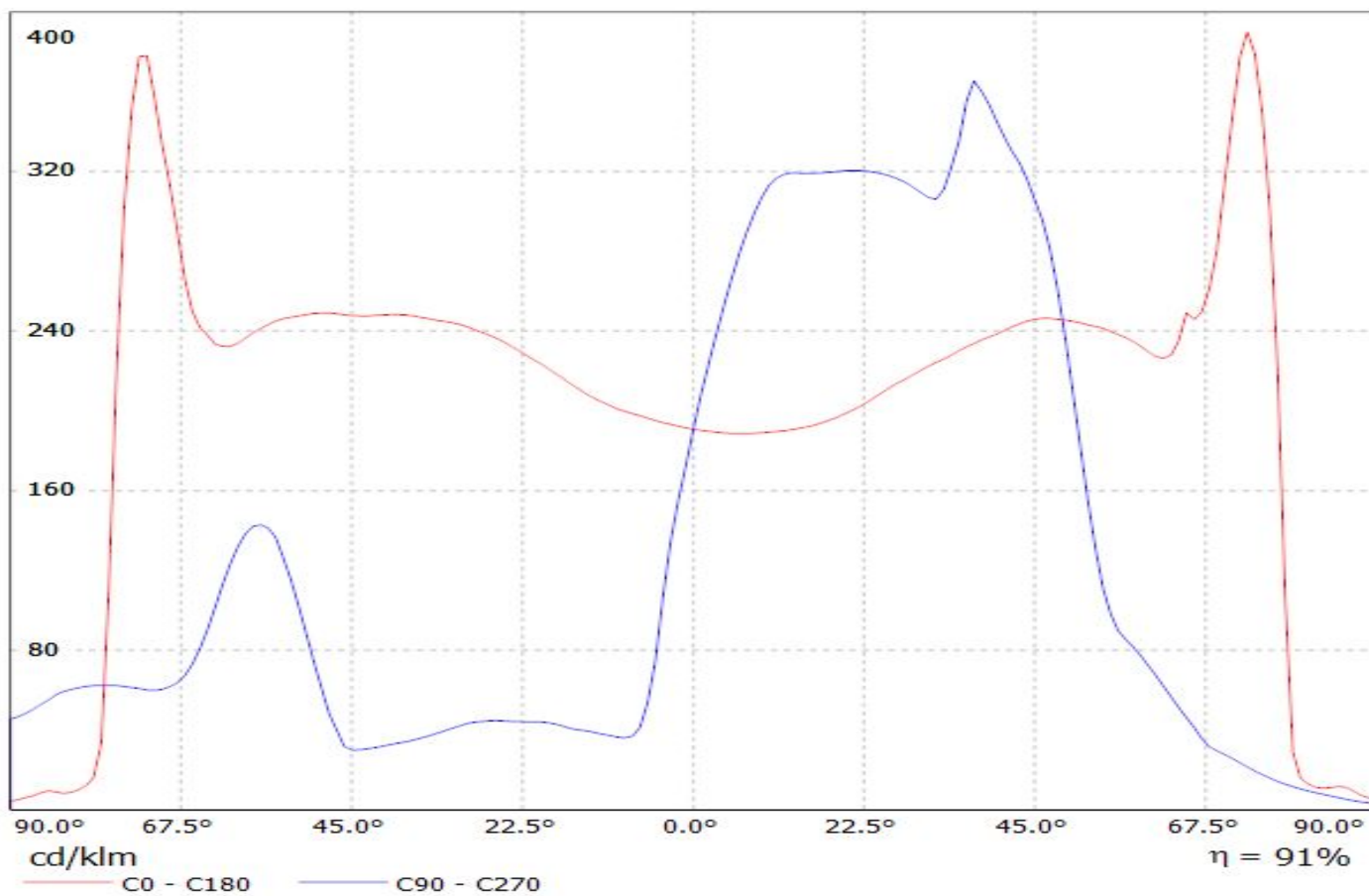

Luminaire: LEDiL Oy CA14026_STRADA-SQ-ME_(PSL445)
Lamps: 1 x Citizen_PSL445_424.116lm@250mA_P=2.81625W_I=0.250A_CCT=2700K

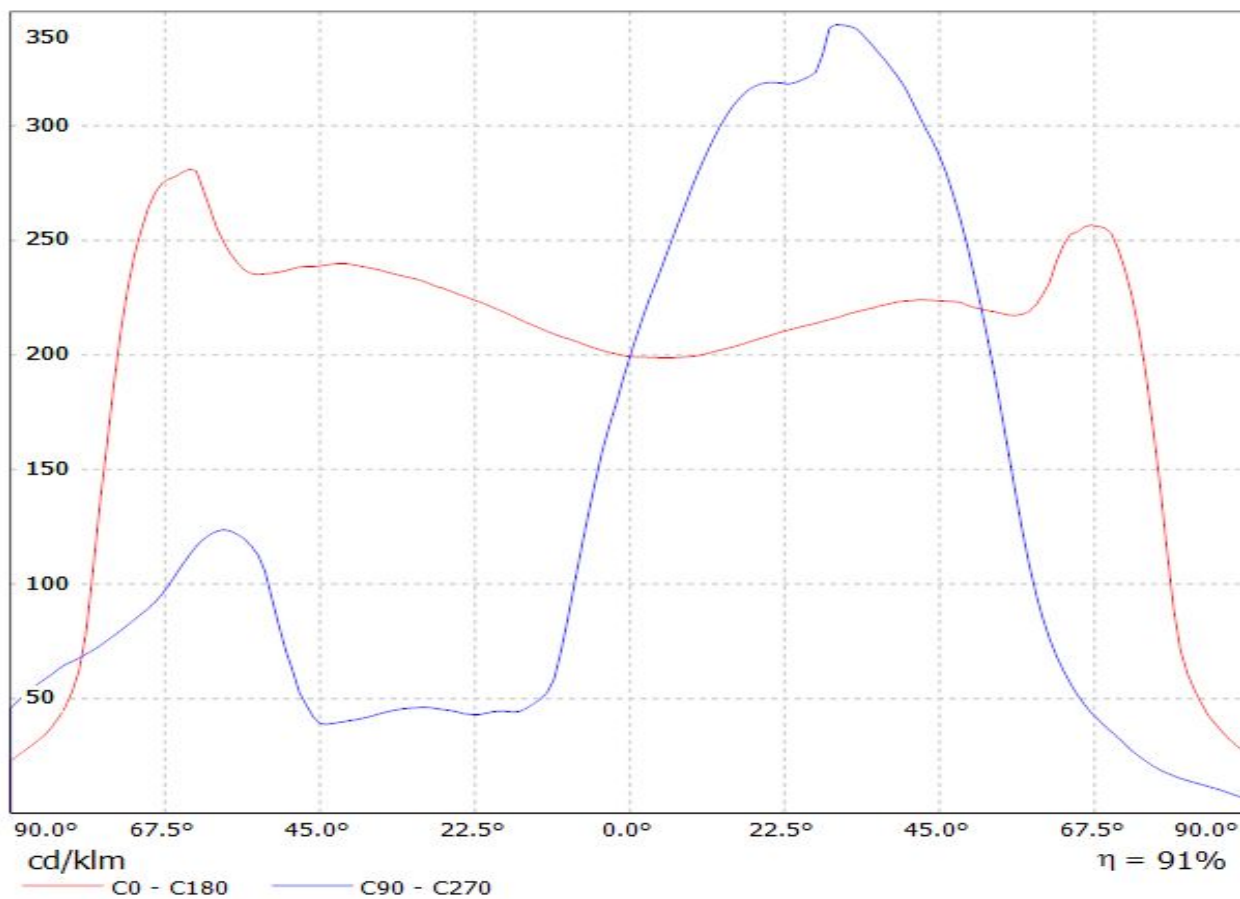

Luminaire: LEDiL Oy CA14026_STRADA-SQ-ME_(MK-R) Eff.93.4%
Lamps: 1 x CREE_MK-R_356.197lm@250mA_P=2.84186W_I=249.9mA

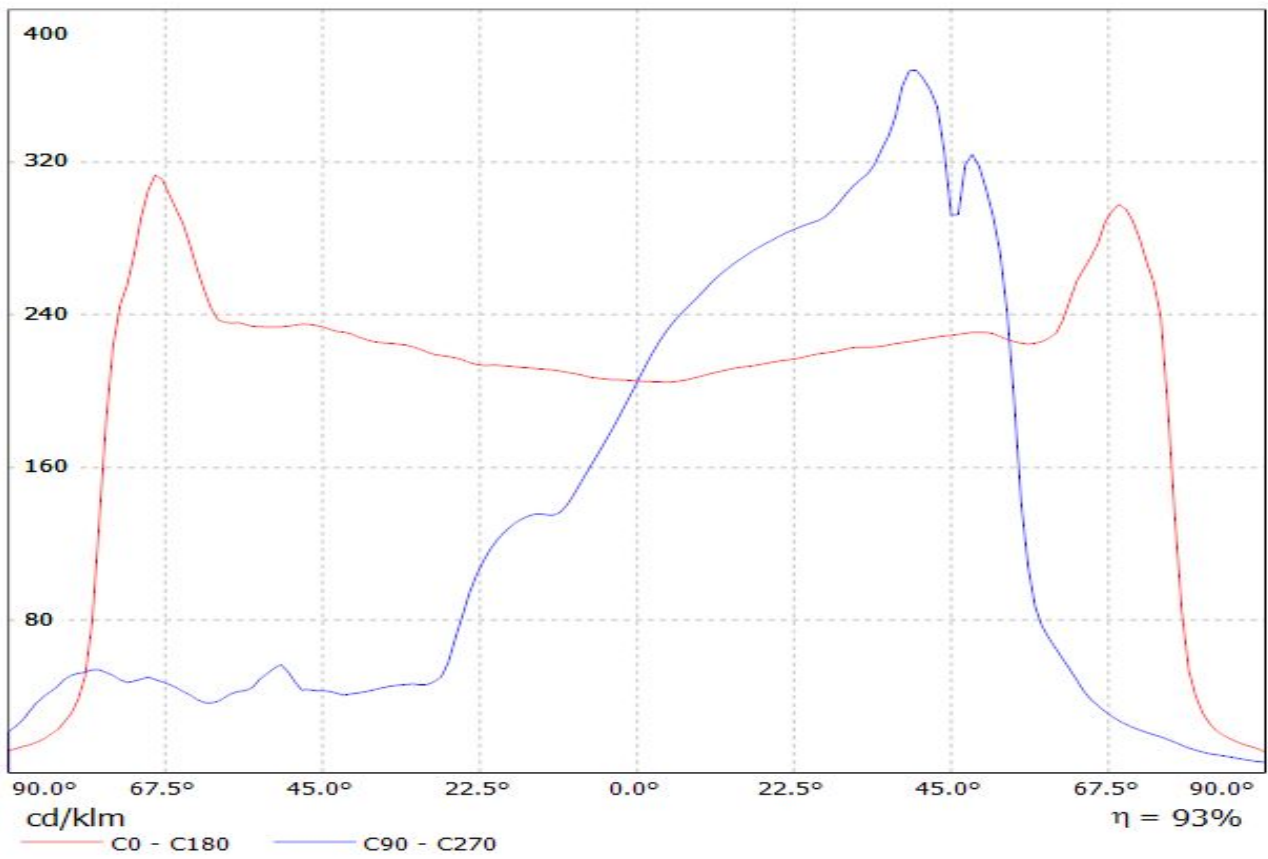

Luminaire: LEDiL Oy CA14026_STRADA-SQ-ME_(Cree_XHP50_cool_white)
Lamps: 1 x Cree_XHP50_cool_white_243.713lm@250mA_P=1.42945W_η=0.2499A

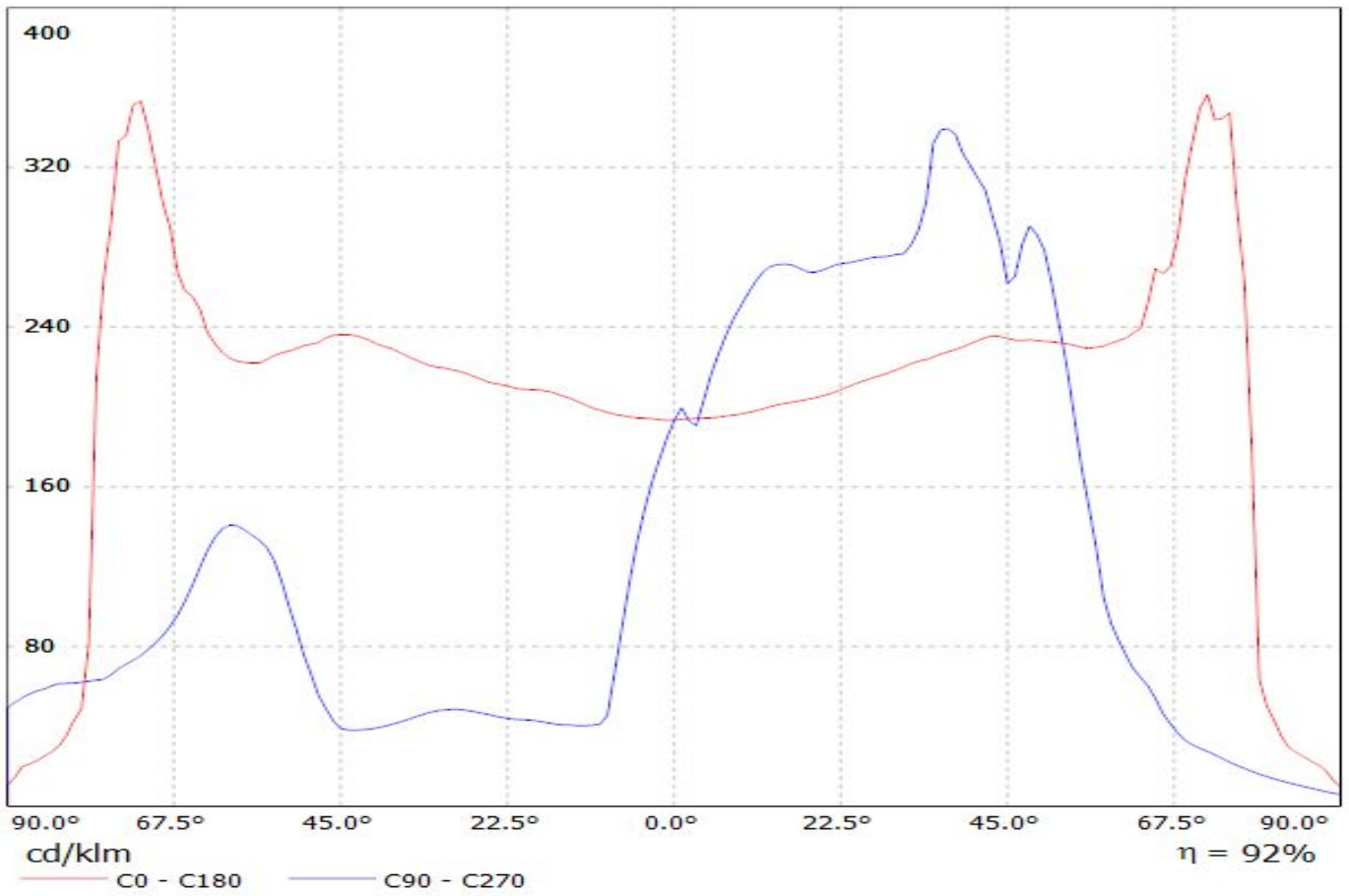

Luminaire: LEDiL Oy CA14026_STRADA-SQ-ME_(Luxeon_M)
Lamps: 1 x Luxeon M 347lm@250mA CCT:4000K P: 2.7W I:250mA

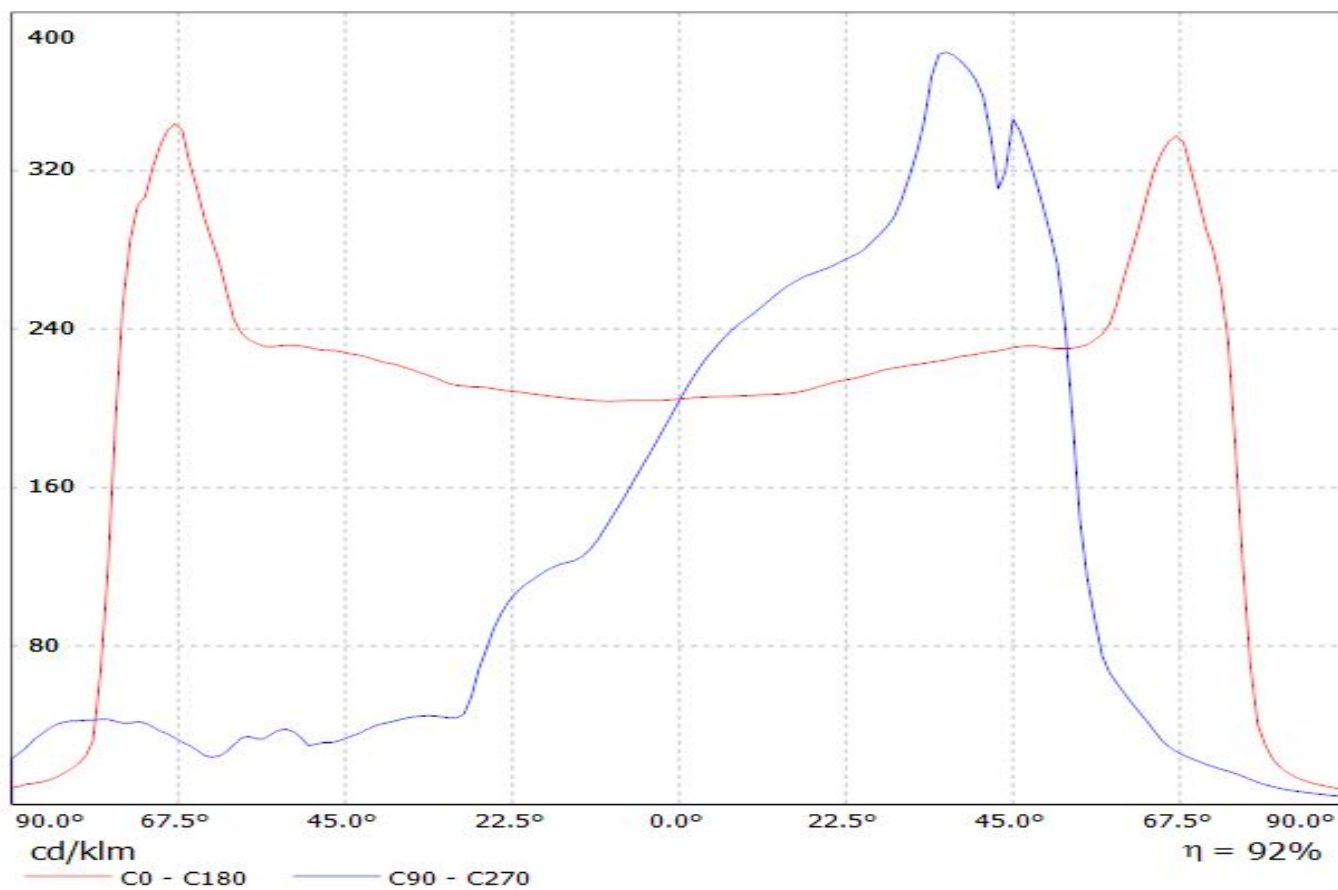

Luminaire: LEDiL Oy CA14026_STRADA-SQ-ME_(Luxeon_MZ) Eff: 93%
Lamps: 1 x LUXEON-MZ_263.073lm@250mA_P=2.7399W_I=249.9mA

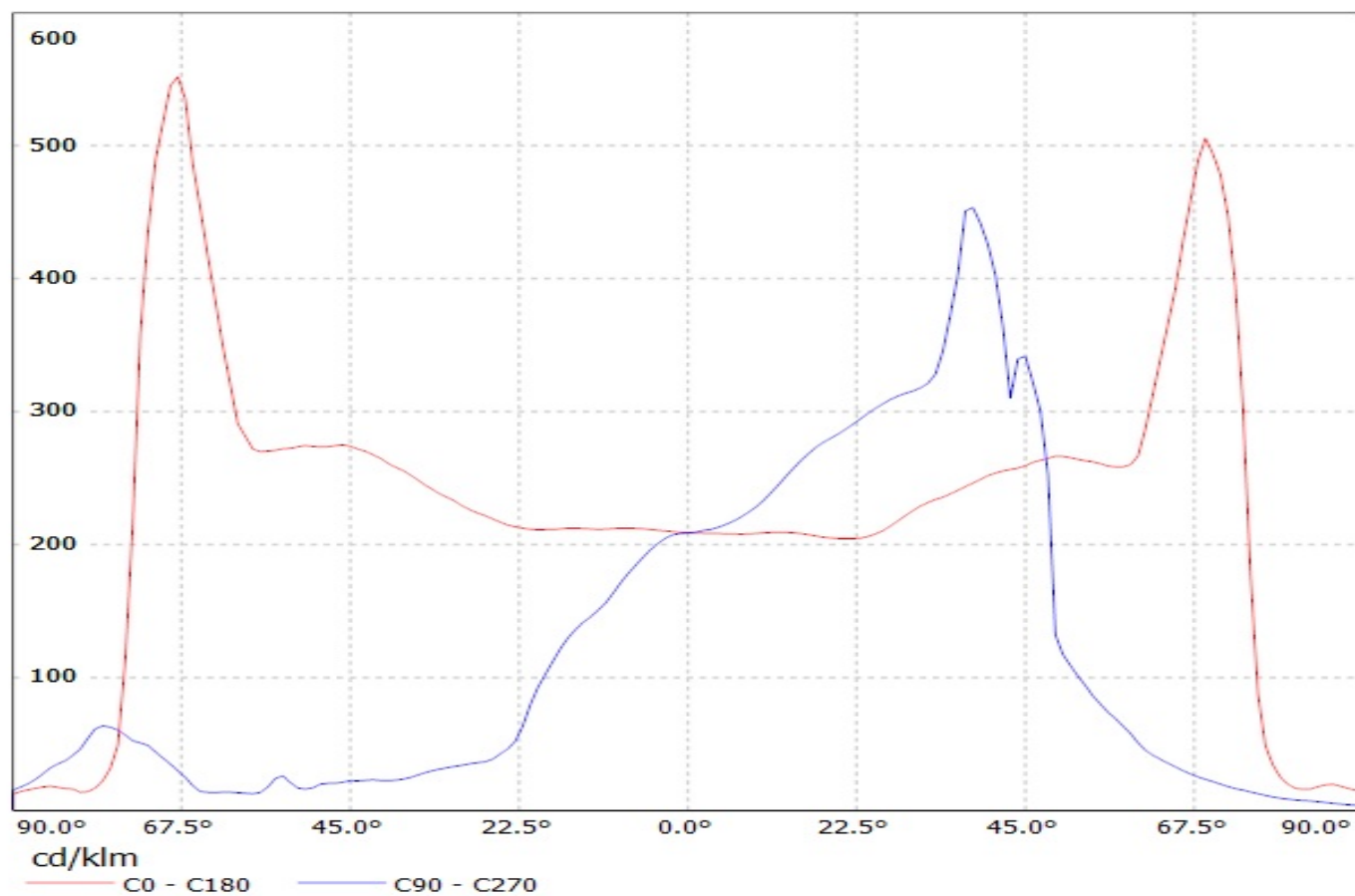

Luminaire: Ledil CA14026_STRADA-SQ-ME_(LUXEON_XR-M_Linear_1x4)
Lamps: 1 x Lumiled_LUXEON_XR-M_Linear_1x4_1798.32lm@250mA_P=11.005W_I=0.25A

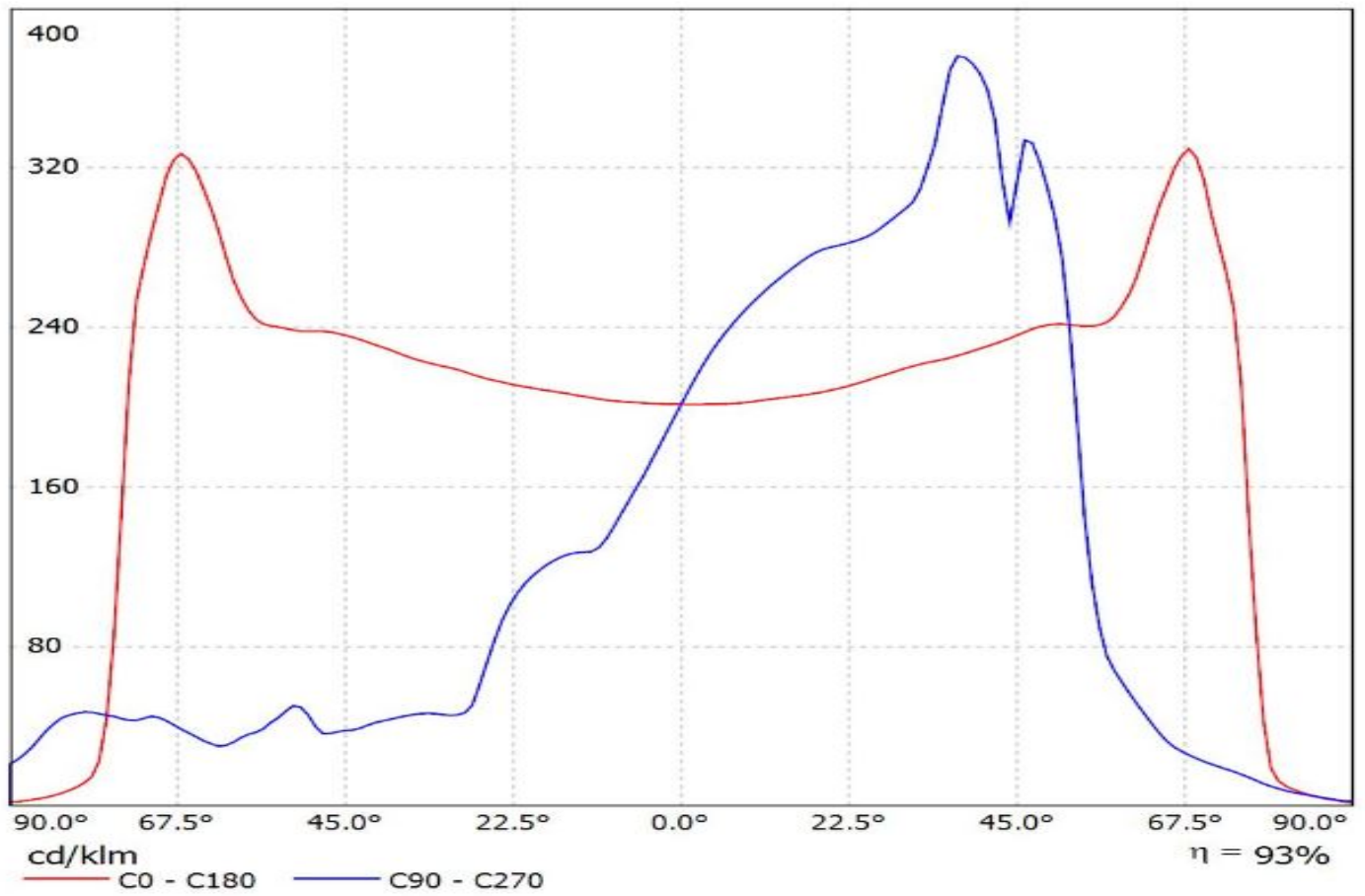

Luminaire: LEDiL Oy CA14026_STRADA-SQ-ME_(NV4x144A)
Lamps: 1 x Nichia_NV4x144A_477.901lm@250mA_P=2.8042W_I=0.250A

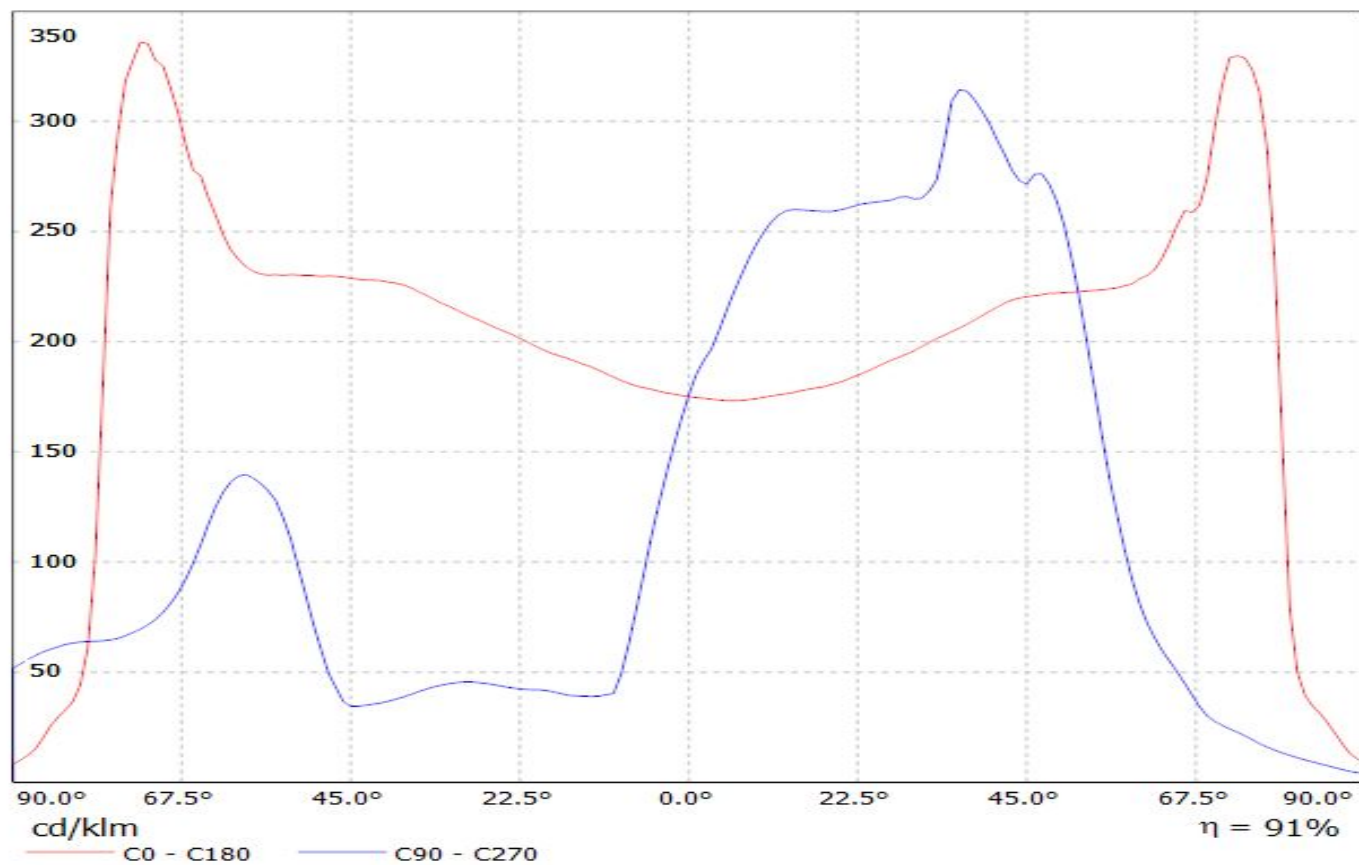

Luminaire: Ledil Oy CA14026_STRADA-SQ-ME_(NVSxx19C)_SIMULATED
Lamps: 1 x Nichia NVSW219C

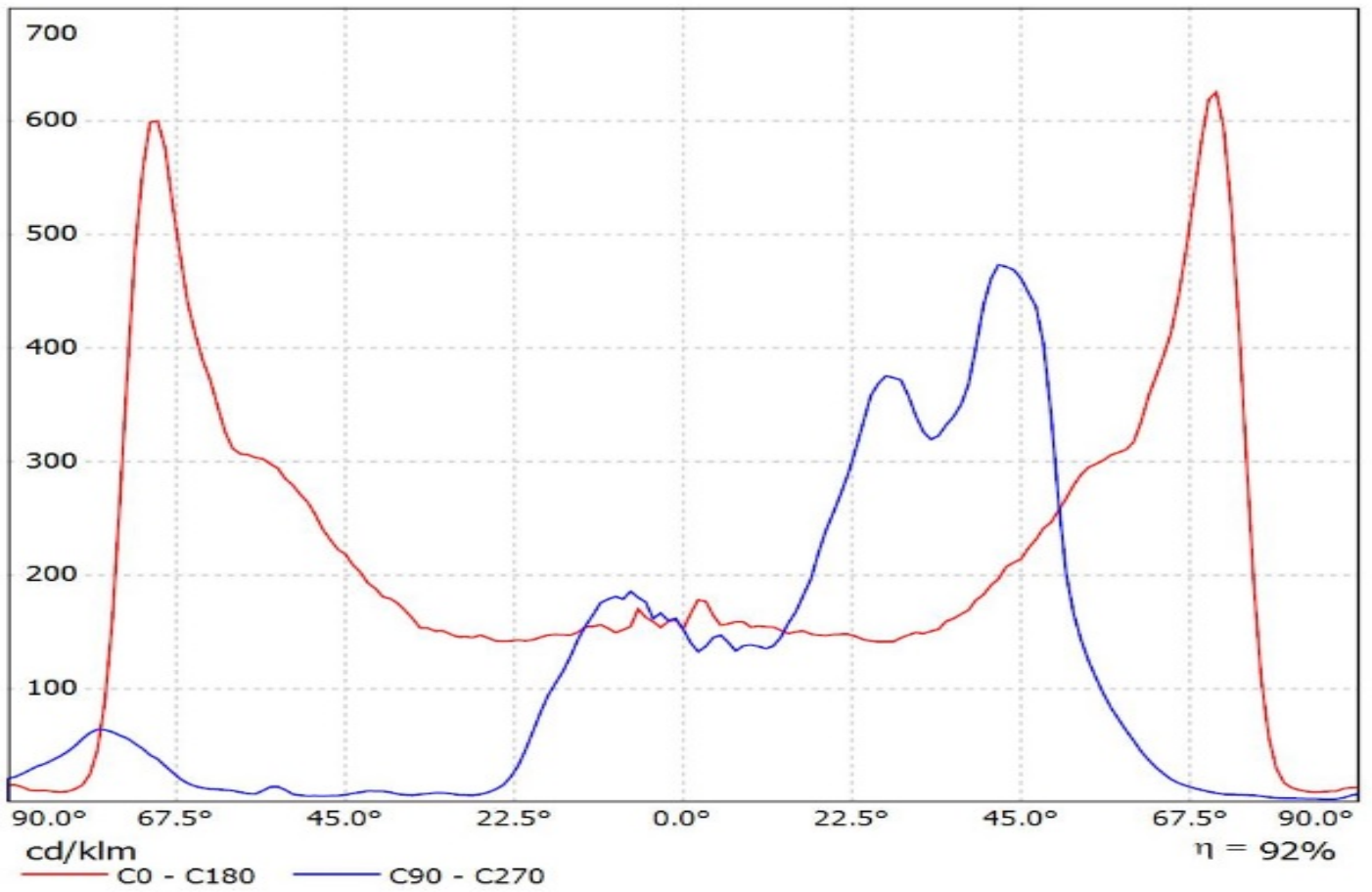

Luminaire: Ledil CA14026_STRADA-SQ-ME_(Duris_S10)

Lamps: 1 x Osram_Duris_S10_(GW-P7LP32.EM)_999.98lm@250mA_P=9.2345W_I=0.25A

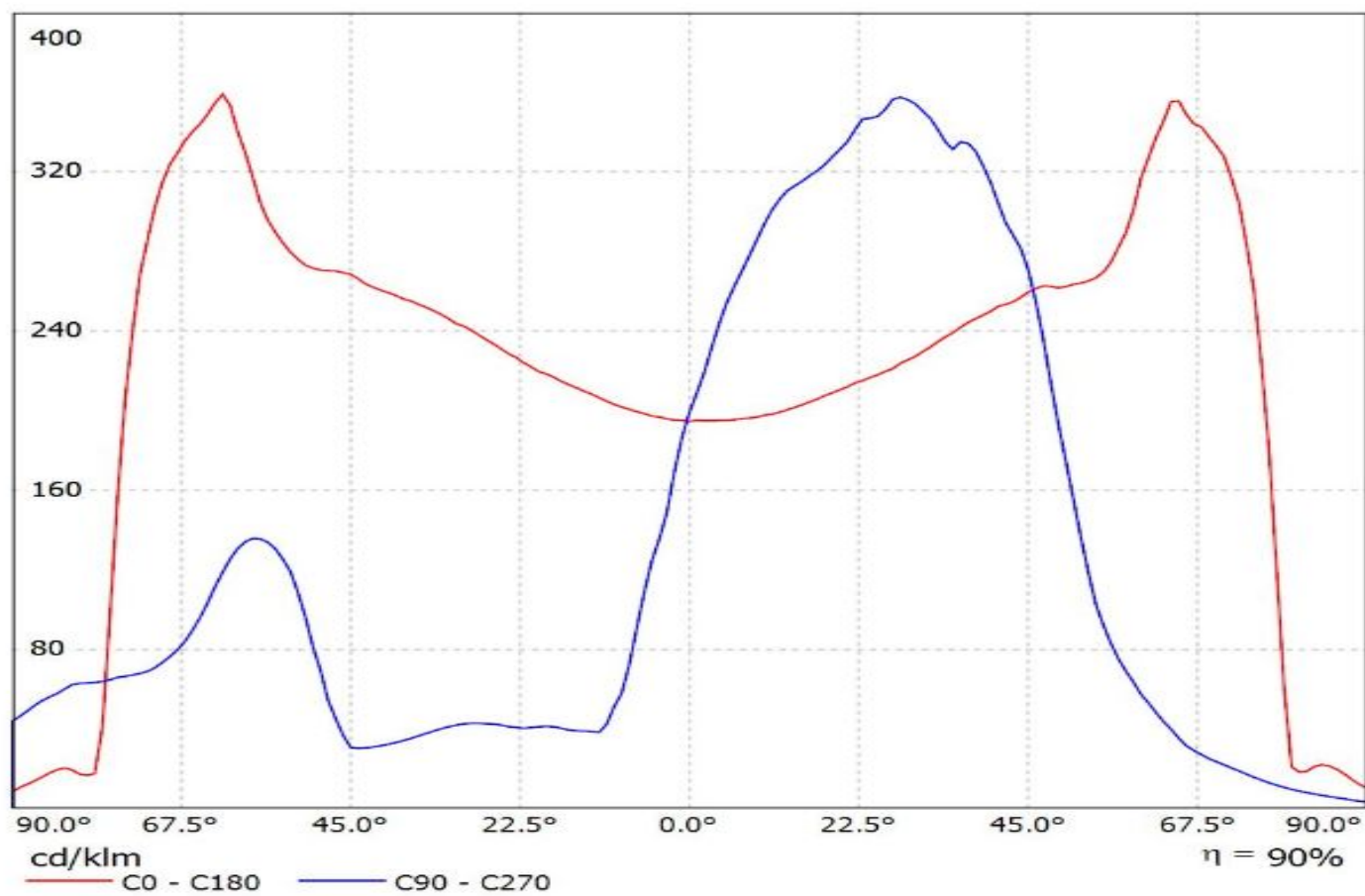

Luminaire: LEDiL Oy CA14026_STRADA-SQ-ME_(PSL440)
Lamps: 1 x Citizen_PSL440_256.951lm@250mA_P=2.8697W_I=0.250A

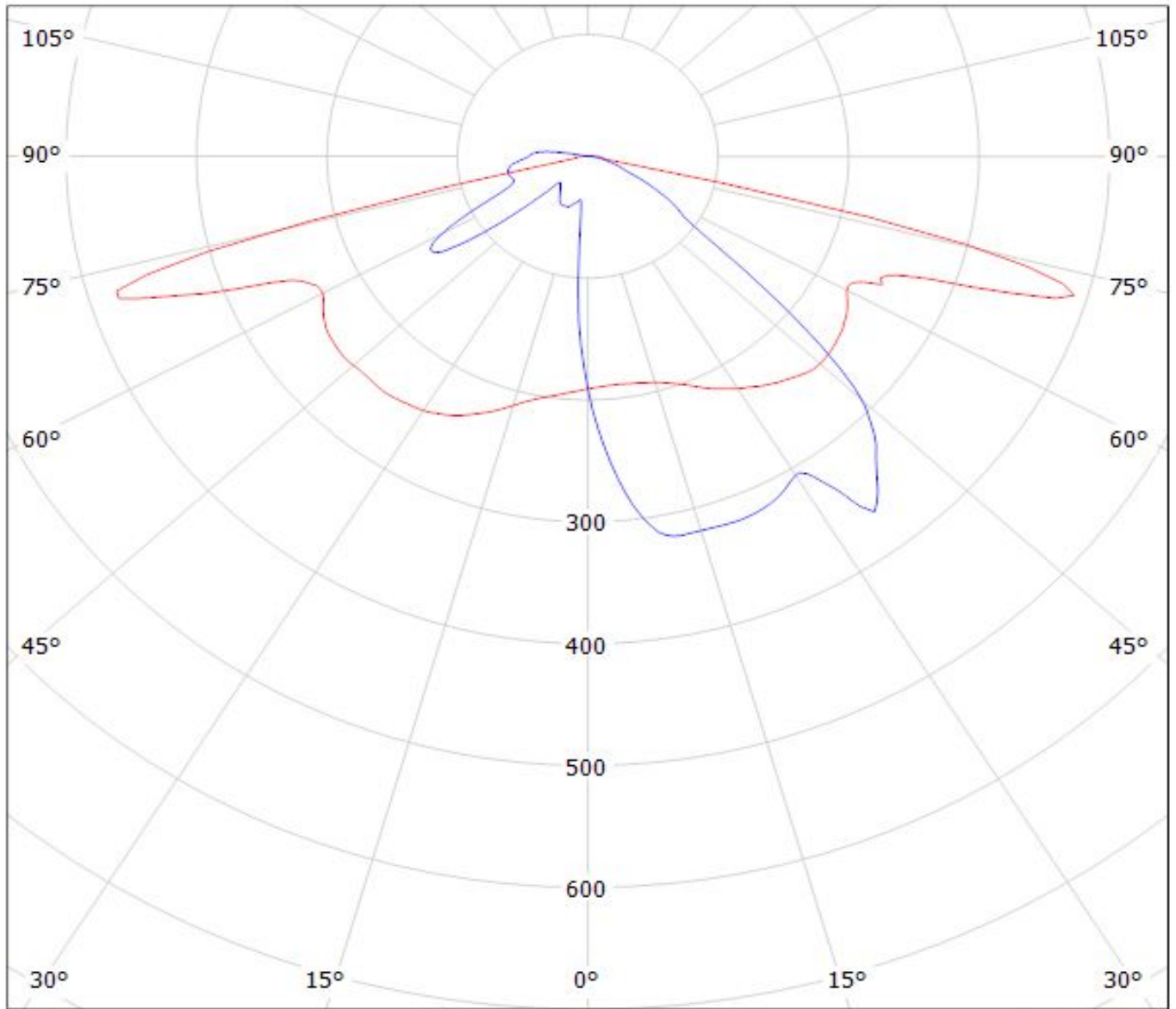

cd/klm

— C0 - C180

— C90 - C270

$\eta = 91\%$

Luminaire: LEDiL Oy CA14026_STRADA-SQ-ME_(PSL445)
Lamps: 1 x Citizen_PSL445_424.116lm@250mA_P=2.81625W_I=0.250A_CCT=2700K

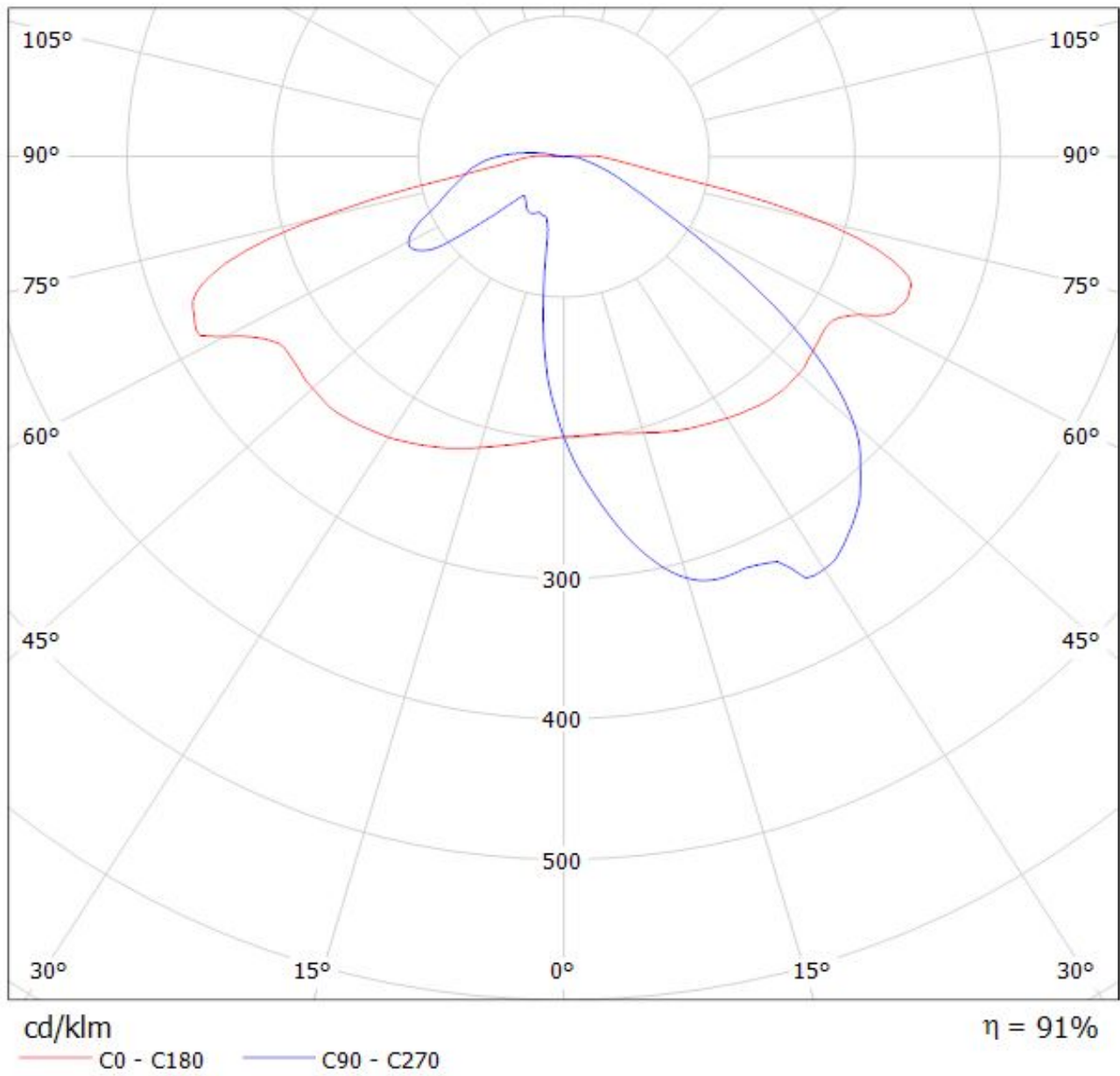

Luminaire: LEDiL Oy CA14026_STRADA-SQ-ME_(MK-R) Eff.93.4%
Lamps: 1 x CREE_MK-R_356.197lm@250mA_P=2.84186W_I=249.9mA

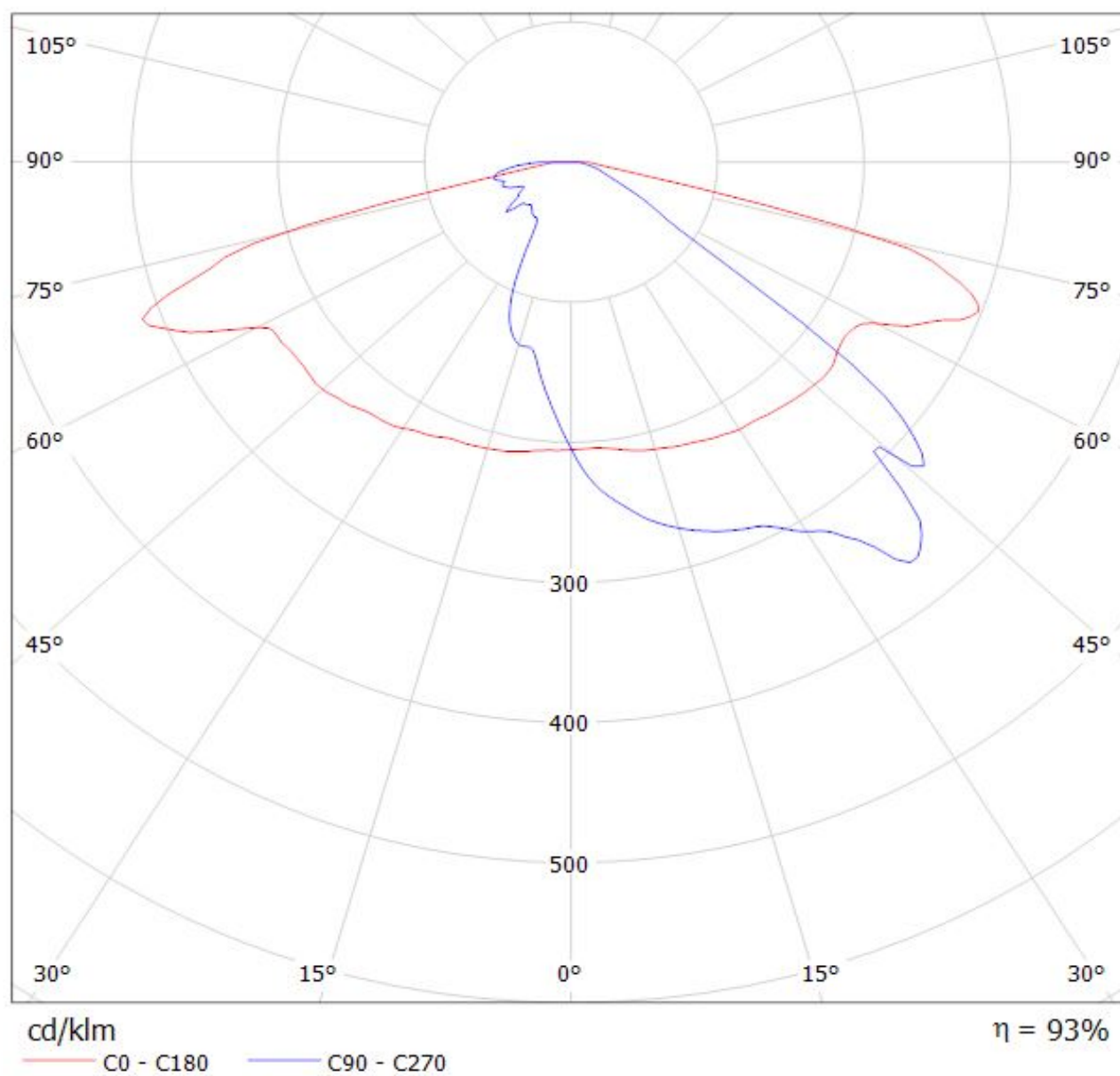

Luminaire: LEDiL Oy CA14026_STRADA-SQ-ME_(Cree_XHP50_cool_white)
Lamps: 1 x Cree_XHP50_cool_white_243.713lm@250mA_P=1.42945W_ι=0.2499A

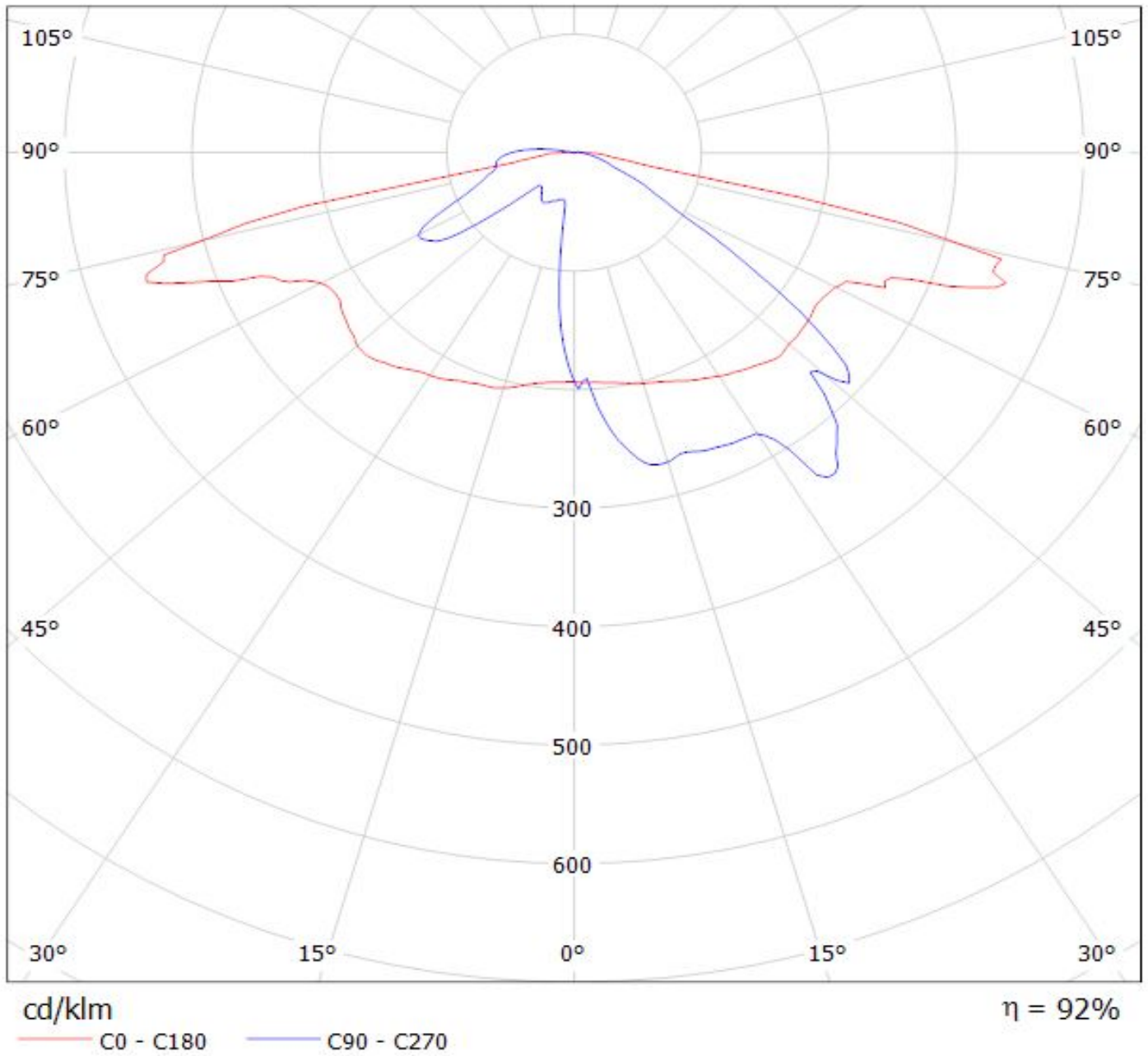

Luminaire: LEDiL Oy CA14026_STRADA-SQ-ME_(Luxeon_M)
Lamps: 1 x Luxeon M 347lm@250mA CCT:4000K P: 2.7W I:250mA

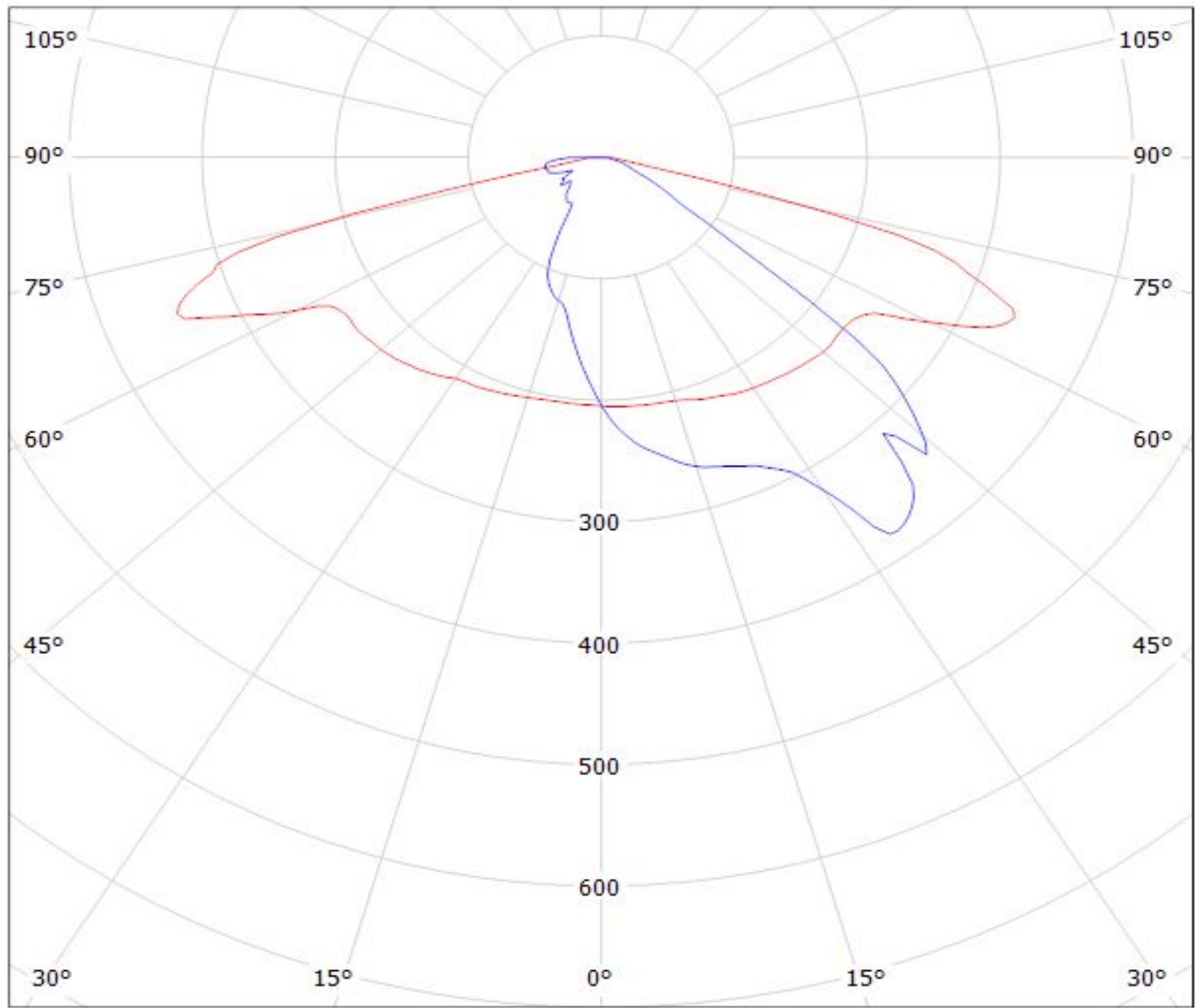

cd/klm
— C0 - C180 — C90 - C270

$\eta = 92\%$

Luminaire: LEDiL Oy CA14026_STRADA-SQ-ME_(Luxeon_MZ) Eff: 93%
Lamps: 1 x LUXEON-MZ_263.073lm@250mA_P=2.7399W_I=249.9mA

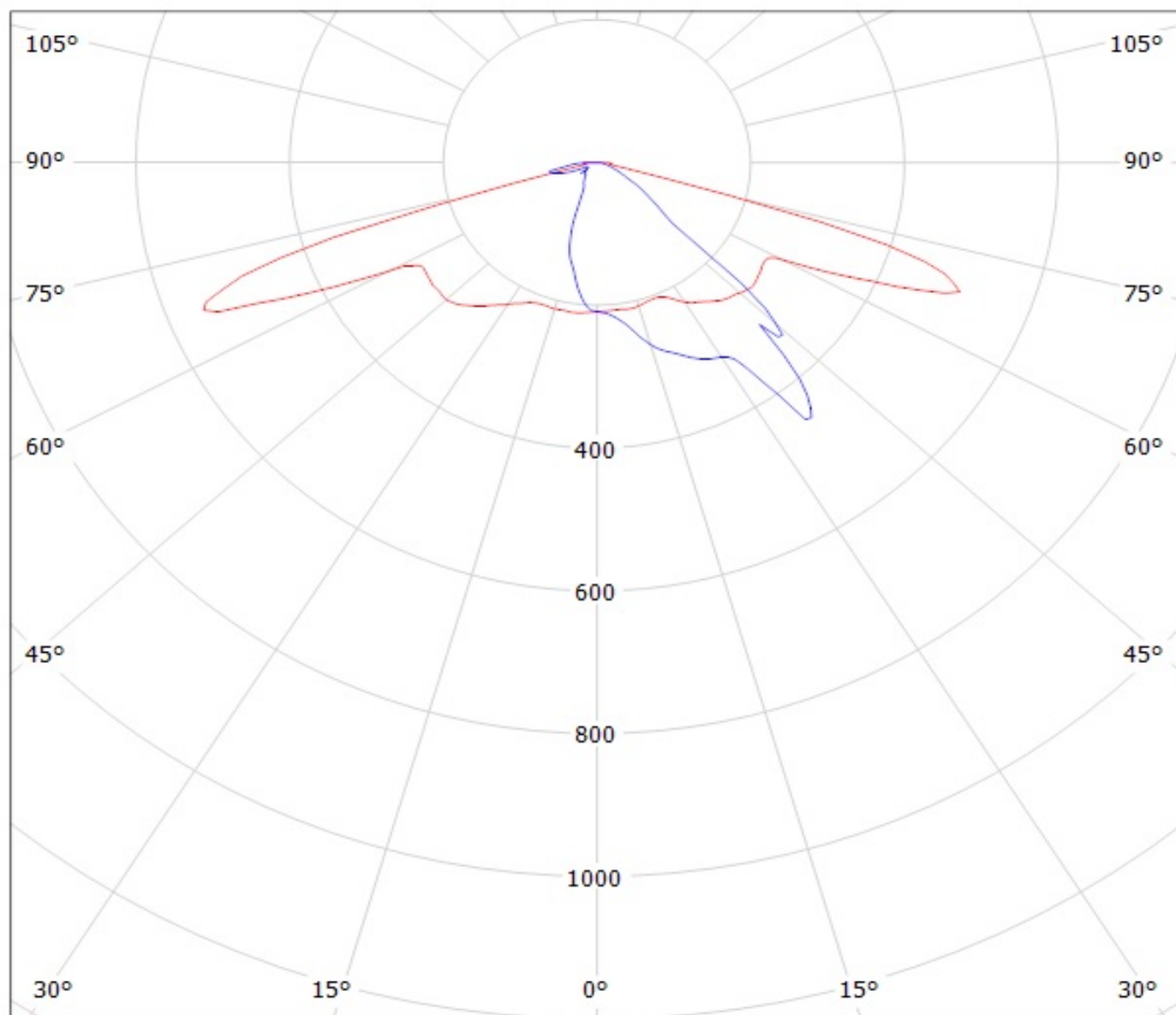

cd/klm

— C0 - C180 — C90 - C270

Luminaire: Ledil CA14026_STRADA-SQ-ME_(LUXEON_XR-M_Linear_1x4)

Lamps: 1 x Lumiled_LUXEON_XR-M_Linear_1x4_1798.32lm@250mA_P=11.005W_I=0.25A

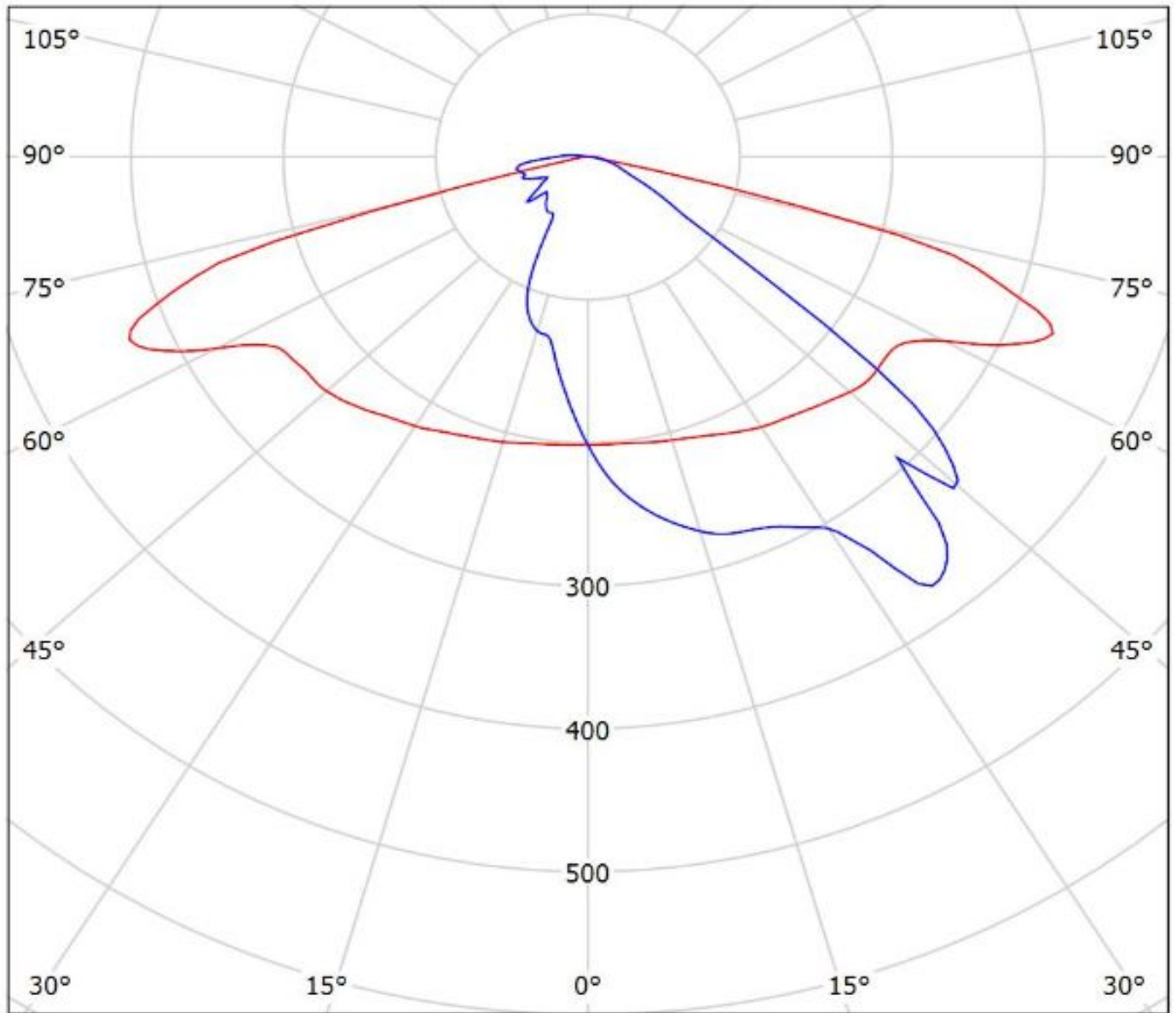

cd/klm

— C0 - C180

— C90 - C270

$\eta = 93\%$

Luminaire: LEDiL Oy CA14026_STRADA-SQ-ME_(NV4x144A)
Lamps: 1 x Nichia_NV4x144A_477.901lm@250mA_P=2.8042W_I=0.250A

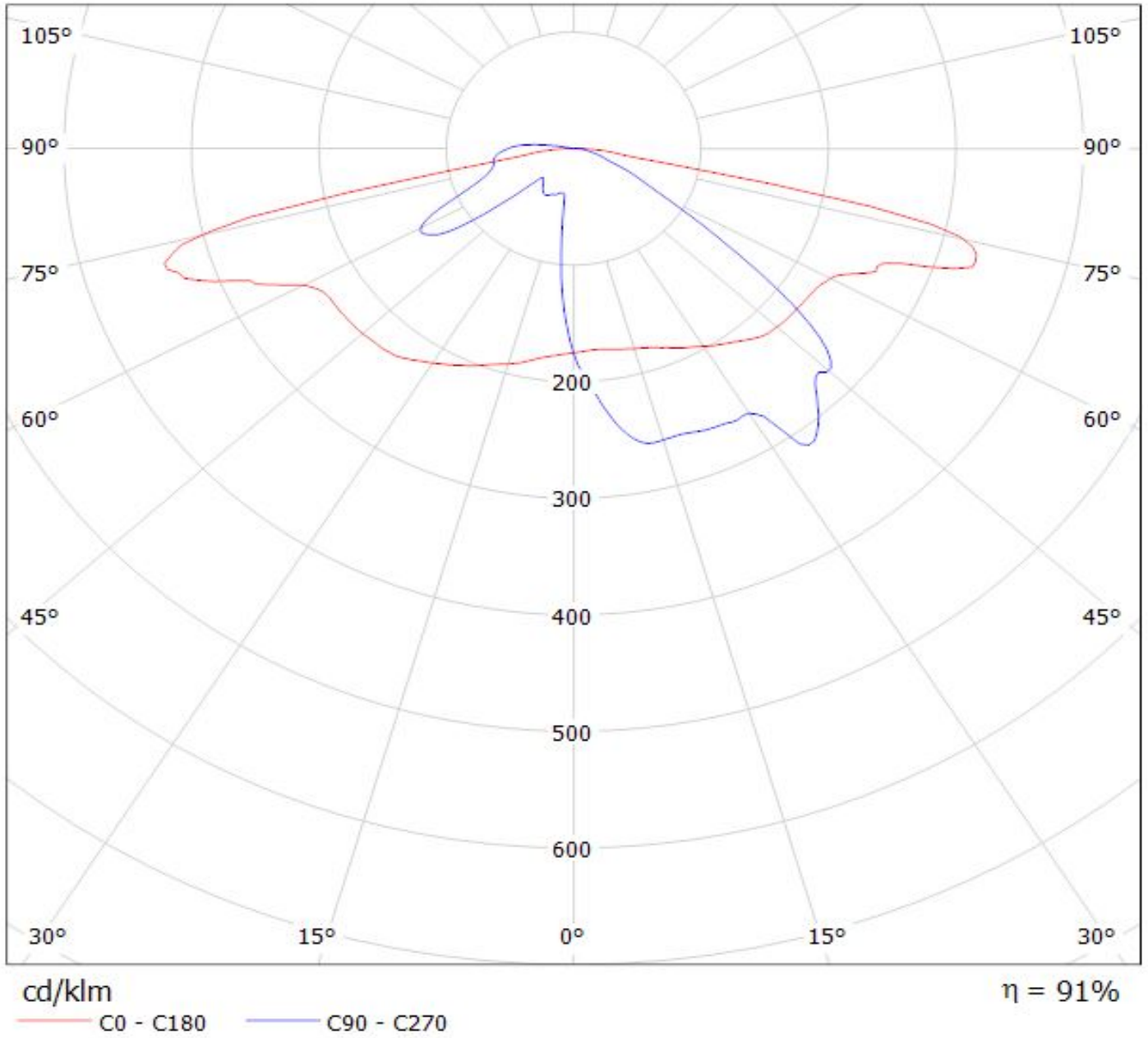

Luminaire: Ledil Oy CA14026_STRADA-SQ-ME_(NVSxx19C)_SIMULATED
Lamps: 1 x Nichia NVSW219C

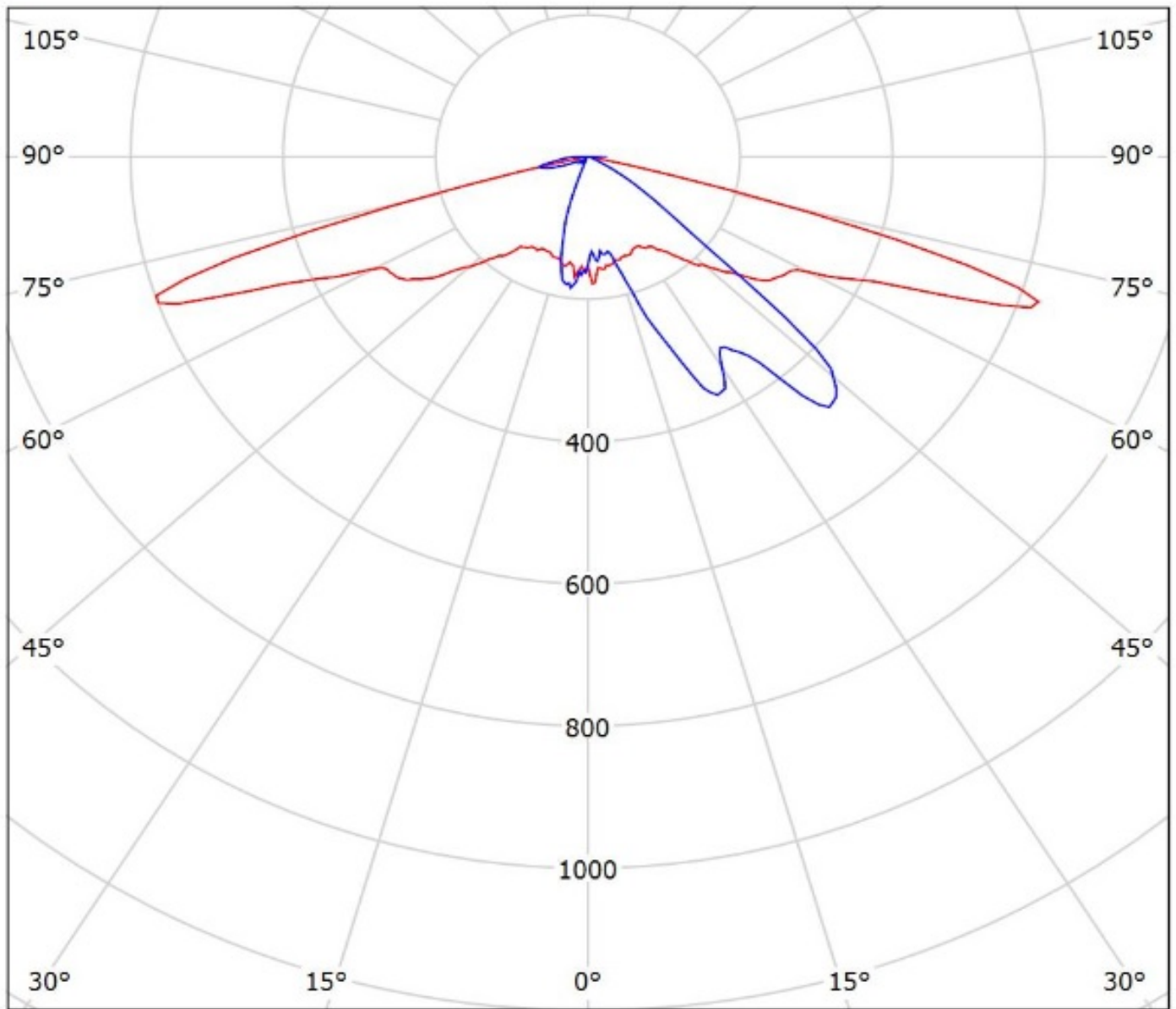

cd/klm

— C0 - C180 — C90 - C270

$\eta = 92\%$

Luminaire: Ledil CA14026_STRADA-SQ-ME_(Duris_S10)

Lamps: 1 x Osram_Duris_S10_(GW-P7LP32.EM)_999.98lm@250mA_P=9.2345W_I=0.25A

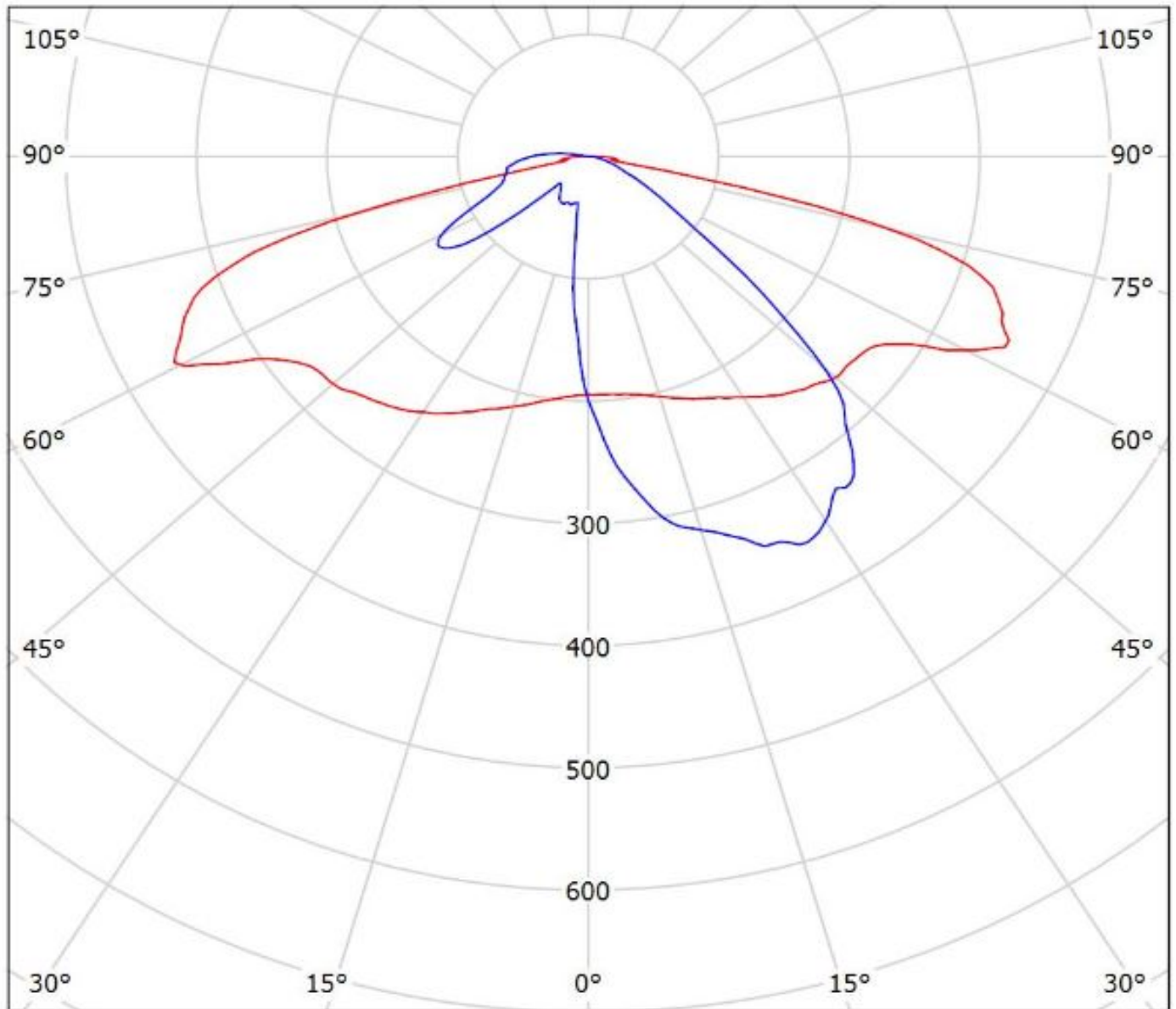

cd/klm

— C0 - C180

— C90 - C270

$\eta = 90\%$

NOTE: The typical divergence will be changed by different color, chip size and chip position tolerance. The typical total divergence is the full angle measured where the luminous intensity is half of the peak value.