

ISSUE 1; January 2016

**Description**

- STATEK's CX4 quartz crystals are hermetically sealed in an ultra-miniature low profile surface mount ceramic package. This high quality quartz resonator forms the basis of a stable oscillator.
- -C SM1 Gold Plated (lead free) ceramic lid
- -C SM4 Solder Plated (lead free) ceramic lid
- -C SM5 Solder Dipped (lead free) ceramic lid
- -SM1 Gold Plated (lead free) glass lid
- -SM4 Solder Plated (lead free) glass lid
- -SM5 Solder Dipped (lead free) glass lid
- The CX4 family of surface mount crystals are ideal for small, high density, battery operated portable products. The CX4 crystal designed in a Pierce oscillator (single inverter) circuit provides very low current consumption and high stability.
- A conventional CMOS Pierce oscillator circuit is shown below. The crystal is effectively inductive and in a PI network circuit with CD and CG provides the additional phase shift necessary to sustain oscillation. The oscillation frequency (f0) is 50 to 250 ppm above the crystal's series resonant frequency (fS).
- Drive Level:  
RA is used to limit the crystal's drive level by forming a voltage divider between RA and CD. RA also stabilizes the oscillator against changes in the amplifiers output resistance (RO). RA should be increased for higher voltage operation.
- The CX4 crystal calibration tolerance is influenced by the effective circuit capacitances, specified as the load capacitance (CL). CL is approximately equal to:  $CL = ((CD \times CG)/(CD + CG)) + CS$
- NOTE: CD and CG include stray layout to ground and CS is the stray shunt capacitance between the crystal terminal. In practice, the effective value of CL will be less than that calculated from CD, CG and CS values because of the effect of the amplifier output resistance. CS should be minimized.
- The oscillation frequency (f0) is approximately equal to:

$$f_0 = f_S [1 + (C_1 / (2(C_0 + CL)))]$$

Where fS = Series resonant frequency of the crystal  
C1 = Motional Capacitance  
C0 = Shunt Capacitance

- Please note that all data is only valid at 25°C unless otherwise stated.

**Frequency Parameters**

- Frequency 600.0kHz to 2.5MHz
- Frequency Tolerance ±500.00ppm to ±10,000.00ppm
- Tolerance Condition @ 25°C
- Ageing ±5ppm max in 1st year @ 25°C
- Turning Point To<sup>2</sup>: 35°C
- Temperature Coefficient: -0.035ppm/°C<sup>2</sup> typ
- Note: Frequency f at temperature T is related to frequency fo at turning point temperature To by:  $((f-f_0)/f_0) = k(T-T_0)^2$



**Outline (mm) -SM1 = Gold Plated (lead free) glass lid**

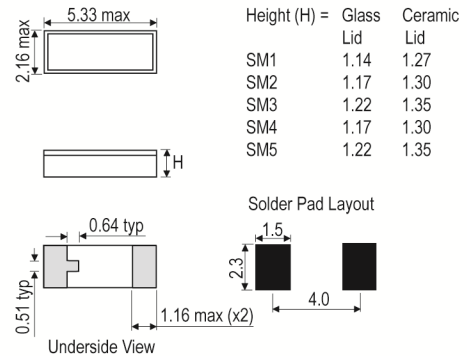

**Conventional CMOS Pierce Oscillator Circuit**

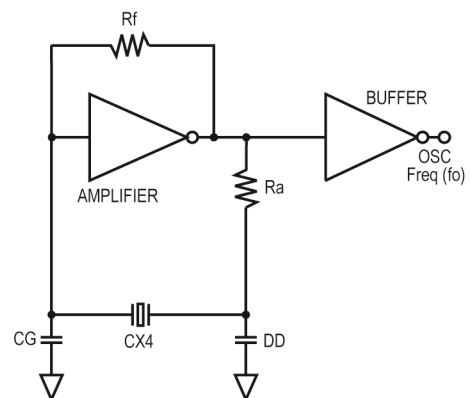

**Sales Office Contact Details:**

UK: +44 (0)1460 270200  
Germany: 0800 1808 443

France: 0800 901 383  
USA: +1.760.318.2824

Email: [info@iqdfrequencyproducts.com](mailto:info@iqdfrequencyproducts.com)  
Web: [www.iqdfrequencyproducts.com](http://www.iqdfrequencyproducts.com)

### Electrical Parameters

■ Load Capacitance (CL)	7.0pF				
■ Shunt Capacitance (C0)	1pF typ				
■ Drive Level	3μW max				
■ Parameters	Fundamental		Overtone		
Frequency, (Hz)	600k	1.0M	1.4M	1.8432M	2.4576M
Motional Resistance, R1 (Ω)	300	400	600	500	1000
Motional Resistance, R1 max	3kΩ				
Motional Capacitance, C1 (fF)	3.5	2.0	1.3	3.5	1.5
Quality Factor, Q (k)	250	200	150	80	45
Shunt Capacitance, Co (pF)	1.0	0.8	0.7	1.0	0.8

### Operating Temperature Ranges

- -10 to 70°C
- -40 to 85°C
- -55 to 125°C

### Environmental Parameters

- Shock: 1500g, 0.3ms, 1/2 sine
- Vibration: 20G rms, 10-2000Hz Random
- Storage Temperature Range: -55 to 125°C

### Manufacturing Details

- Process Temperature: 260°C for 20sec max

### Ordering Information

- Example:  
1.0MHz CX4 EXT -SM1  
500ppm -40 to 85C 7 FUND
- Minimum required\*  
Frequency\*  
Model\*  
Termination\*  
Frequency Tolerance\*  
Operating Temperature Range\*  
Load Capacitance

### Compliance

- RoHS Status (2011/65/EU)      Optional
- REACh Status                      Compliant
- MSL Rating (JDEC-STD-033):    Not Applicable

### Packaging Details

- Pack Style: Reel      Tape & reel in accordance with EIA-481-D  
Pack Size: 1,000
- Pack Style: Tray      Supplied on a tray  
Pack Size: 1

### Sales Office Contact Details:

UK: +44 (0)1460 270200  
Germany: 0800 1808 443

France: 0800 901 383  
USA: +1.760.318.2824

Email: [info@iqdfrequencyproducts.com](mailto:info@iqdfrequencyproducts.com)  
Web: [www.iqdfrequencyproducts.com](http://www.iqdfrequencyproducts.com)

Electrical Specification - maximum limiting values

Frequency Min	Frequency Max	Temperature Range	Stability (Min)	Over Tone Order	ESR
		°C	ppm		Ω
600.0kHz	1.4MHz	-10 to 70 -40 to 85 -55 to 125		Fundamental	600
1.8432MHz	2.5MHz	-10 to 70 -40 to 85 -55 to 125		3OT	1,000

\*Stability Maximum values  $\pm 0$ ppm

This document was correct at the time of printing; please contact your local sales office for the latest version.

[Click to view latest version on our website.](#)

**Sales Office Contact Details:**

UK: +44 (0)1460 270200  
Germany: 0800 1808 443

France: 0800 901 383  
USA: +1.760.318.2824

Email: [info@iqdfrequencyproducts.com](mailto:info@iqdfrequencyproducts.com)  
Web: [www.iqdfrequencyproducts.com](http://www.iqdfrequencyproducts.com)