

White Backlight LED Driver For Medium to Large LCD Panels (Switching Regulator Type)

BD8119FM-M

General Description

BD8119FM-M is a white LED driver with the capability to withstand high input voltage (36V Max).

This driver has 4ch constant-current drivers integrated in 1-chip. Each channel can draw up to 150mA max for driving high brightness on LED. A current-mode buck-boost DC/DC controller is also integrated to achieve stable operation against unstable car-battery voltage input. This also removes the constraint of the number of LEDs in series connection. The brightness can be controlled by either PWM or VDAC techniques.

Features

- Integrated buck-boost current-mode DC/DC controller
- Four integrated LED current driver channels (150mA Max each channel)
- PWM Light Modulation (Minimum Pulse Width 25 μ s)
- Built-in protection functions (UVLO, OVP, TSD, OCP, SCP)
- Abnormal status detection function (OPEN/ SHORT)

Applications

Backlight for car navigation, dashboard panels, etc.

Key Specifications

- Input Supply Voltage Range: 5.0V to 30V
- Standby Current: 4 μ A (Typ)
- LED Maximum Output Current: 150mA(Max)
- Operating Temperature Range: -40°C to +95°C

Package

W(Typ) x D(Typ) x H(Max)



Pin Configuration

(TOP VIEW)

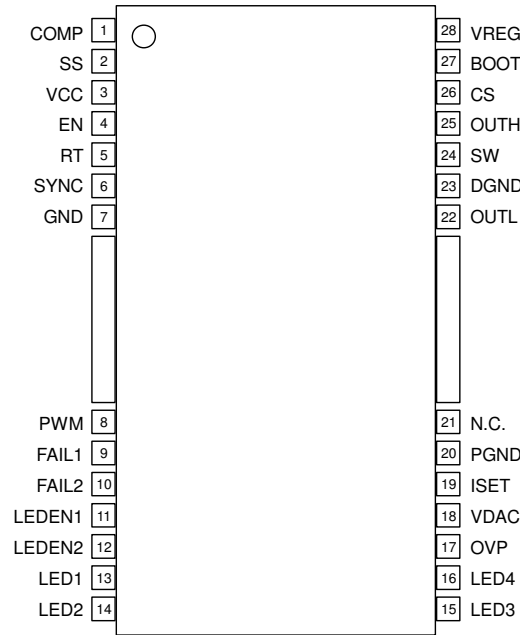

Pin Descriptions

Pin	Symbol	Function	Pin	Symbol	Function
1	COMP	Error amplifier output	15	LED3	LED output 3
2	SS	Soft start time-setting capacitance input	16	LED4	LED output 4
3	VCC	Input power supply	17	OVP	Over-voltage detection input
4	EN	Enable input	18	VDAC	DC variable light modulation input
5	RT	Oscillation frequency-setting resistance input	19	ISET	LED output current-setting resistance input
6	SYNC	External synchronization signal input	20	PGND	LED output GND
7	GND	Small-signal GND	21	-	No Connection
8	PWM	PWM light modulation input	22	OUTL	Low-side external MOSFET Gate Drive output
9	FAIL1	Failure signal output	23	DGND	Low-side internal MOSFET Source output
10	FAIL2	LED open/short detection signal output	24	SW	High-side external MOSFET Source pin
11	LEDEN1	LED output enable pin 1	25	OUTH	High-side external MOSFET Gate Drive outpin
12	LEDEN2	LED output enable pin 2	26	CS	DC/DC Current Sense Pin
13	LED1	LED output 1	27	BOOT	High-side MOSFET Power Supply pin
14	LED2	LED output 2	28	VREG	Internal reference voltage output

Block Diagram

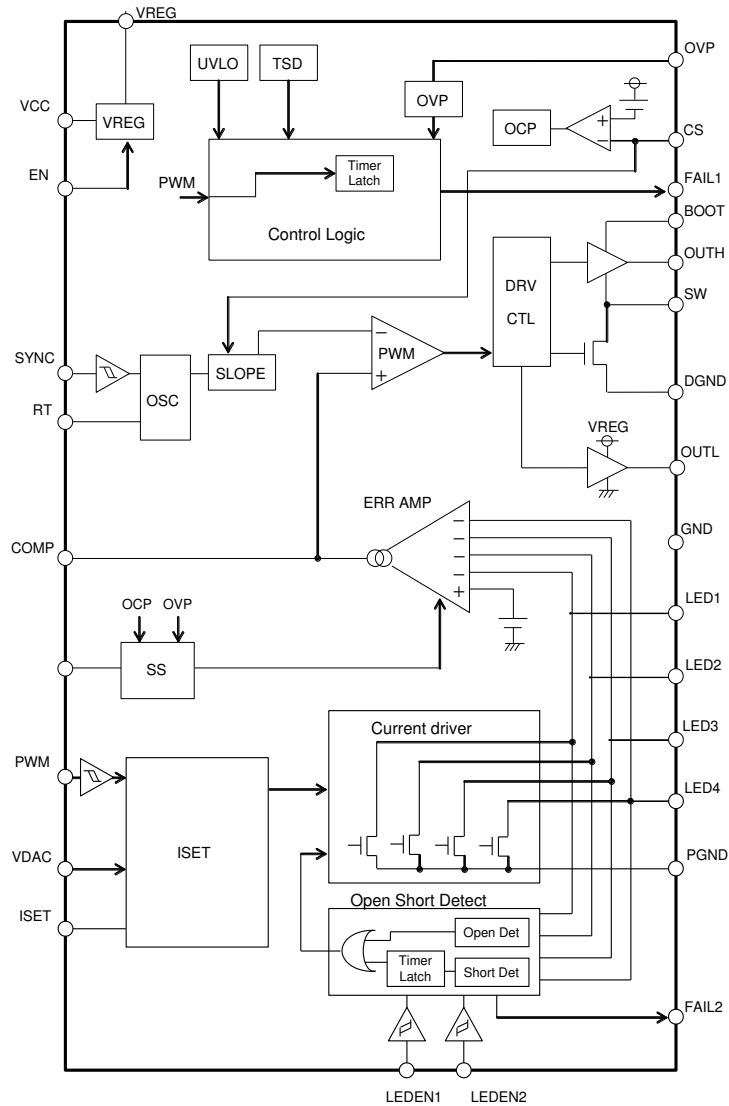

Absolute Maximum Ratings (Ta=25°C)

Parameter	Symbol	Rating	Unit
Power Supply Voltage	V _{CC}	36	V
BOOT ,OUTH Voltage	V _{BOOT} , V _{OUTH}	41	V
SW,CS Voltage	V _{SW} , V _{CS} , V _{OUTH}	36	V
BOOT-SW Voltage	V _{BOOT-SW}	7	V
LED Output Voltage	V _{LED1} , V _{LED2} , V _{LED3} , V _{LED4}	36	V
VREG, OVP, OUTL, FAIL1, FAIL2, LEDEN1, LEDEN2, ISET, VDAC, PWM, SS, COMP, RT, SYNC, EN Voltage	V _{REG} , V _{OVP} , V _{OUTL} , V _{FAIL1} , V _{FAIL2} , V _{LEDEN1} , V _{LEDEN2} , V _{ISET} , V _{VDAC} , V _{PWM} , V _{SS} , V _{COMP} , V _{RT} , V _{SYNC} , V _{EN}	-0.3 to +7 < V _{CC}	V
Power Consumption	P _d	2.20 ^(Note 1)	W
Operating Temperature Range	T _{opr}	-40 to +95	°C
Storage Temperature Range	T _{stg}	-55 to +150	°C
LED Maximum Output Current	I _{LED}	150 ^(Note 2) ^(Note 3)	mA

(Note 1) IC mounted on glass epoxy board measuring 70mm x 70mm x 1.6mm, power dissipated at a rate of 17.6mw/°C at temperatures above 25°C.

(Note 2) Dispersion figures for LED maximum output current and V_F are correlated. Please refer to data on separate sheet.

(Note 3) Amount of current per channel.

Caution: Use of the IC in excess of absolute maximum ratings (such as the input voltage or operating temperature range) may result in damage to the IC. Assumptions should not be made regarding the state of the IC (e.g., short mode or open mode) when such damage is suffered. If operational values are expected to exceed the maximum ratings for the device, consider adding protective circuitry (such as fuses) to eliminate the risk of damaging the IC.

Recommended Operating Conditions (Ta=25°C)

Parameter	Symbol	Rating	Unit
Power Supply Voltage	V _{CC}	5.0 to 30	V
Oscillating Frequency Range	f _{OSC}	250 to 550	kHz
External Synchronization Frequency Range ^(Note 4) ^(Note 5)	f _{SYNC}	f _{OSC} to 550	kHz
External Synchronization Pulse Duty Range	f _{SDUTY}	40 to 60	%

(Note 4) Connect SYNC to GND or OPEN when not using external frequency synchronization.

(Note 5) Do not switch between internal and external synchronization when an external synchronization signal is inputted to the device.

Electrical Characteristics (unless otherwise specified, $V_{CC}=12V$ $T_a=25^{\circ}C$)

Parameter	Symbol	Limit			Unit	Conditions
		Min	Typ	Max		
Circuit Current	I_{CC}	-	7	14	mA	EN=Hi, SYNC=Hi, RT=OPEN PWM=Low, ISET=OPEN, $C_{IN}=10\mu F$
Standby Current	I_{ST}	-	4	8	μA	EN=Low
[VREG Block (VREG)]						
Reference Voltage	V_{REG}	4.5	5	5.5	V	$I_{REG}=-5mA$, $C_{REG}=2.2\mu F$
[OUTH Block]						
OUTH High-side ON-Resistance	R_{ONHH}	1.0	3	4.5	Ω	$I_{ON}=-10mA$
OUTH Low-side ON-Resistance	R_{ONHL}	0.5	2	3.0	Ω	$I_{ON}=10mA$
Over-Current Protection Operating Voltage	V_{OLIMIT}	$V_{CC}-0.66$	$V_{CC}-0.6$	$V_{CC}-0.54$	V	
[OUTL Block]						
OUTL High-side ON-Resistance	R_{ONLH}	1.0	3	4.5	Ω	$I_{ON}=-10mA$
OUTL Low-side ON-Resistance	R_{ONLL}	0.5	2	3.0	Ω	$I_{ON}=10mA$
[SW Block]						
SW Low-side ON-Resistance	R_{ON_SW}	1.0	2.0	4.0	Ω	$I_{ON_SW}=10mA$
[Error Amplifier Block]						
LED Voltage	V_{LED}	0.9	1.0	1.1	V	
COMP Sink Current	$I_{COMPSINK}$	15	25	35	μA	$V_{LED}=2V$, $V_{COMP}=1V$
COMP Source Current	$I_{COMPSOURCE}$	-35	-25	-15	μA	$V_{LED}=0V$, $V_{COMP}=1V$
[Oscillator Block]						
Oscillating Frequency	f_{OSC}	250	300	350	KHz	$R_{RT}=100k\Omega$
[OVP Block]						
Over-voltage Detection Reference Voltage	V_{OVP}	1.9	2.0	2.1	V	V_{OVP} =Sweep up
OVP Hysteresis Width	V_{OHYS}	0.45	0.55	0.65	V	V_{OVP} =Sweep down
SCP Latch OFF Delay Time	t_{SCP}	70	100	130	ms	$R_{RT}=100k\Omega$
[UVLO Block]						
UVLO Voltage	V_{UVLO}	4.0	4.3	4.6	V	V_{CC} : Sweep down
UVLO Hysteresis Width	V_{UHYS}	50	150	150	mV	V_{CC} : Sweep up

Electrical Characteristics – continued (unless otherwise specified, $V_{CC}=12V$ $T_a=25^{\circ}C$)

Parameter	Symbol	Limit			Unit	Conditions
		Min	Typ	Max		
[LED Output Block]						
LED Current Relative Dispersion Width	ΔI_{LED1}	-3	-	+3	%	$I_{LED}=50mA$, $\Delta I_{LED1}=(I_{LED}I_{LED_AVG}-1) \times 100$
LED Current Absolute Dispersion Width	ΔI_{LED2}	-5	-	+5	%	$I_{LED}=50mA$, $\Delta I_{LED2}=(I_{LED}50mA-1) \times 100$
ISET Voltage	V_{ISET}	1.96	2.0	2.04	V	$R_{ISET} = 120k\Omega$
PWM Minimum Pulse Width	T_{min}	25	-	-	μs	$f_{PWM}=150Hz$, $I_{LED}=50mA$
PWM Maximum Duty	D_{max}	-	-	100	%	$f_{PWM}=150Hz$, $I_{LED}=50mA$
PWM Frequency	f_{PWM}	-	-	20	KHz	Duty=50%, $I_{LED}=50mA$
VDAC Gain	G_{VDAC}	-	25	-	mA/V	$V_{DAC}=0V$ to $2V$, $R_{ISET}=120k\Omega$ $I_{LED}=V_{DAC} \div R_{ISET} \times Gain$
Open Detection Voltage	V_{OPEN}	0.2	0.3	0.4	V	V_{LED} = Sweep down
LED Short Detection Voltage	V_{SHORT}	4.4	4.7	5.0	V	V_{OVP} = Sweep up
LED Short Latch OFF Delay Time	t_{SHORT}	70	100	130	ms	$R_{RT}=100k\Omega$
PWM Latch OFF Delay Time	t_{PWM}	70	100	130	ms	$R_{RT}=100k\Omega$
[Logic Inputs (EN, SYNC, PWM, LEDEN1, LEDEN2)]						
Input HIGH Voltage	V_{INH}	2.1	-	5.5	V	
Input LOW Voltage	V_{INL}	GND	-	0.8	V	
Input Current 1	I_{IN}	20	35	50	μA	$V_{IN}=5V$ (SYNC, PWM, LEDEN1, LEDEN2)
Input Current 2	I_{EN}	15	25	35	μA	$V_{EN}=5V$ (EN)
[FAIL Output (Open Drain)]						
FAIL LOW Voltage	V_{OL}	-	0.1	0.2	V	$I_{OL}=0.1mA$

Typical Performance Curves (Unless otherwise specified, Ta=25°C)

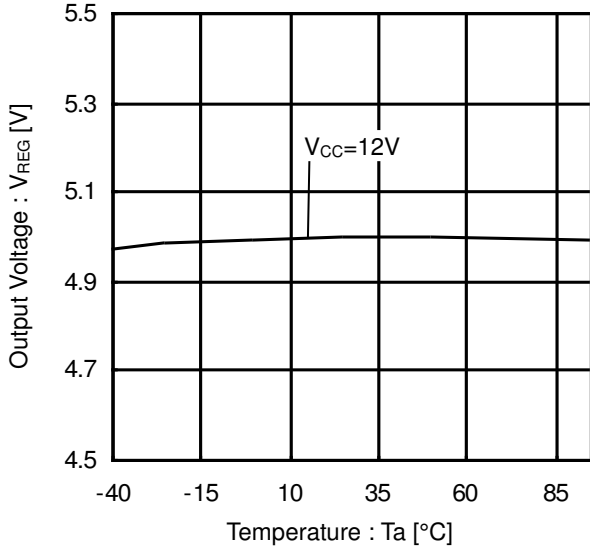

Figure 1. Output Voltage vs Temperature

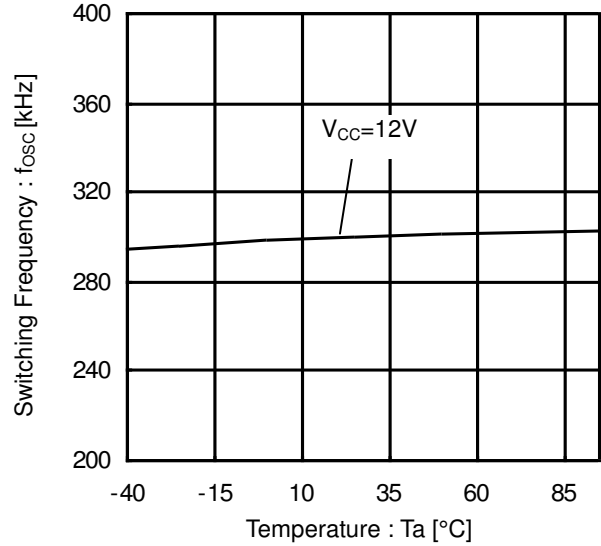

Figure 2. Switching Frequency vs Temperature

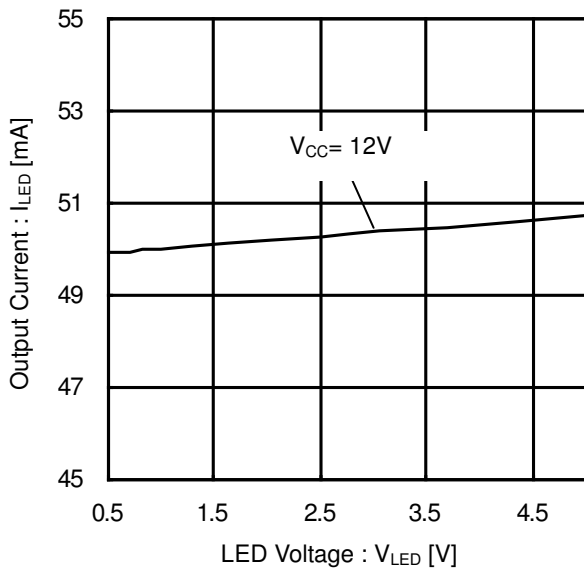

Figure 3. Output Current vs LED Voltage (I_{LED} Depend on V_{LED})

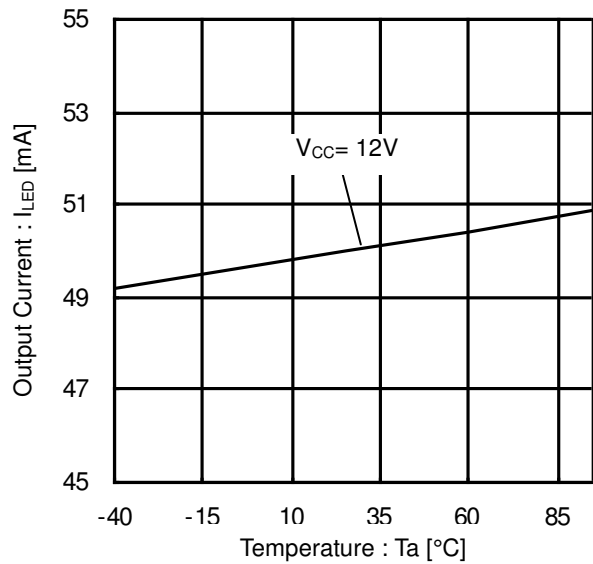

Figure 4. Output Current vs Temperature

Typical Performance Curves – continued

(Unless otherwise specified, $T_a=25^\circ\text{C}$)

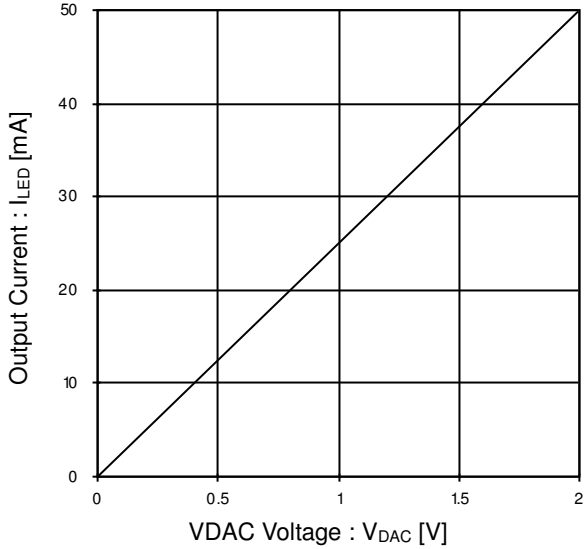

Figure 5. Output Current vs VDAC Voltage (VDAC Gain①)

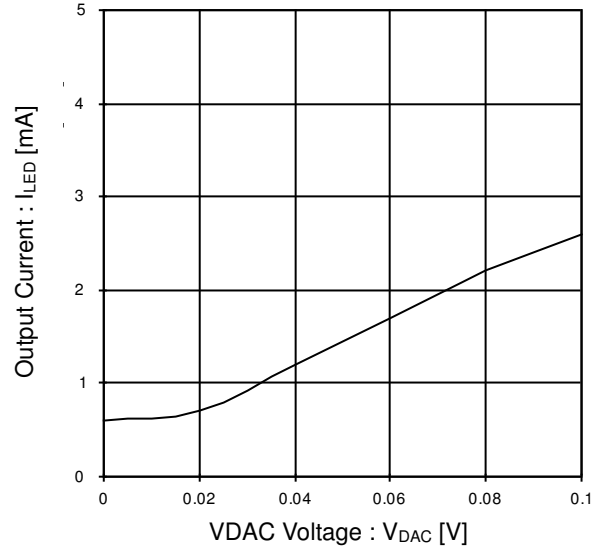

Figure 6. Output Current vs VDAC Voltage (VDAC Gain②)

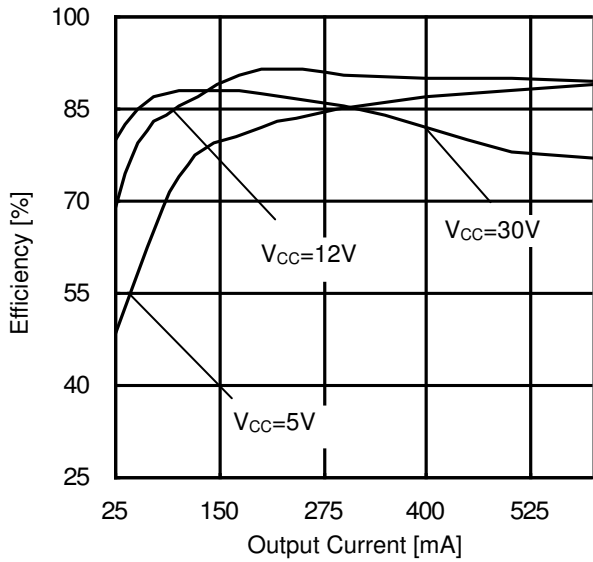

Figure 7. Efficiency vs Output Current (Depend on Input Voltage)

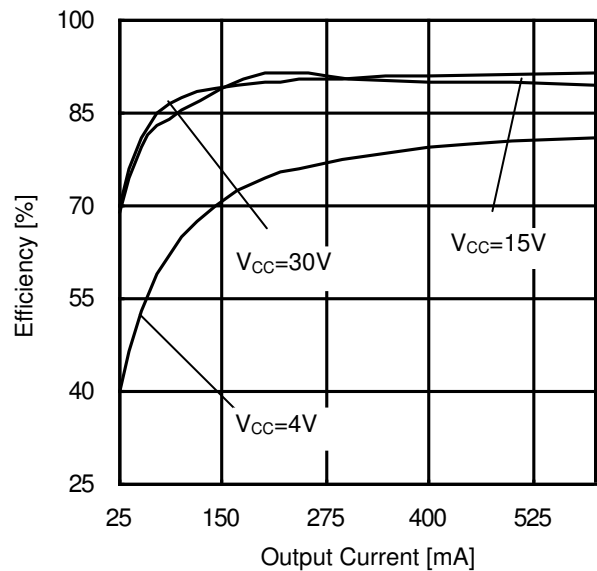

Figure 8. Efficiency vs Output Current (Depend on Output Voltage)

Typical Performance Curves – continued

(Unless otherwise specified, $T_a=25^\circ\text{C}$)

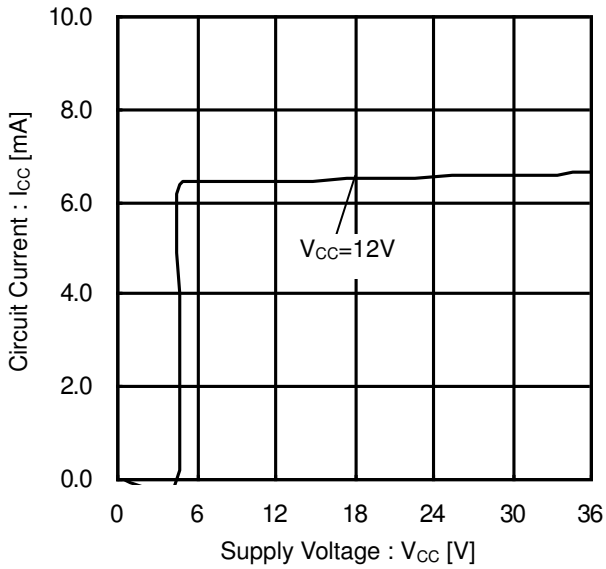

Figure 9. Circuit Current vs Supply Voltage (Switching OFF)

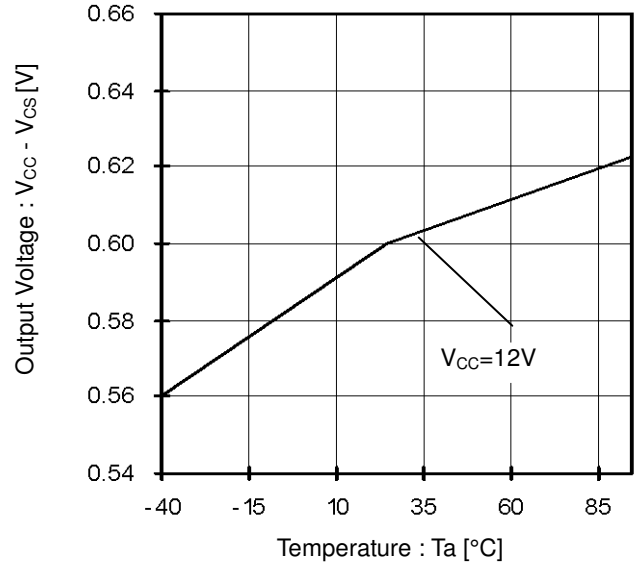

Figure 10. Output Voltage vs Temperature (Over-current Detection Voltage Temperature Characteristic)

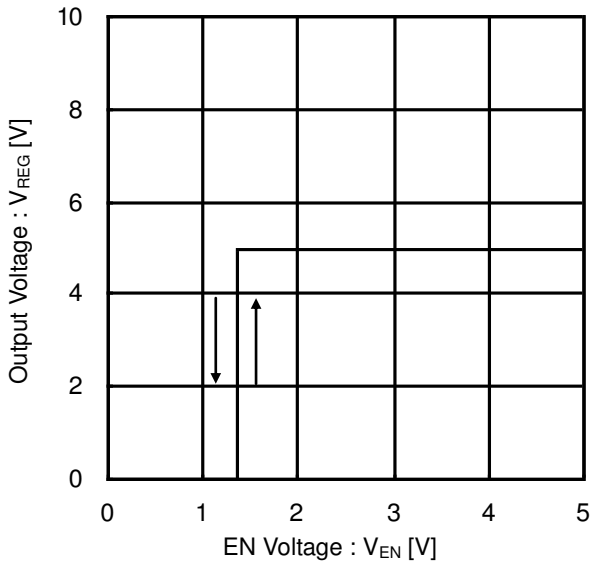

Figure 11. Output Voltage vs EN Threshold Voltage

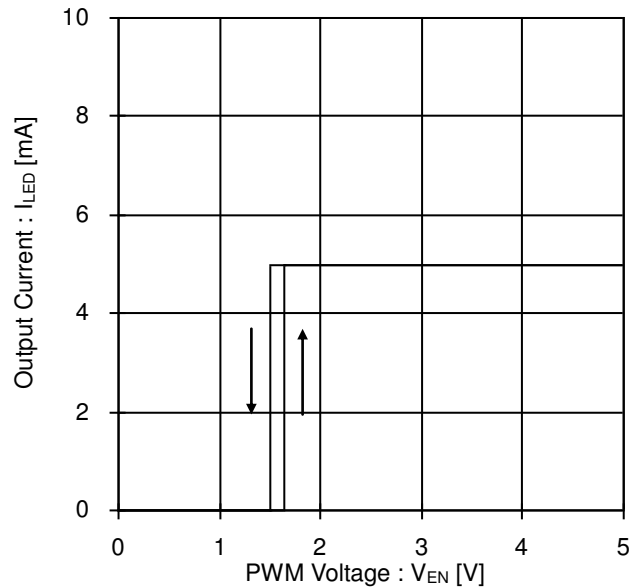

Figure 12. Output Current vs PWM Threshold Voltage

Application Information

1. 5V Voltage Reference (VREG)

5V (Typ) is generated from the VCC input voltage when the enable pin is set high. This voltage is used to power the internal circuitry as well as the voltage source for device pins that need to be fixed to a logical HIGH.

UVLO protection is integrated into the VREG pin. The voltage regulation circuitry operates uninterrupted for output voltages higher than 4.5V (Typ). If output voltage drops to 4.3V (Typ) or lower, UVLO operates and turns the IC OFF. Connect a capacitor (C_{REG} = 2.2μF Typ) to the VREG terminal for phase compensation. Operation may become unstable if C_{REG} is not connected.

2. Constant-current LED Drivers

If less than four constant-current drivers are used, unused channels should be switched OFF based on LEDEN pin configuration. The truth table for these pins is shown below. If a driver output is enabled but not used (i.e. left open), the IC's open circuit-detection circuitry will operate. Please keep the unused pins open. The LEDEN terminals are pulled down internally in the IC, so if left open, the IC will recognize them as logic LO. However, they should be connected directly to VREG or fixed to a logic HI when in use.

LED EN		LED			
<1>	<2>	1	2	3	4
L	L	ON	ON	ON	ON
H	L	ON	ON	ON	OFF
L	H	ON	ON	OFF	OFF
H	H	ON	OFF	OFF	OFF

(1) Output Current Setting

LED current is computed based on the following equation:

$$I_{LED} = \min[V_{DAC}, V_{ISET} (= 2.0V)] / R_{SET} \times GAIN \quad [A]$$

(min[V_{DAC}, 2.0V] = the smaller value of either V_{DAC} or V_{ISET}; GAIN = set by internal circuitry.)

In applications where an external signal is used for output current control, a control voltage in the range of 0.1V to 2.0V can be connected on the VDAC pin to control according to the above equation. If an external control signal is not used, connect the VDAC pin to VREG (do not leave the pin open as it may cause IC malfunction). Also, do not switch individual channels on or OFF using LEDEN pin while operating in PWM mode.

The following diagram illustrates the relation between I_{LED} and GAIN.

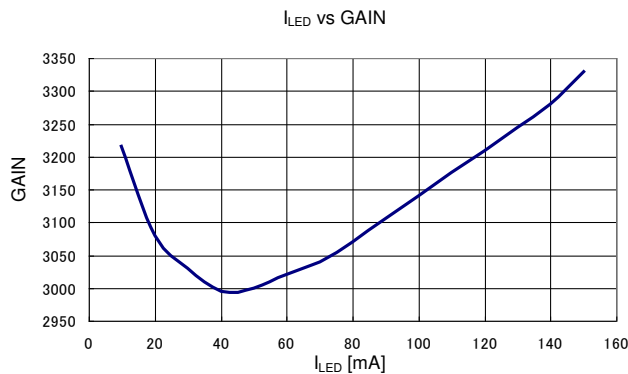

I _{LED} [mA]	GAIN
10	3215
20	3080
30	3030
40	2995
50	3000
60	3020
70	3040
80	3070
90	3105
100	3140
110	3175
120	3210
130	3245
140	3280
150	3330

In PWM intensity control mode, the ON/OFF state of each current driver is controlled directly by the input signal on the PWM pin; thus, the duty ratio of the input signal on the PWM pin equals the duty ratio of the LED current. When not controlling intensity at PWM, fix the PWM terminal to a high voltage (100%). Output light intensity is greatest at 100% input.

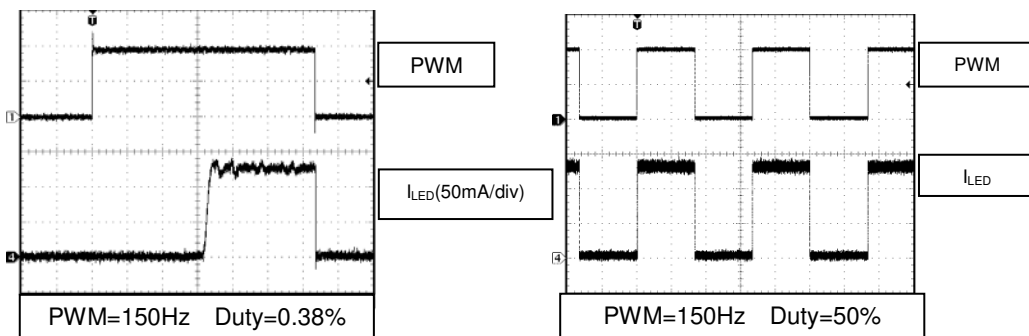

3. Buck-Boost DC/DC Controller

(1) Number of LEDs in Series Connection

Output voltage of the DCDC converter is controlled such that the forward voltage over each of the LEDs on the output is set to 1.0V (Typ). DCDC operation is performed only when the LED output is operating. When two or more LED outputs are operating simultaneously, the LED voltage output is held at 1.0V (Typ) per LED from the set of LEDs in series with the highest V_F value. The voltages of other LED outputs are increased only in relation to the fluctuation of voltage over these LEDs in series. Consideration should be given to the change in power dissipation due to variations in V_F of the LEDs. Please determine the allowable maximum V_F variance of the total LEDs in series by using the description as shown below:

V_F variation allowable voltage 3.7V(Typ) = short detecting voltage 4.7V(Typ) - LED control voltage 1.0V(Typ)

The number of LEDs that can be connected in series is limited due to the open-circuit protection circuit, which engages at 85% of the set OVP voltage. Therefore, the maximum output voltage of the under normal operation becomes $30.6V (= 36V \times 0.85, \text{ where } (30.6 - 1.0V) / V_F > N[\text{maximum number of LEDs in series}]$.

(2) Over-voltage Protection Circuit (OVP)

The output of the DCDC converter should be connected to the OVP pin using a voltage divider. In determining an appropriate trigger voltage for OVP function, consider the total number of LEDs in series and the maximum variation in V_F . Also, bear in mind that over-current protection (OCP) is triggered at $0.85 \times$ OVP trigger voltage. If the OVP function operates, it will not release unless the DCDC voltage drops to 72.5% of the OVP trigger voltage. For example, if R_{OVP1} (output voltage side), R_{OVP2} (GND side), and DCDC voltage V_{OUT} are conditions for OVP, then:

$$V_{OUT} \geq (R_{OVP1} + R_{OVP2}) / R_{OVP2} \times 2.0V$$

OVP will operate when $V_{OUT} > 32V$ if $R_{OVP1} = 330k\Omega$ and $R_{OVP2} = 22k\Omega$.

(3) Buck-boost DC/DC Converter Oscillation Frequency (f_{OSC})

The regulator's internal triangular wave oscillation frequency can be set using a resistor connected to the RT pin (pin 26). This resistor determines the charge/discharge current to the internal capacitor, thereby changing the oscillating frequency. Refer to the following theoretical formula when setting RT:

$$f_{OSC} = \frac{30 \times 10^6}{R_{RT}[\Omega]} \times \alpha \quad [\text{kHz}]$$

30×10^6 (V/A/S) is a constant ($\pm 16.6\%$) determined by the internal circuitry, and α is a correction factor that varies in relation to RT: {RT: $\alpha = 50k\Omega: 0.98, 60k\Omega: 0.985, 70k\Omega: 0.99, 80k\Omega: 0.994, 90k\Omega: 0.996, 100k\Omega: 1.0, 150k\Omega: 1.01, 200k\Omega: 1.02, 300k\Omega: 1.03, 400k\Omega: 1.04, 500k\Omega: 1.045$ }

A resistor in the range of 62.6k Ω to 523k Ω is recommended. Settings that deviate from the frequency range shown below may cause switching to stop, and proper operation cannot be guaranteed.

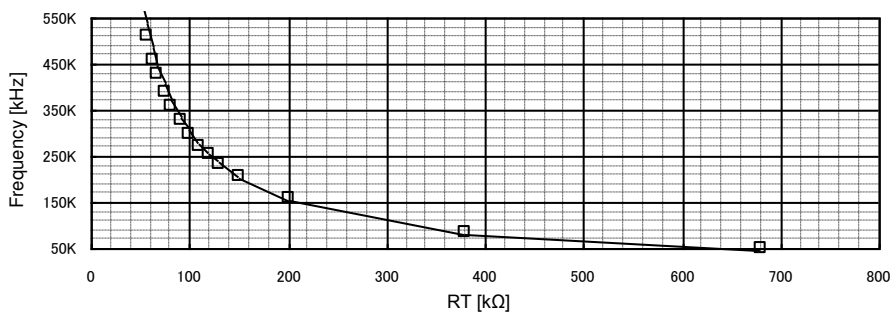

Figure 13. Switching Frequency vs RT

(4) External DC/DC Converter Oscillating Frequency Synchronization (f_{SYNC})

Do not switch from external to internal oscillation of the DC/DC converter if an external synchronization signal is present on the SYNC pin. When the signal on the SYNC terminal is switched from high to low, a delay of about 30 μ s (Typ) occurs before the internal oscillation circuitry starts to operate (only the rising edge of the input clock signal on the SYNC terminal is recognized). Moreover, if external input frequency is less than the internal oscillation frequency, the internal oscillator will operate after the above-mentioned 30 μ s (Typ) delay; thus, do not input a synchronization signal with a frequency less than the internal oscillation frequency.

(5) Soft Start Function

The soft-start (SS) limits the current and slows the rise-time of the output voltage during the start-up, hence it leads to prevention of the overshoot on the output voltage and the inrush current.

(6) Self-diagnostic Functions

The operating status of the built-in protection circuitry is propagated to FAIL1 and FAIL2 pins (open-drain outputs). FAIL1 becomes low when UVLO, TSD, OVP, or SCP protection is engaged, whereas FAIL2 becomes low when open or short LED is detected.

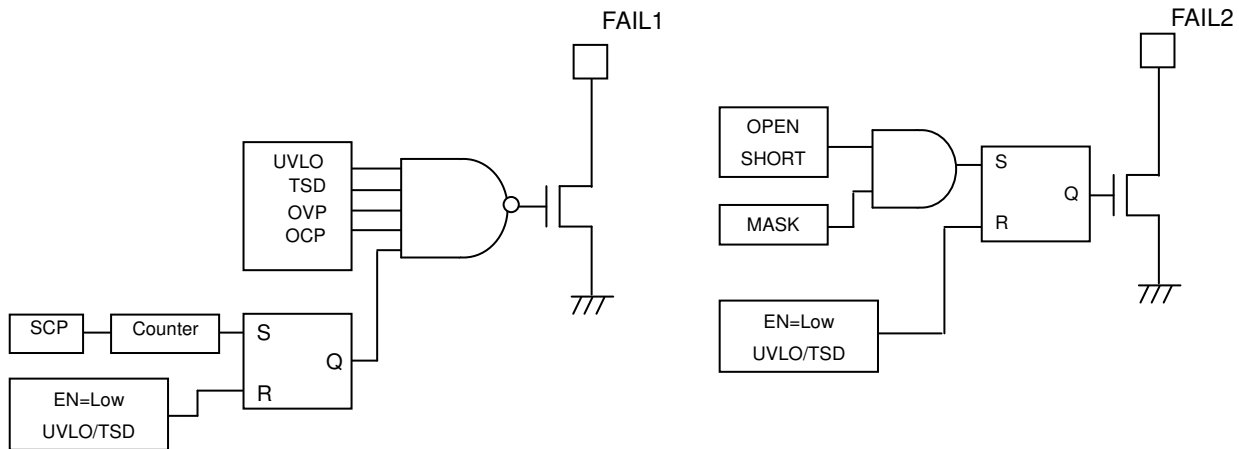

(7) Operation of the Protection Circuitry

(a) Under-Voltage Lock Out (UVLO)

The UVLO shuts down all the circuits other than VREG when $V_{CC} \leq 4.3V$ (Typ).

(b) Thermal Shut Down (TSD)

The TSD shuts down all the circuits other than VREG when the T_j reaches $175^\circ C$ (TYP), and releases when the T_j becomes below $150^\circ C$ (Typ).

(c) Over-Current Protection (OCP)

The OCP detects the current through the power-FET by monitoring the voltage of the high-side resistor, and activates when the CS voltage becomes less than $V_{CC}-0.6V$ (Typ). When the OCP is activated, the external capacitor of the SS pin becomes discharged and the switching operation of the DCDC turns OFF.

(d) Over Voltage Protection (OVP)

The output voltage of the DCDC is detected with the OVP-pin voltage, and the protection activates when the OVP-pin voltage becomes greater than $2.0V$ (Typ). When the OVP is activated, the external capacitor of the SS pin becomes discharged and the switching operation of the DCDC turns OFF.

(8) Short Circuit Protection (SCP)

When the LED-pin voltage becomes less than $0.3V$ (Typ), the internal counter starts operating and latches OFF the circuit approximately after $100ms$ (when $f_{OSC} = 300kHz$). If the LED-pin voltage becomes over $0.3V$ before $100ms$, then the counter resets.

When the LED anode (i.e. DCDC output voltage) is shorted to ground, then the LED current becomes OFF and the LED-pin voltage becomes low. Furthermore, the LED current also becomes OFF when the LED cathode is shorted to ground. Hence in summary, the SCP works with both cases of the LED anode and the cathode being shorted.

(9) LED Open Detection

When the LED-pin voltage $\leq 0.3V$ (Typ) as well as OVP-pin voltage $\geq 1.7V$ (Typ) simultaneously, the device detects as LED open and latches OFF that particular channel.

(10) LED Short Detection

When the LED-pin voltage $\geq 4.7\text{V}$ (Typ) and OVP-pin voltage $\leq 1.6\text{V}$ (Typ) simultaneously, the internal counter starts operating and the only detected channel (as LED short) latches OFF approximately after 100ms (when $f_{\text{OSC}} = 300\text{kHz}$). With the PWM brightness control, the detecting operation is processed only when PWM-pin = High. If the condition of the detection operation is released before 100ms (when $f_{\text{OSC}} = 300\text{kHz}$), then the internal counter resets.

(Note) The counter frequency is the DCDC switching frequency determined by the RT. The latch proceeds at the count of 32770.

Protection	Detecting Condition		Operation after detect
	[Detect]	[Release]	
UVLO	$V_{\text{REG}} < 4.3\text{V}$	$V_{\text{REG}} > 4.5\text{V}$	All blocks shut down
TSD	$T_j > 175^\circ\text{C}$	$T_j < 150^\circ\text{C}$	All blocks (except VREG) shut down
OVP	$V_{\text{OVP}} > 2.0\text{V}$	$V_{\text{OVP}} < 1.45\text{V}$	SS discharges
OCP	$V_{\text{CS}} \leq V_{\text{CC}} - 0.6\text{V}$	$V_{\text{CS}} > V_{\text{CC}} - 0.6\text{V}$	SS discharges
SCP	$V_{\text{LED}} < 0.3\text{V}$ (100ms delay when $f_{\text{OSC}} = 300\text{kHz}$)	EN or UVLO	Counter starts and then latches OFF all blocks (except VREG)
LED open	$V_{\text{LED}} < 0.3\text{V}$ & $V_{\text{OVP}} > 1.7\text{V}$	EN or UVLO	Only the detected channel latches OFF
LED short	$V_{\text{LED}} > 4.7\text{V}$ & $V_{\text{OVP}} < 1.6\text{V}$ (100ms delay when $f_{\text{OSC}} = 300\text{kHz}$)	EN or UVLO	Only the detected channel latches OFF (after the counter sets)

4. Protection Sequence

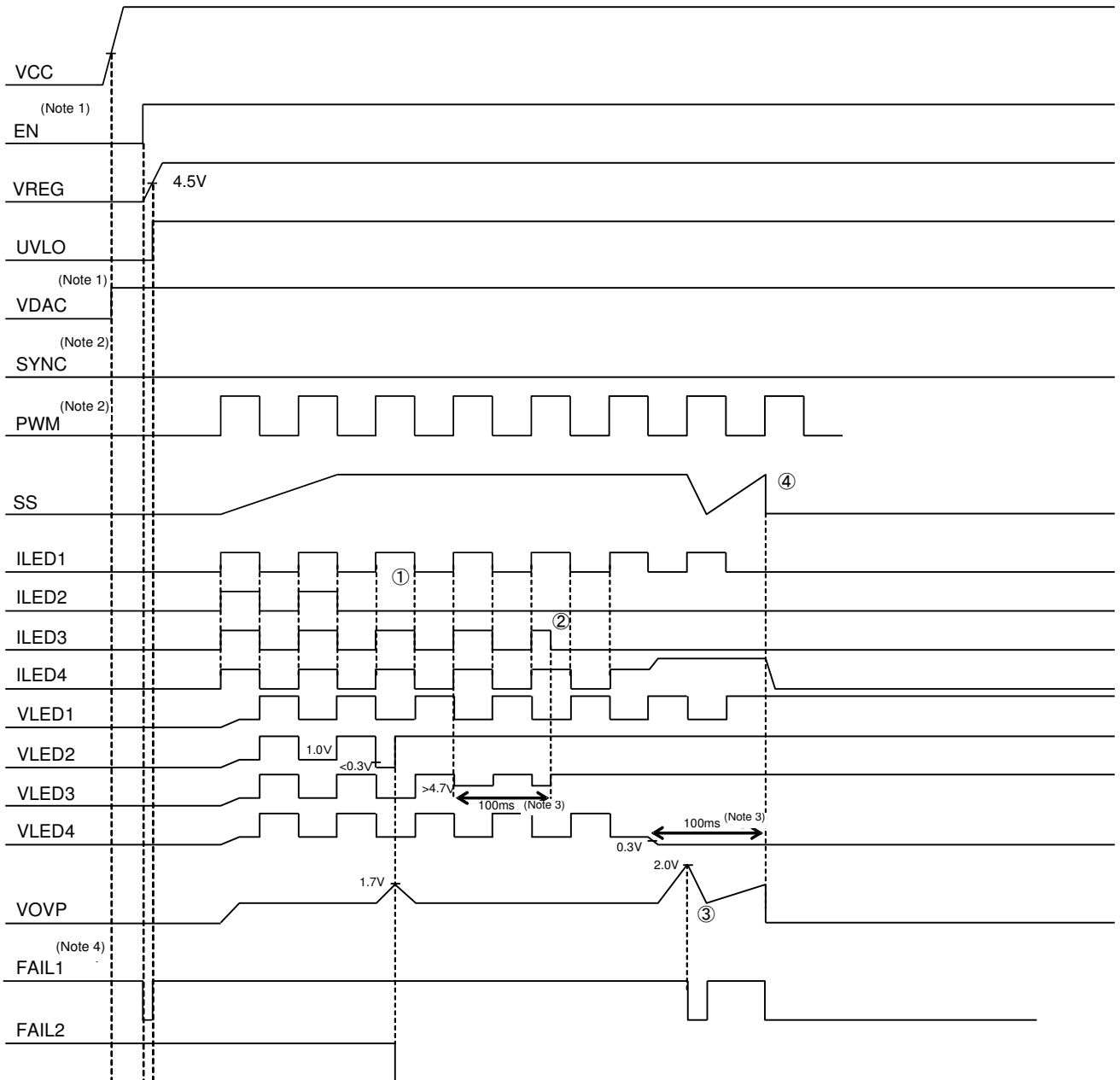

(Note 1) Turn ON the EN after the VCC is ON
 (Note 2) SYNC and PWM inputs are allowed to be on before the VCC is ON
 (Note 3) Approximately 100ms of delay when $f_{OSC} = 300kHz$
 (Note 4) This waveform is pulled up by an external supply.

- ① Case for LED2 in open-mode
 When $V_{LED2} < 0.3V$ and $V_{OVP} > 1.7V$ simultaneously, then LED2 becomes off and FAIL2 becomes low
- ② Case for LED3 in short-mode
 When $V_{LED3} > 4.7V$ and $V_{OVP} < 1.6V$ simultaneously, then LED3 becomes off after 100ms approx
- ③ Case for LED4 in short to GND
 - ③-1 DCDC output voltage increases, and then SS discharges and FAIL1 becomes low
 - ③-2 Detects $V_{LED4} < 0.3V$ and shuts down after approximately 100ms

5. Procedure for External Components Selection

Follow the steps as shown below for selecting the external components

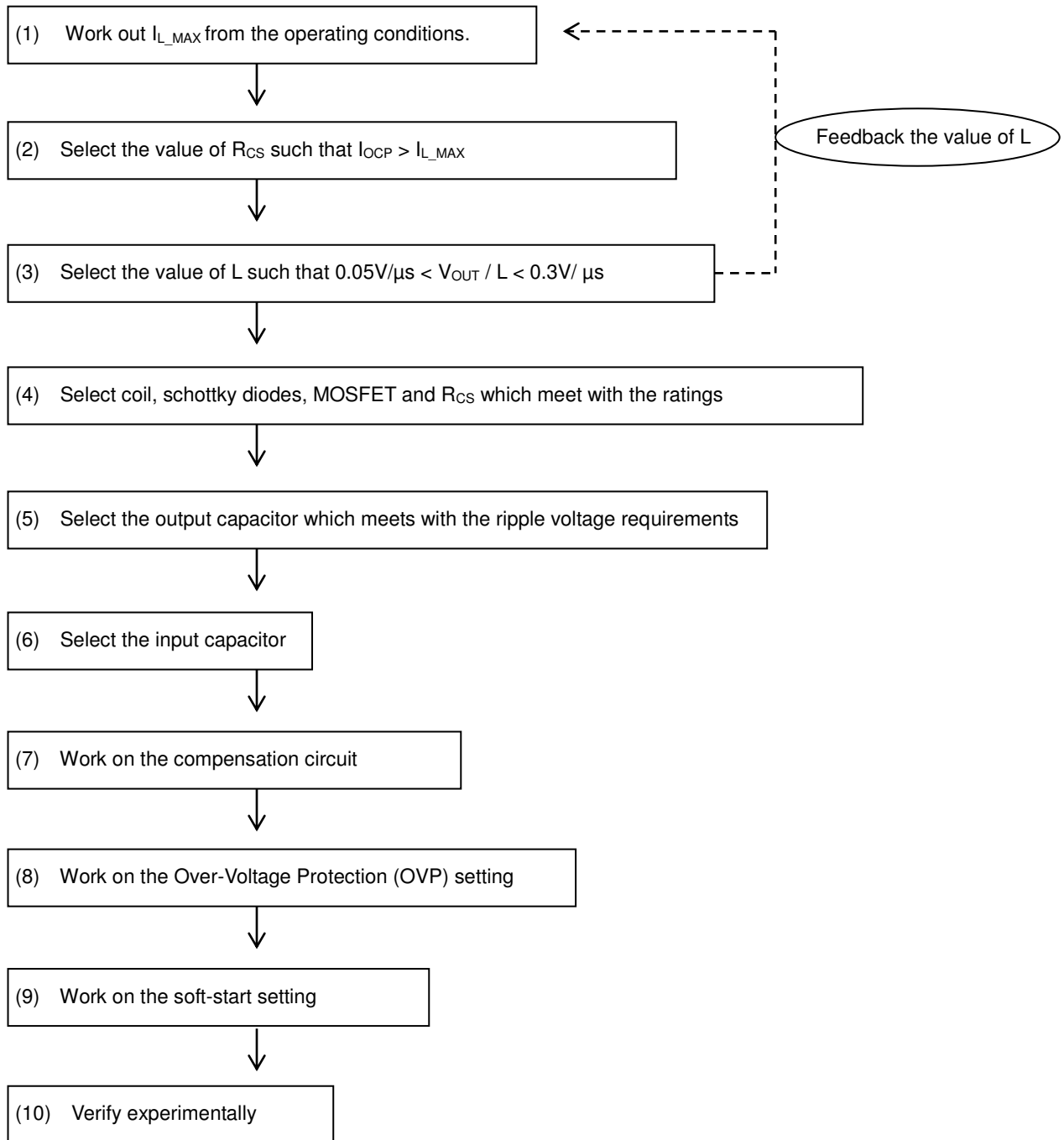

(1) Computation of the Input Peak Current and I_{L_MAX}

① Calculation of the maximum output voltage (V_{OUT_MAX})

To calculate the V_{OUT_MAX} , it is necessary to take into account the V_F variation and the number of LED connected in series.

$$V_{OUT_MAX} = (V_F + \Delta V_F) \times N + 1.0V$$

Where:

ΔV_F is the V_F Variation

N is the Number of LED connection in series

② Calculation of the output current I_{OUT}

$$I_{OUT} = I_{LED} \times 1.05 \times M$$

Where:

M is the Number of LED connections in parallel

③ Calculation of the input peak current I_{L_MAX}

$$I_{L_MAX} = I_{L_AVG} + 1/2 \Delta I_L$$

$$I_{L_AVG} = (V_{IN} + V_{OUT}) \times I_{OUT} / (\eta \times V_{IN})$$

$$\Delta I_L = \frac{V_{IN}}{L} \times \frac{1}{f_{OSC}} \times \frac{V_{OUT}}{V_{IN} + V_{OUT}}$$

Where:

η is the efficiency

f_{OSC} is the switching frequency

- (a) The worst case scenario for V_{IN} is when it is at the minimum, and thus the minimum value should be applied in the equation.
- (b) An L value of 10 μ F to 47 μ F is recommended. The current-mode type of DC/DC conversion is adopted for BD8119FM-M, which is optimized with the use of the recommended L value in the design stage. This recommendation is based upon the efficiency as well as the stability. L values outside this recommended range may cause irregular switching waveform and hence deterioration of stable operation.
- (c) η (efficiency) is approximately 80%

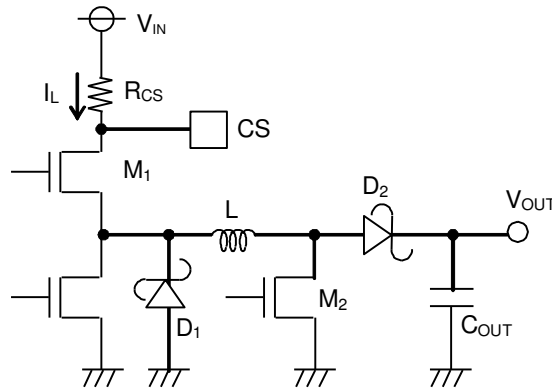

External Application Circuit

(2) The Setting of Over-Current Protection

Choose R_{CS} with the use of the equation $V_{OCP_MIN} (=0.54V) / R_{CS} > I_{L_MAX}$

When investigating the margin, it is worth noting that the L value may vary by approximately $\pm 30\%$.

- (3) The Selection of the L
 In order to achieve stable operation of the current-mode DC/DC converter, we recommend selecting the L value in the range indicated below:

$$0.05[V/\mu s] < \frac{V_{OUT} \times R_{CS}}{L} < 0.3[V/\mu s]$$

The smaller $\frac{V_{OUT} \times R_{CS}}{L}$ allows stability improvement but slows down the response time.

- (4) Selection of coil L, diode D₁ and D₂, MOSFET M₁ and M₂, and R_{CS}

	Current rating	Voltage Rating	Heat Loss
Coil L	> I _{L_MAX}	—	
Diode D ₁	> I _{OCP}	> V _{IN_MAX}	
Diode D ₂	> I _{OCP}	> V _{OUT}	
MOSFET M ₁	> I _{OCP}	> V _{IN_MAX}	
MOSFET M ₂	> I _{OCP}	> V _{OUT}	
R _{CS}	—	—	> I _{OCP} ² × R _{CS}

(Note 1) Allow some margin such as the tolerance of the external components when selecting.
 (Note 2) In order to achieve fast switching, choose a MOSFET with the smaller gate-capacitance.

- (5) Selection of the Output Capacitor
 Select the output capacitor C_{OUT} based on the requirement of the ripple voltage V_{pp}.

$$V_{pp} = \frac{I_{OUT}}{C_{OUT}} \times \frac{V_{OUT}}{V_{OUT} + V_{IN}} \times \frac{1}{f_{OSC}} + \Delta I_L \times R_{ESR}$$

Choose C_{OUT} that allows the V_{pp} to settle within the requirement. Allow some margin also, such as the tolerance of the external components.

- (6) Selection of the Input Capacitor
 A capacitor at the input is also required as the peak current flows between the input and the output in DC/DC conversion. An input capacitor greater than 10μF with the ESR smaller than 100mΩ is recommended. An input capacitor outside the recommended range may cause large ripple voltage at the input and may lead to malfunction.

(7) Phase Compensation Guidelines

In general, the negative feedback loop is stable when the following conditions are met:

Overall gain of 1 (0dB) with a phase lag of less than 150° (i.e., a phase margin of 30° or more)

However, as the DC/DC converter constantly samples the switching frequency, the gain-bandwidth (GBW) product of the entire series should be set to 1/10 the switching frequency of the system. Therefore, the overall stability characteristics of the application are as follows:

- (a) Overall gain of 1 (0dB) with a phase lag of less than 150° (i.e., a phase margin of 30° or more)
- (b) GBW (frequency at gain 0dB) of 1/10 the switching frequency

Thus, to improve response within the GBW product limits, the switching frequency must be increased.

The key for achieving stability is to place fz near to the GBW. The GBW depends on a phase lag "fp1" that is decided by C_{OUT} and output impedance RL. The phase-lead and the phase-lag are the following.

$$\text{Phase-lead } f_z = \frac{1}{2\pi C_{pc} R_{pc}} \quad [Hz]$$

$$\text{Phase-lag } f_{p1} = \frac{1}{2\pi R L C_{OUT}} \quad [Hz]$$

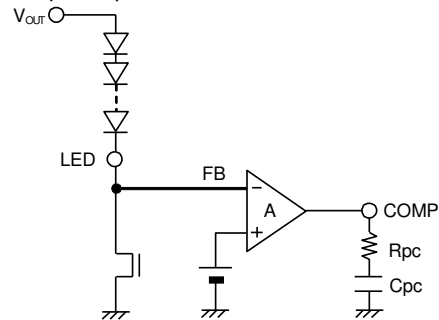

Good stability would be obtained when the fz is set between 1kHz to 10kHz.

In buck-boost applications, Right-Hand-Plane (RHP) Zero exists. This Zero has no gain but a pole characteristic in terms of phase. As this Zero may cause instability when it is in the control loop, it is necessary to bring this zero before the GBW.

$$f_{RHP} = \frac{V_{OUT} + V_{IN}}{2\pi I_{LOAD} L} [Hz]$$

Where:

I_{LOAD} is the Maximum Load Current

It is important to keep in mind that these are not very strict guidelines. Adjustments may have to be made to ensure stability in the actual circuitry. It is also important to note that stability characteristics can change greatly depending on factors such as substrate layout and load conditions. Therefore, when designing for mass-production, stability should be thoroughly investigated and confirmed in the actual physical design.

(8) Setting of the Over-Voltage Protection

We recommend setting the over-voltage protection V_{OVP} from 1.2V to 1.5V greater than V_{OUT} which is adjusted by the number of LEDs in series connection. Less than 1.2V may cause unexpected detection of the LED open and short during the PWM brightness control. For V_{OVP} greater than 1.5V, the LED short detection may become invalid.

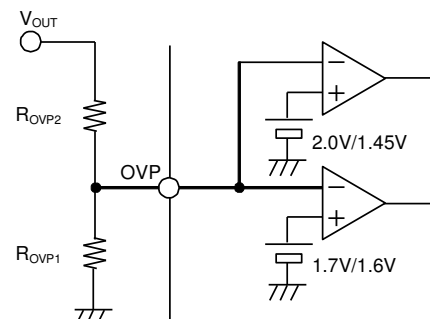

(9) Setting of the Soft-Start

The soft-start allows minimizing the coil current as well as the overshoot of the output voltage at start-up.

For the capacitance, the range of 0.001μF to 0.1μF is recommended. Capacitance less than 0.001μF may cause overshoot on the output voltage. Capacitance greater than 0.1μF may cause massive reverse current through the parasitic elements of the IC that can damage the whole device. In case it is necessary to use the capacitance greater than 0.1μF, provide a reverse current protection diode at the VCC or a bypass diode placed between the SS-pin and the VCC.

Soft-start time t_{SS}

$$t_{SS} = C_{SS} \times 0.7V / 5\mu A \quad [s]$$

Where:

C_{SS} is the capacitance at the SS-pin

(10) Verification of the Operation by Taking Measurements

The overall characteristic may change by load current, input voltage, output voltage, inductance, load capacitance, switching frequency, and the PCB layout. We strongly recommend verifying your design by taking the actual measurements.

Power Dissipation

Power dissipation can be calculated as follows:

$$Pc(N) = I_{CC} \times V_{CC} + 2 \times C_{iss} \times V_{REG} \times f_{SW} \times V_{CC} + [V_{LED} \times N + \Delta V_F \times (N-1)] \times I_{LED}$$

Where:

- I_{CC} is the Maximum circuit current
- V_{CC} is the Supply power voltage
- C_{iss} is the External FET capacitance
- V_{SW} is the SW gate voltage
- f_{SW} is the SE frequency
- V_{LED} is the LED control voltage
- N is the LED parallel numeral
- ΔV_F is the LED V_F fluctuation
- I_{LED} is the LED output current

Sample Calculation:

$$Pc(4) = 10mA \times 30V + 500pF \times 5V \times 300kHz \times 30V + [1.0V \times 4 + \Delta V_F \times 3] \times 100mA$$

$$\Delta V_F = 3.0V, Pc(4) = 322.5mW + 1.3W = 1622.5mW$$

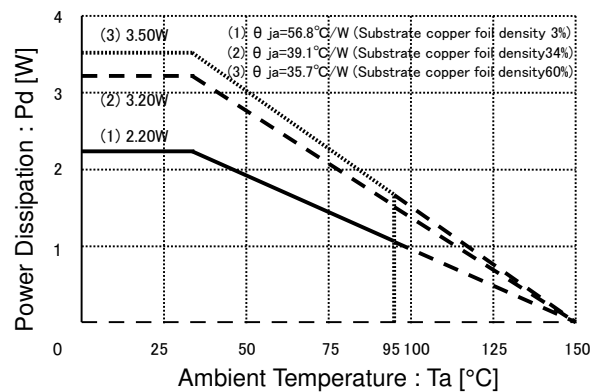
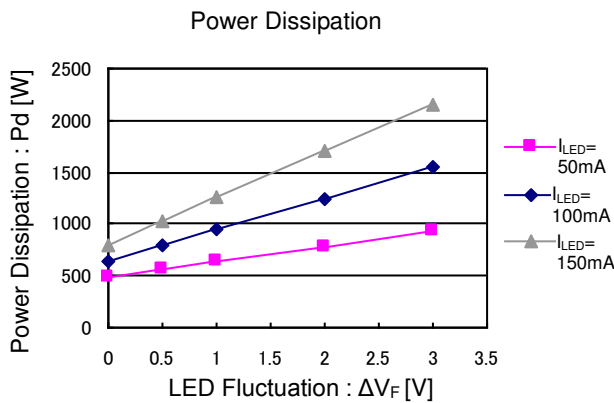

Figure 14

(Note 1) Power dissipation calculated when mounted on 70mm x 70mm x 1.6mm glass epoxy substrate (1-layer platform/copper thickness 18μm)

(Note 2) Power dissipation changes with the copper foil density of the board.

The area of the copper foil becomes the total area of the heat radiation fin and the foot pattern (connected directly with IC) of this IC. This value represents only observed values, not guaranteed values.

$P_d = 2200mW$ (968mW): Substrate copper foil density 3%

$P_d = 3200mW$ (1408mW): Substrate copper foil density 34%

$P_d = 3500mW$ (1540mW): Substrate copper foil density 60% (Value within parentheses represents power dissipation when $T_a = 95^\circ C$)

(Note 3) Please preserve that the ambient temperature + self-generation of heat becomes 150°C or less because this IC has a $T_j = 150^\circ C$.

(Note 4) Please note the heat specification because there is a possibility that thermal resistance rises from the examination result of the temperature cycle by 20% or less.

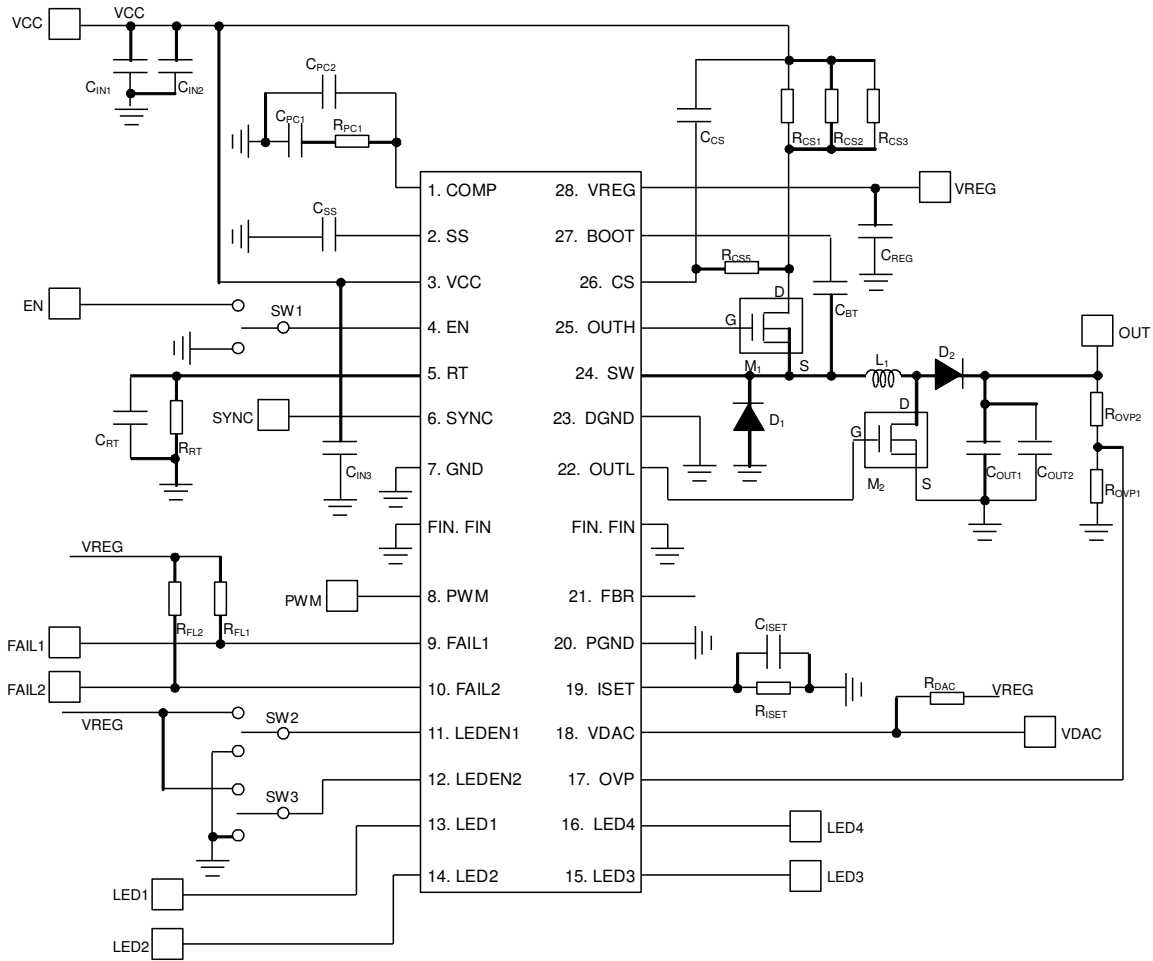

1. The coupling capacitors C_{VCC} and C_{REG} should be mounted as close as possible to the IC's pins.
2. Large currents may pass through DGND and PGND, so each should have its own low-impedance routing to the system ground.
3. Noise should be minimized as much as possible on pins VDAC, ISET, RT and COMP.
4. PWM, SYNC and LED1-4 carry switching signals, so ensure during layout that surrounding traces are not affected by crosstalk.

Application Board Part List

Serial No.	Component Name	Component Value	Product Name	Manufacturer
1	CIN1	10 μ F	GRM31CB31E106KA75B	Murata
2	CIN2	-		
3	CIN3	-		
4	CPC1	0.1 μ F		
5	CPC2	-		Murata
6	RPC1	510 Ω		
7	CSS	0.1 μ F	GRM188B31H104KA92	Murata
8	RRT	100k Ω	MCR03 Series	Rohm
9	CRT	-		
10	RFL1	100k Ω	MCR03 Series	Rohm
11	RFL2	100k Ω	MCR03 Series	Rohm
12	CCS	-		
13	RCS1	620m Ω	MCR100JZHFLR620	Rohm
14	RCS2	620m Ω	MCR100JZHFLR620	Rohm
15	RCS3	-		
16	RCS5	0 Ω		
17	CREG	2.2 μ F	GRM188B31A225KE33	Murata
18	CBT	0.1 μ F	GRM188B31H104KA92	Murata
19	M1	-	RSS070N05	Rohm
20	M2	-	RSS070N05	Rohm
21	D1	-	RB050L-40	Rohm
22	D2	-	RF201L2S	Rohm
23	L1	33 μ H	CDRH105R330	Sumida
24	COU1	10 μ F	GRM31CB31E106KA75B	Murata
25	COU2	10 μ F	GRM31CB31E106KA75B	Murata
26	ROVP1	30k Ω	MCR03 Series	Rohm
27	ROVP2	360k Ω	MCR03 Series	Rohm
28	RISSET	120k Ω	MCR03 Series	Rohm
29	CISSET	-		
30	RDAC	0 Ω		

1. The above values are fixed numbers for confirmed operation with the following conditions: $V_{CC} = 12V$, four parallel channels of five series-connected LEDs, and $I_{LED}=50mA$.
2. Optimal values of external components depend on the actual application; these values should only be used as guidelines and should be adjusted to fit the operating conditions of the actual application.

When performing open/short tests of the external components, the open condition of D_1 or D_2 may cause permanent damage to the driver and/or the external components. In order to prevent this, we recommend having parallel connections for D_1 and D_2 .

I/O Equivalent Circuits (terminal name follows pin number)

<p>1. COMP</p>	<p>2. SS</p>	<p>4. EN</p>
<p>5. RT</p>	<p>6. SYNC, 8. PWM</p>	<p>9. FAIL1, 10. FAIL2</p>
<p>11. LEDEN1, 12. LEDEN2</p>	<p>13. LED1, 14. LED2, 15. LED3, 16. LED4</p>	<p>17. OVP</p>
<p>18. VDAC</p>	<p>19. ISET</p>	<p>22. OUTL</p>
<p>24. SW</p>	<p>25. OUTH</p>	<p>26. CS</p>
<p>27. BOOT</p>	<p>28. VREG</p>	<p>21.</p> <p>N.C. = no connection (open)</p>

Operational Notes

1. Reverse Connection of Power Supply

Connecting the power supply in reverse polarity can damage the IC. Take precautions against reverse polarity when connecting the power supply, such as mounting an external diode between the power supply and the IC's power supply pins.

2. Power Supply Lines

Design the PCB layout pattern to provide low impedance supply lines. Separate the ground and supply lines of the digital and analog blocks to prevent noise in the ground and supply lines of the digital block from affecting the analog block. Furthermore, connect a capacitor to ground at all power supply pins. Consider the effect of temperature and aging on the capacitance value when using electrolytic capacitors.

3. Ground Voltage

Ensure that no pins are at a voltage below that of the ground pin at any time, even during transient condition.

4. Ground Wiring Pattern

When using both small-signal and large-current ground traces, the two ground traces should be routed separately but connected to a single ground at the reference point of the application board to avoid fluctuations in the small-signal ground caused by large currents. Also ensure that the ground traces of external components do not cause variations on the ground voltage. The ground lines must be as short and thick as possible to reduce line impedance.

5. Thermal Consideration

Should by any chance the power dissipation rating be exceeded the rise in temperature of the chip may result in deterioration of the properties of the chip. The absolute maximum rating of the Pd stated in this specification is when the IC is mounted on a 70mm x 70mm x 1.6mm glass epoxy board. In case of exceeding this absolute maximum rating, increase the board size and copper area to prevent exceeding the Pd rating.

6. Recommended Operating Conditions

These conditions represent a range within which the expected characteristics of the IC can be approximately obtained. The electrical characteristics are guaranteed under the conditions of each parameter.

7. Inrush Current

When power is first supplied to the IC, it is possible that the internal logic may be unstable and inrush current may flow instantaneously due to the internal powering sequence and delays, especially if the IC has more than one power supply. Therefore, give special consideration to power coupling capacitance, power wiring, width of ground wiring, and routing of connections.

8. Operation Under Strong Electromagnetic Field

Operating the IC in the presence of a strong electromagnetic field may cause the IC to malfunction.

9. Testing on Application Boards

When testing the IC on an application board, connecting a capacitor directly to a low-impedance output pin may subject the IC to stress. Always discharge capacitors completely after each process or step. The IC's power supply should always be turned off completely before connecting or removing it from the test setup during the inspection process. To prevent damage from static discharge, ground the IC during assembly and use similar precautions during transport and storage.

10. Inter-pin Short and Mounting Errors

Ensure that the direction and position are correct when mounting the IC on the PCB. Incorrect mounting may result in damaging the IC. Avoid nearby pins being shorted to each other especially to ground, power supply and output pin. Inter-pin shorts could be due to many reasons such as metal particles, water droplets (in very humid environment) and unintentional solder bridge deposited in between pins during assembly to name a few.

Operational Notes – continued

11. **Unused Input Pins**

Input pins of an IC are often connected to the gate of a MOS transistor. The gate has extremely high impedance and extremely low capacitance. If left unconnected, the electric field from the outside can easily charge it. The small charge acquired in this way is enough to produce a significant effect on the conduction through the transistor and cause unexpected operation of the IC. So unless otherwise specified, unused input pins should be connected to the power supply or ground line.

12. **Regarding the Input Pin of the IC**

This monolithic IC contains P+ isolation and P substrate layers between adjacent elements in order to keep them isolated. P-N junctions are formed at the intersection of the P layers with the N layers of other elements, creating a parasitic diode or transistor. For example (refer to figure below):

When GND > Pin A and GND > Pin B, the P-N junction operates as a parasitic diode.
 When GND > Pin B, the P-N junction operates as a parasitic transistor.

Parasitic diodes inevitably occur in the structure of the IC. The operation of parasitic diodes can result in mutual interference among circuits, operational faults, or physical damage. Therefore, conditions that cause these diodes to operate, such as applying a voltage lower than the GND voltage to an input pin (and thus to the P substrate) should be avoided.

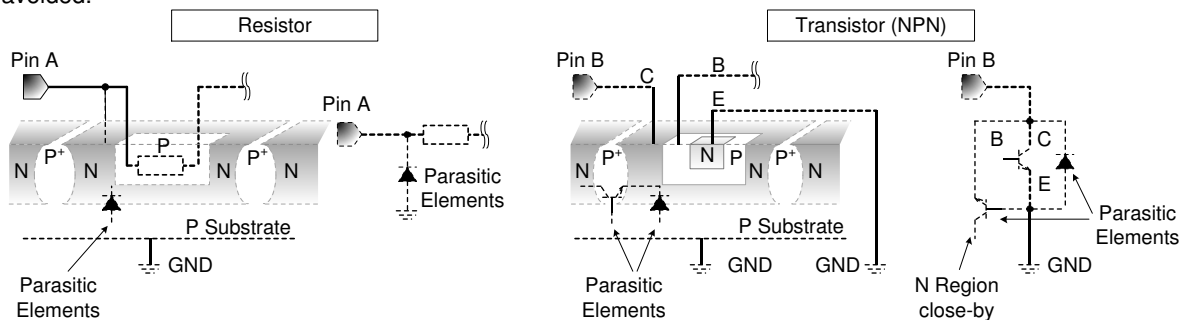

Figure 15. Example of monolithic IC structure

13. **Area of Safe Operation (ASO)**

Operate the IC such that the output voltage, output current, and power dissipation are all within the Area of Safe Operation (ASO).

14. **Thermal Shutdown Circuit(TSD)**

This IC has a built-in thermal shutdown circuit that prevents heat damage to the IC. Normal operation should always be within the IC's power dissipation rating. If however the rating is exceeded for a continued period, the junction temperature (Tj) will rise which will activate the TSD circuit that will turn OFF all output pins. When the Tj falls below the TSD threshold, the circuits are automatically restored to normal operation.

Note that the TSD circuit operates in a situation that exceeds the absolute maximum ratings and therefore, under no circumstances, should the TSD circuit be used in a set design or for any purpose other than protecting the IC from heat damage.

TSD ON temperature [°C] (typ)	Hysteresis temperature [°C] (typ)
175	25

Ordering Information

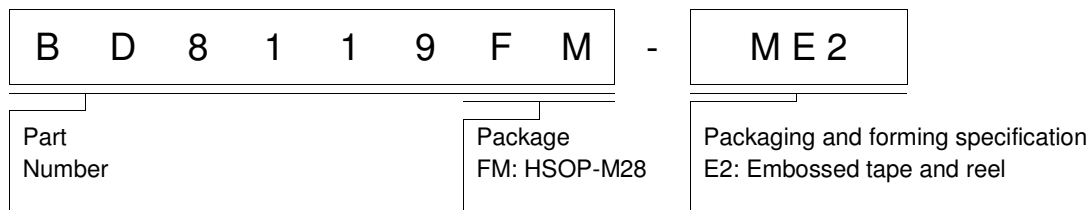

Marking Diagram

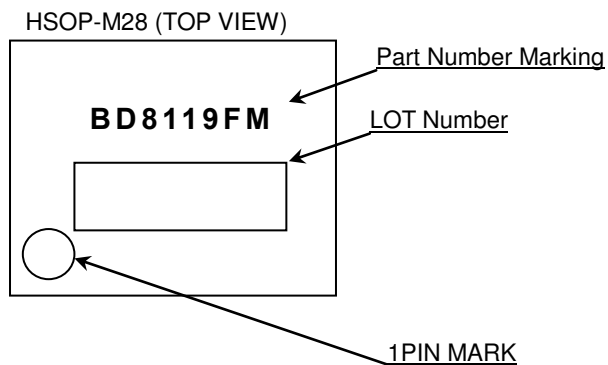

Part Number Marking	Package		Part Number
BD8119FM	HSOP-M28	Reel of 1500	BD8119FM – ME2

Physical Dimension, Tape and Reel Information

Package Name	HSOP-M28
--------------	----------

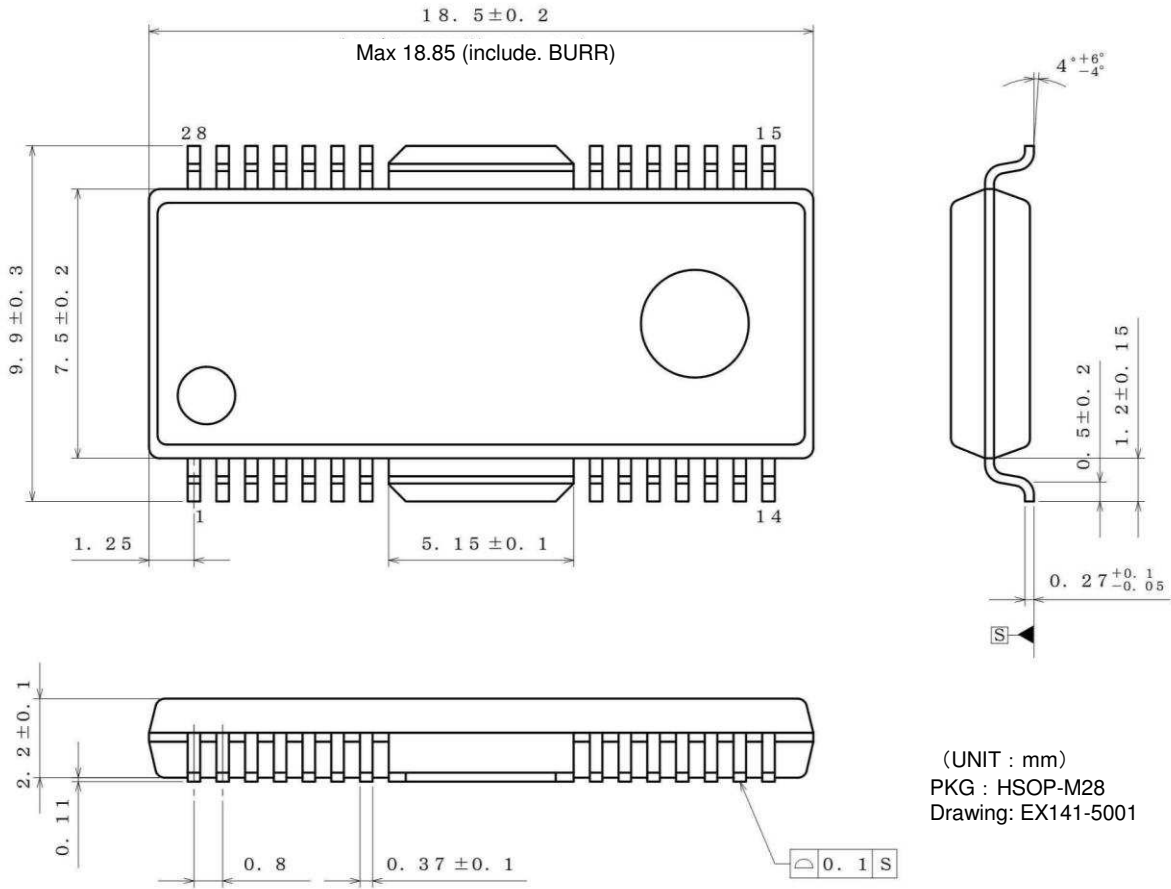

(UNIT : mm)
 PKG : HSOP-M28
 Drawing: EX141-5001

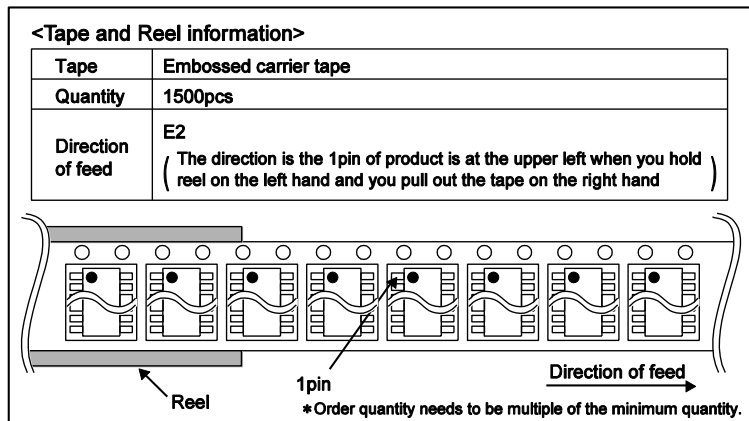

Revision History

Date	Revision	Changes
28.Aug.2014	001	New Release

Notice

Precaution on using ROHM Products

1. If you intend to use our Products in devices requiring extremely high reliability (such as medical equipment ^(Note 1), aircraft/spacecraft, nuclear power controllers, etc.) and whose malfunction or failure may cause loss of human life, bodily injury or serious damage to property ("Specific Applications"), please consult with the ROHM sales representative in advance. Unless otherwise agreed in writing by ROHM in advance, ROHM shall not be in any way responsible or liable for any damages, expenses or losses incurred by you or third parties arising from the use of any ROHM's Products for Specific Applications.

(Note1) Medical Equipment Classification of the Specific Applications

JAPAN	USA	EU	CHINA
CLASS III	CLASS III	CLASS II b	CLASS III
CLASS IV		CLASS III	

2. ROHM designs and manufactures its Products subject to strict quality control system. However, semiconductor products can fail or malfunction at a certain rate. Please be sure to implement, at your own responsibilities, adequate safety measures including but not limited to fail-safe design against the physical injury, damage to any property, which a failure or malfunction of our Products may cause. The following are examples of safety measures:
 - [a] Installation of protection circuits or other protective devices to improve system safety
 - [b] Installation of redundant circuits to reduce the impact of single or multiple circuit failure
3. Our Products are not designed under any special or extraordinary environments or conditions, as exemplified below. Accordingly, ROHM shall not be in any way responsible or liable for any damages, expenses or losses arising from the use of any ROHM's Products under any special or extraordinary environments or conditions. If you intend to use our Products under any special or extraordinary environments or conditions (as exemplified below), your independent verification and confirmation of product performance, reliability, etc, prior to use, must be necessary:
 - [a] Use of our Products in any types of liquid, including water, oils, chemicals, and organic solvents
 - [b] Use of our Products outdoors or in places where the Products are exposed to direct sunlight or dust
 - [c] Use of our Products in places where the Products are exposed to sea wind or corrosive gases, including Cl₂, H₂S, NH₃, SO₂, and NO₂
 - [d] Use of our Products in places where the Products are exposed to static electricity or electromagnetic waves
 - [e] Use of our Products in proximity to heat-producing components, plastic cords, or other flammable items
 - [f] Sealing or coating our Products with resin or other coating materials
 - [g] Use of our Products without cleaning residue of flux (even if you use no-clean type fluxes, cleaning residue of flux is recommended); or Washing our Products by using water or water-soluble cleaning agents for cleaning residue after soldering
 - [h] Use of the Products in places subject to dew condensation
4. The Products are not subject to radiation-proof design.
5. Please verify and confirm characteristics of the final or mounted products in using the Products.
6. In particular, if a transient load (a large amount of load applied in a short period of time, such as pulse. is applied, confirmation of performance characteristics after on-board mounting is strongly recommended. Avoid applying power exceeding normal rated power; exceeding the power rating under steady-state loading condition may negatively affect product performance and reliability.
7. De-rate Power Dissipation (Pd) depending on Ambient temperature (Ta). When used in sealed area, confirm the actual ambient temperature.
8. Confirm that operation temperature is within the specified range described in the product specification.
9. ROHM shall not be in any way responsible or liable for failure induced under deviant condition from what is defined in this document.

Precaution for Mounting / Circuit board design

1. When a highly active halogenous (chlorine, bromine, etc.) flux is used, the residue of flux may negatively affect product performance and reliability.
2. In principle, the reflow soldering method must be used; if flow soldering method is preferred, please consult with the ROHM representative in advance.

For details, please refer to ROHM Mounting specification

Precautions Regarding Application Examples and External Circuits

1. If change is made to the constant of an external circuit, please allow a sufficient margin considering variations of the characteristics of the Products and external components, including transient characteristics, as well as static characteristics.
2. You agree that application notes, reference designs, and associated data and information contained in this document are presented only as guidance for Products use. Therefore, in case you use such information, you are solely responsible for it and you must exercise your own independent verification and judgment in the use of such information contained in this document. ROHM shall not be in any way responsible or liable for any damages, expenses or losses incurred by you or third parties arising from the use of such information.

Precaution for Electrostatic

This Product is electrostatic sensitive product, which may be damaged due to electrostatic discharge. Please take proper caution in your manufacturing process and storage so that voltage exceeding the Products maximum rating will not be applied to Products. Please take special care under dry condition (e.g. Grounding of human body / equipment / solder iron, isolation from charged objects, setting of Ionizer, friction prevention and temperature / humidity control).

Precaution for Storage / Transportation

1. Product performance and soldered connections may deteriorate if the Products are stored in the places where:
 - [a] the Products are exposed to sea winds or corrosive gases, including Cl₂, H₂S, NH₃, SO₂, and NO₂
 - [b] the temperature or humidity exceeds those recommended by ROHM
 - [c] the Products are exposed to direct sunshine or condensation
 - [d] the Products are exposed to high Electrostatic
2. Even under ROHM recommended storage condition, solderability of products out of recommended storage time period may be degraded. It is strongly recommended to confirm solderability before using Products of which storage time is exceeding the recommended storage time period.
3. Store / transport cartons in the correct direction, which is indicated on a carton with a symbol. Otherwise bent leads may occur due to excessive stress applied when dropping of a carton.
4. Use Products within the specified time after opening a humidity barrier bag. Baking is required before using Products of which storage time is exceeding the recommended storage time period.

Precaution for Product Label

QR code printed on ROHM Products label is for ROHM's internal use only.

Precaution for Disposition

When disposing Products please dispose them properly using an authorized industry waste company.

Precaution for Foreign Exchange and Foreign Trade act

Since our Products might fall under controlled goods prescribed by the applicable foreign exchange and foreign trade act, please consult with ROHM representative in case of export.

Precaution Regarding Intellectual Property Rights

1. All information and data including but not limited to application example contained in this document is for reference only. ROHM does not warrant that foregoing information or data will not infringe any intellectual property rights or any other rights of any third party regarding such information or data. ROHM shall not be in any way responsible or liable for infringement of any intellectual property rights or other damages arising from use of such information or data.:
2. No license, expressly or implied, is granted hereby under any intellectual property rights or other rights of ROHM or any third parties with respect to the information contained in this document.

Other Precaution

1. This document may not be reprinted or reproduced, in whole or in part, without prior written consent of ROHM.
2. The Products may not be disassembled, converted, modified, reproduced or otherwise changed without prior written consent of ROHM.
3. In no event shall you use in any way whatsoever the Products and the related technical information contained in the Products or this document for any military purposes, including but not limited to, the development of mass-destruction weapons.
4. The proper names of companies or products described in this document are trademarks or registered trademarks of ROHM, its affiliated companies or third parties.

General Precaution

1. Before you use our Products, you are requested to carefully read this document and fully understand its contents. ROHM shall not be in any way responsible or liable for failure, malfunction or accident arising from the use of any ROHM's Products against warning, caution or note contained in this document.
2. All information contained in this document is current as of the issuing date and subject to change without any prior notice. Before purchasing or using ROHM's Products, please confirm the latest information with a ROHM sales representative.
3. The information contained in this document is provided on an "as is" basis and ROHM does not warrant that all information contained in this document is accurate and/or error-free. ROHM shall not be in any way responsible or liable for any damages, expenses or losses incurred by you or third parties resulting from inaccuracy or errors of or concerning such information.