



Optical Sensor Product Data Sheet LTR-329ALS-01

Spec No.: DS86-2014-0006

Effective Date: 09/04/2014

Revision: B

LITE-ON DCC

RELEASE

BNS-OD-FC001/A4

Optical Sensor LTR-329ALS-01

1. Description

The LTR-329ALS-01 is a low voltage I2C digital light sensor [ALS] in a low cost miniature chip lead-free surface mount package. This sensor converts light intensity to a digital output signal capable of direct I²C interface. It provides a linear response over a wide dynamic range from 0.01 lux to 64k lux and is well suited to applications under high ambient brightness. There are altogether six gain settings (1X, 2X, 4X, 8X, 48X and 96X) available for user to configure.

This CMOS design and factory-set one time trimming capability ensure minimal sensor-to-sensor variations for ease of manufacturability to the end customers.

2. Features

- I2C interface (Fast Mode @ 400kbit/s)
- Ultra-small ChipLED package
- Built-in temperature compensation circuit
- Low active power consumption with standby mode
- Supply voltage range from 2.4V to 3.6V capable of 1.7V logic voltage
- Operating temperature range from -30 °C to +70 °C
- RoHS and Halogen free compliant
- Light Sensor
 - Close to human eye spectral response
 - Immunity to IR / UV Light Source
 - Automatically rejects 50 / 60 Hz lightings flicker
 - 6 dynamic range from 0.01 lux to 64k lux
 - 16-bit effective resolution

3. Applications

To control display backlight in

- Mobile Devices: Mobile phone, PDA
- Computing Devices: Notebook PC, Desktop Monitor
- Consumer Devices: LCD/PDP TV backlight systems, Cameras, Personal Navigation Device, Digital Photo Frame
- Dashboard

Optical Sensor LTR-329ALS-01

4. Ordering Information

Part Number	Packaging Type	Package	Quantity
LTR-329ALS-01	Tape and Reel	4-pins chipped package	2500

5. Outline Dimensions

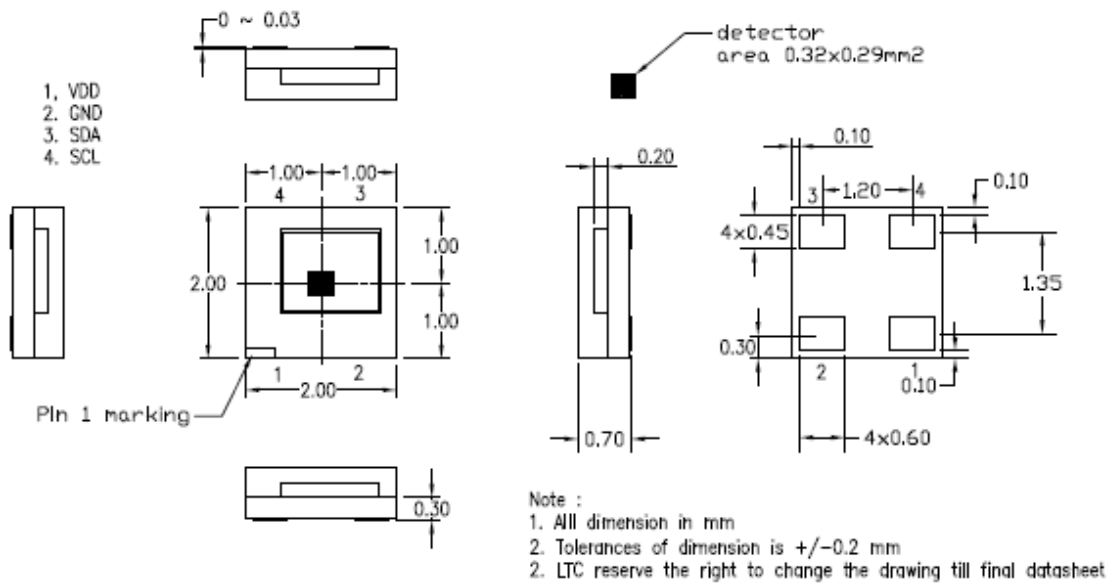

Notes :

- All dimensions are in millimeters.

Optical Sensor LTR-329ALS-01

6. Functional Block Diagram

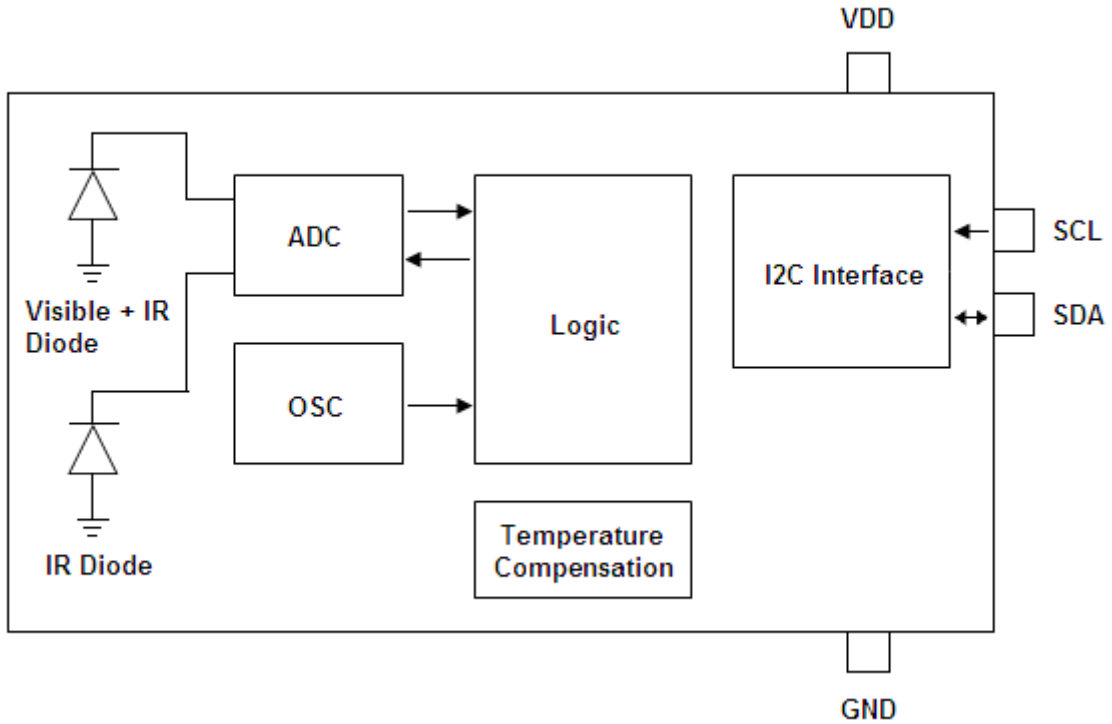

7. Application Circuit

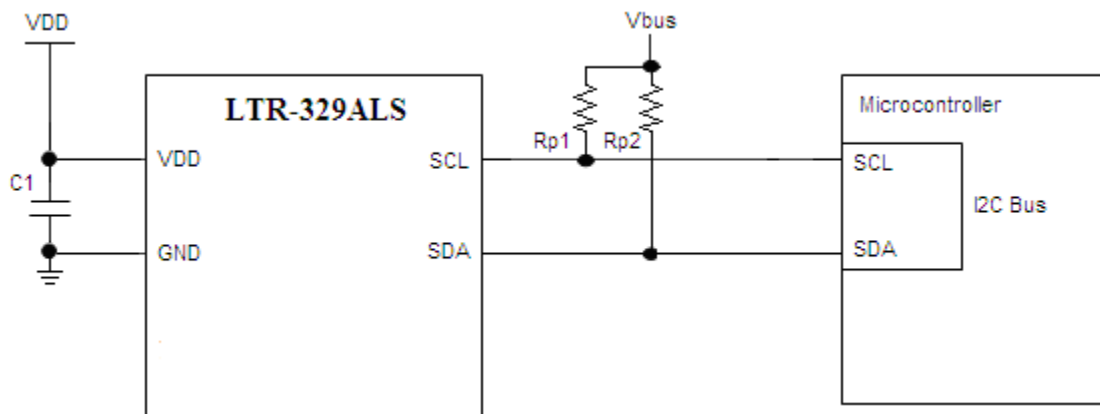

Optical Sensor LTR-329ALS-01

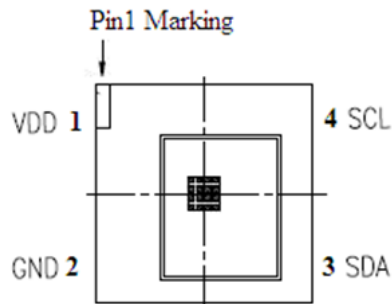

I/O Pins Configuration Table

Pin	I/O Type	Symbol	Description
1		VDD	Power Supply Voltage
2		GND	Ground
3	I/O	SDA	I ² C serial data. This pin is an open drain input / output.
4	I	SCL	I ² C serial clock. This pin is an open drain input.

Recommended Application Circuit Components

Component	Recommended Value
Rp1, Rp2, Rp3 [1]	1 k Ω to 10 k Ω
C1, C2	1 μ F \pm 20%, X7R Ceramic

Optical Sensor LTR-329ALS-01

8. Ratings and Specifications

Absolute Maximum Ratings at Ta = 25°C

Parameter	Symbol	Rating	Unit
Supply Voltage	VDD	3.8	V
Digital Voltage Range	SCL, SDA, INT	-0.5 to 3.8	V
Digital Output Current	SCL, SDA, INT	-1 to 20	mA
Storage Temperature	T _{stg}	-40 to 100	°C

Note: Exceeding these ratings could cause damage to the sensor. All voltages are with respect to ground. Currents are positive into, negative out of the specified terminal.

Recommended Operating Conditions

Description	Symbol	Min.	Typ.	Max.	Unit
Supply Voltage	VDD	2.4		3.6	V
LED Supply Voltage	VLED	2.5		4.35	V
Interface Bus Power Supply Voltage	V _{IO}	1.7		3.6	V
Operating Temperature	T _{ope}	-30		70	°C

Electrical & Optical Specifications

All specifications are at VDD = 3.0V, T_{ope} = 25°C, unless otherwise noted.

Parameter	Min.	Typ.	Max.	Unit	Condition
Active Supply Current			250	uA	Active Mode, T _{ope} = 25°C
Standby Current			5	uA	Standby / Sleep Mode
Initial Startup Time	60	100	1000	ms	(Note 1)
Wakeup Time from Standby			10	ms	(Note 1)

Optical Sensor LTR-329ALS-01

Light Sensor

Parameter	Min.	Typ.	Max.	Unit	Condition
Full Scale ADC Count			65535	count	Full Scale ADC Count
Dark ADC Count	0		6	count	Ch0, Lux = 0
	0		6	count	Ch1, Lux = 0
ADC Count (Gain=96)	830		1550	count	Ch0, Lux = 200 (White LED)
	3250		6100	count	Ch1, Lux = 200 (White LED)
					Integration Time : 50ms
					Measurement Time : 100ms
ALS Ratio	0.15		0.35	Ratio	Ratio = Ch1/(Ch1 + Ch0), Lux = 200 (White LED)

Typical Performance Curve

All specifications are at VDD = 3.0V, T_{ope} = 25°C, unless otherwise noted.

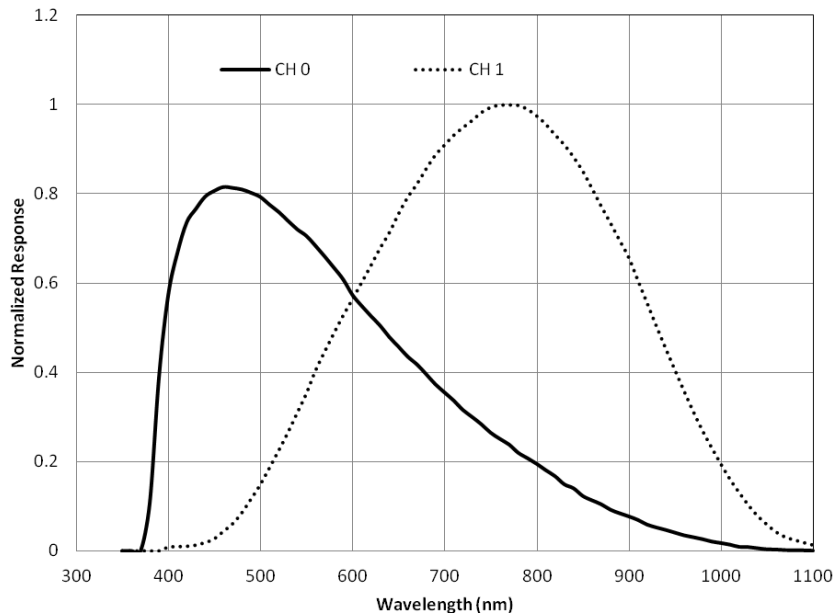

Figure 1: Normalized Spectral Response

**Optical Sensor
LTR-329ALS-01**

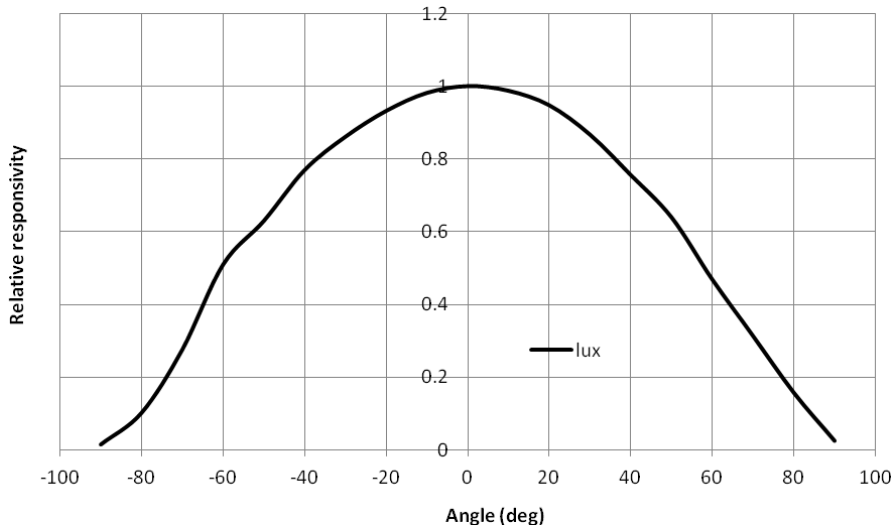

Figure 2 : Viewing angle

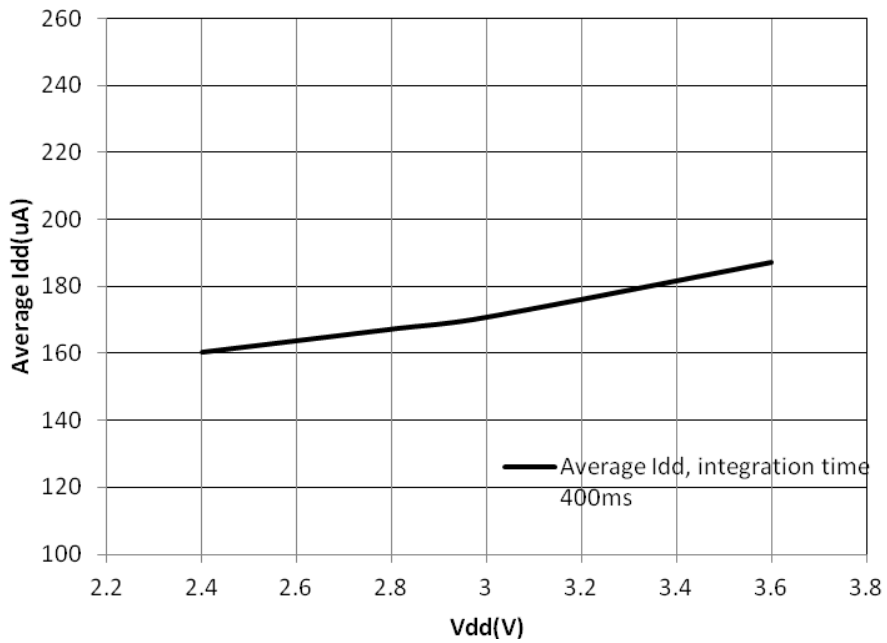

Figure 3 : Vdd versus Average Idd

**Optical Sensor
LTR-329ALS-01**

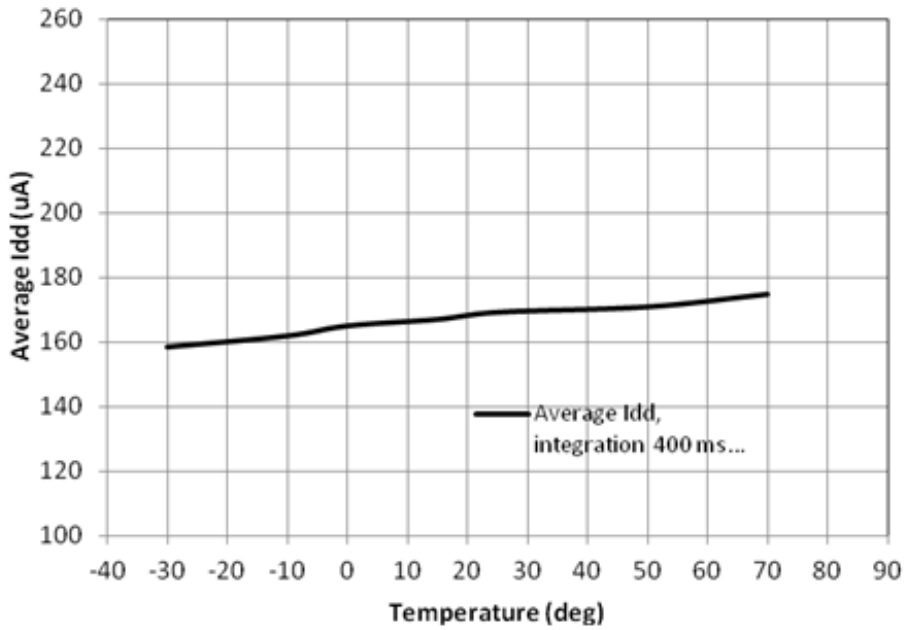

Figure 4 : Average Idd versus temperature

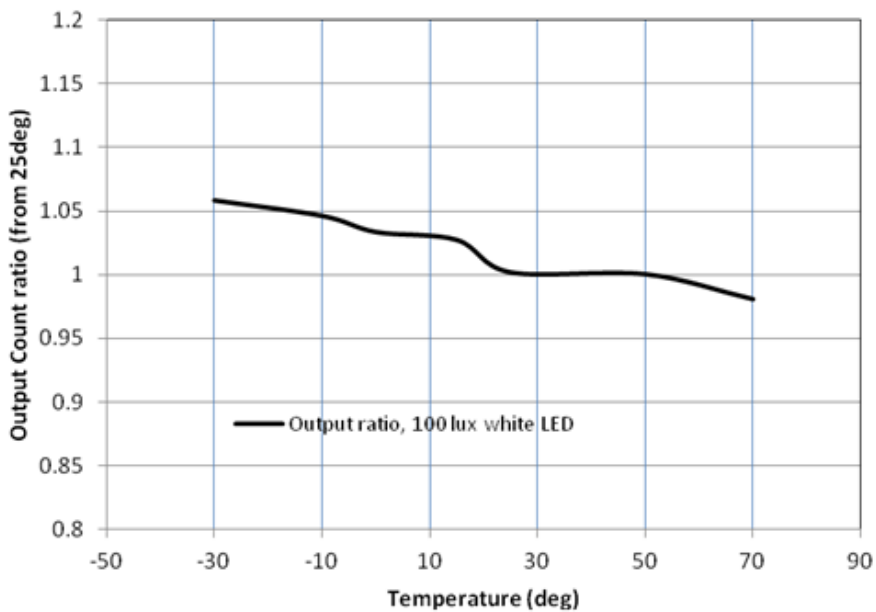

Figure 5 : Output count ratio versus temperature

Optical Sensor LTR-329ALS-01

Lux Formula

Refer to Appendix A for the lux formula

Notes:

1. Startup Sequence

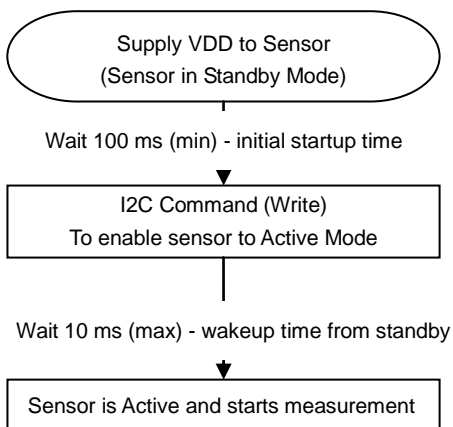

Optical Sensor LTR-329ALS-01

AC Electrical Characteristics

All specifications are at $V_{Bus} = 1.8V$, $T_{ope} = 25^{\circ}C$, unless otherwise noted.

Parameter	Symbol	Min.	Max.	Unit
SCL clock frequency	f_{SCL}	1	400	kHz
Bus free time between a STOP and START condition	t_{BUF}	1.3		us
Hold time (repeated) START condition. After this period, the first clock pulse is generated	$t_{HD;STA}$	0.6		us
LOW period of the SCL clock	t_{LOW}	1.3		us
HIGH period of the SCL clock	t_{HIGH}	0.6		us
Set-up time for a repeated START condition	$t_{SU;STA}$	0.6		us
Set-up time for STOP condition	$t_{SU;STO}$	0.6		us
Rise time of both SDA and SCL signals	t_r	30	300	ns
Fall time of both SDA and SCL signals	t_f	30	300	ns
Data hold time	$t_{HD;DAT}$	0.3	0.9	us
Data setup time	$t_{SU;DAT}$	100		ns
Pulse width of spikes which must be suppressed by the input filter	t_{SP}	0	50	ns

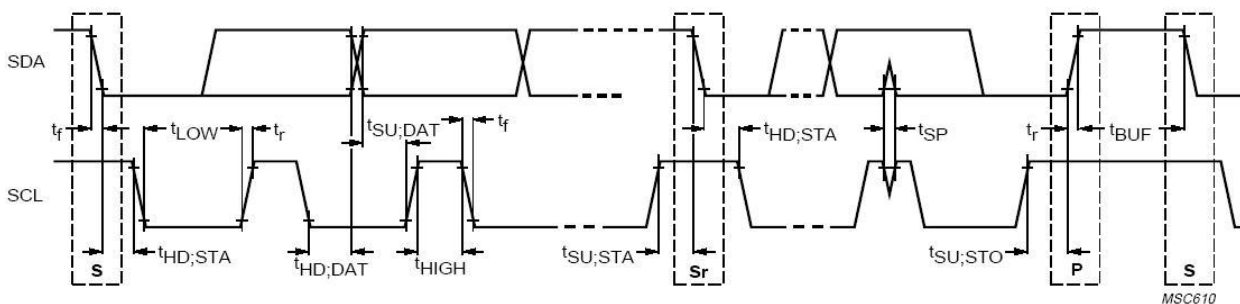

Definition of timing for I²C bus

9. Principles of Operation

I²C Protocols

• I²C Write Protocol (type 1):

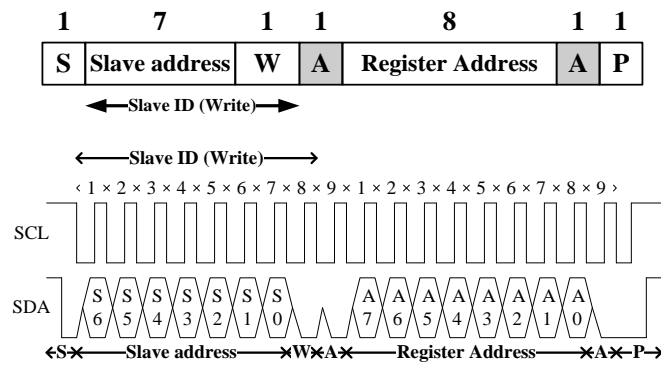

• I²C Write Protocol (type 2):

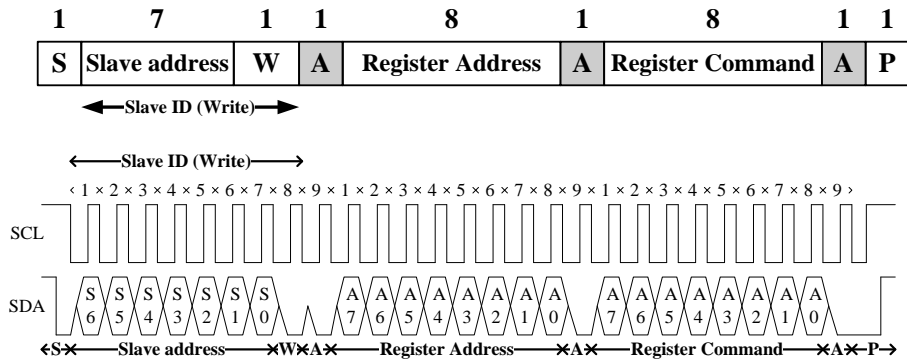

• I²C Read Protocol:

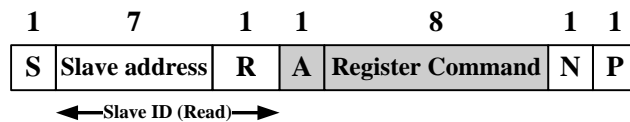

Optical Sensor LTR-329ALS-01

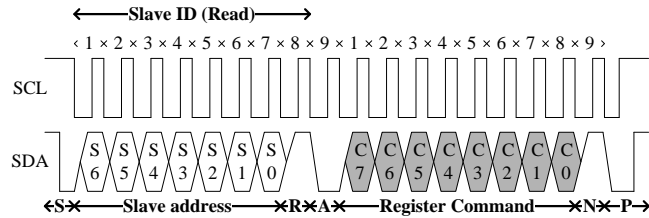

· I²C Read (Combined format) Protocol:

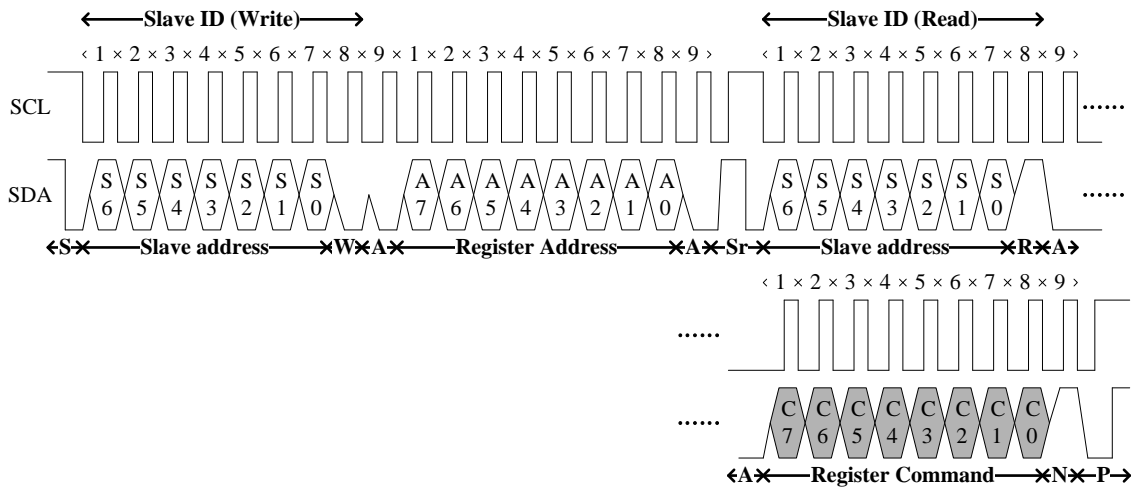
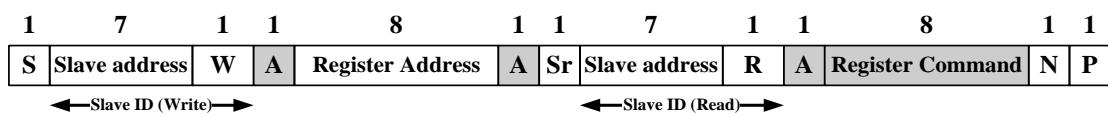

- | | |
|--|--|
| <p>A Acknowledge (0 for an ACK)</p> <p>S Start condition</p> <p>P Stop condition</p> <p>W Write (0 for writing)</p> <p> Slave-to-master</p> | <p>N Non-Acknowledge(1 for an NACK)</p> <p>Sr Repeated Start condition</p> <p>R Read (1 for read)</p> <p> Master-to-Slave</p> |
|--|--|

I²C Slave Address

The 7 bits slave address for this sensor is 0x29H. A read/write bit should be appended to the slave address by the master device to properly communicate with the sensor.

Optical Sensor LTR-329ALS-01

I ² C Slave Address									
Command Type	(0x29H)							W/R	value
	Bit7	Bit6	Bit5	Bit4	Bit3	Bit2	Bit1	Bit0	
Write	0	1	0	1	0	0	1	0	0x52H
Read	0	1	0	1	0	0	1	1	0x53H

Register Set

Addr	R / W	Register Name	Description	Reset Value
0x80	R / W	ALS_CONTR	ALS operation mode control SW reset	0x00
0x85	R / W	ALS_MEAS_RATE	ALS measurement rate in active mode	0x03
0x86	R	PART_ID	Part Number ID and Revision ID	0xA0
0x87	R	MANUFAC_ID	Manufacturer ID	0x05
0x88	R	ALS_DATA_CH1_0	ALS measurement CH1 data, lower byte	0x00
0x89	R	ALS_DATA_CH1_1	ALS measurement CH1 data, upper byte	0x00
0x8A	R	ALS_DATA_CH0_0	ALS measurement CH0 data, lower byte	0x00
0x8B	R	ALS_DATA_CH0_1	ALS measurement CH0 data, upper byte	0x00
0x8C	R	ALS_STATUS	ALS new data status	0x00

Notes:

- 1) *When reading ALS data registers, read sequence should always be from lower address to higher address (E.g. For ALS data, Ch1 data should be read first followed by Ch0 data. Read sequence should be 0x88, 0x89, 0x8A, 0x8B. When 0x8B is read, all four ALS data registers will be populated with new set of data).*

Optical Sensor LTR-329ALS-01

ALS_CONTR Register (0x80)

The ALS_CONTR register controls the ALS Gain setting, ALS operation modes and software (SW) reset for the sensor. The ALS sensor can be set to either standby mode or active mode. At either of these modes, the I²C circuitry is always active. The default mode after power up is standby mode. During standby mode, there is no ALS measurement performed but I²C communication is allowed to enable read/write to all the registers

0x80	ALS_CONTR (default = 0x00)							
	B7	B6	B5	B4	B3	B2	B1	B0
	Reserved			ALS Gain			SW Reset	ALS Mode

Field	Bits	Default	Type	Description	
Reserved	7:5	000	--	--	
ALS Gain	4:2	000	RW	000	Gain 1X → 1 lux to 64k lux (default)
				001	Gain 2X → 0.5 lux to 32k lux
				010	Gain 4X → 0.25 lux to 16k lux
				011	Gain 8X → 0.125 lux to 8k lux
				100	Reserved
				101	Reserved
				110	Gain 48X → 0.02 lux to 1.3k lux
				111	Gain 96X → 0.01 lux to 600 lux
SW reset	1	0	RW	0	Initial start-up procedure is NOT started (default)
				1	Initial start-up procedure is started, bit has default value of 0 after start-up
ALS mode	0	0	RW	0	Stand-by mode (default)
				1	Active mode

Optical Sensor LTR-329ALS-01

ALS_MEAS_RATE Register (0x85)

The ALS_MEAS_RATE register controls the integration time and timing of the periodic measurement of the ALS in active mode. ALS Measurement Repeat Rate is the interval between ALS_DATA registers update. ALS Integration Time is the measurement time for each ALS cycle. ALS Integration Time must be set to be equal or smaller than the ALS Measurement Repeat Rate. If ALS Integration Time is set to be bigger than ALS Measurement Repeat Rate, it will be automatically reset to be equal to ALS Measurement Repeat Rate by the IC internally.

0x85	ALS_MEAS_RATE (default = 0x03)							
	B7	B6	B5	B4	B3	B2	B1	B0
	<i>Reserved</i>		<i>ALS Integration Time</i>			<i>ALS Measurement Repeat Rate</i>		

Field	Bits	Default	Type	Description	
Reserved	7:6	00	--	--	--
ALS integration time	5:3	000	RW	000	100ms (default)
				001	50ms
				010	200ms
				011	400ms
				100	150ms
				101	250ms
				110	300ms
				111	350ms
ALS measurement rate	2:0	011	RW	000	50ms
				001	100ms
				010	200ms
				011	500ms (default)
				100	1000ms
				101	2000ms
				110	
				111	

Optical Sensor LTR-329ALS-01

PART_ID Register (0x86) (Read Only)

The PART_ID register defines the part number and revision identification of the sensor.

0x86	PART_ID (default = 0x92)							
	B7	B6	B5	B4	B3	B2	B1	B0
	<i>Part Number ID</i>				<i>Revision ID</i>			

Field	Bits	Default	Type	Description
Part Number ID	7:4	1010	R	Part ID 0x0AH
Revision ID	3:0	0000	R	Revision ID 0x00H

MANUFAC_ID Register (0x87) (Read Only)

The MANUFAC_ID register defines the manufacturer identification of the sensor.

0x87	MANUFAC_ID (default = 0x05)							
	B7	B6	B5	B4	B3	B2	B1	B0
	<i>Manufacturer ID</i>							

Field	Bits	Default	Type	Description
Manufacturer ID	7:0	00000101	R	Manufacturer ID (0x05H)

Optical Sensor LTR-329ALS-01

ALS_DATA_CH1 Register (0x88 / 0x89) (Read Only)

The ALS_DATA registers should be read as a group, with the lower address read back first (i.e. read 0x88 first, then read 0x89). These two registers should also be read before reading channel-0 data (from registers 0x8A, 0x8B). When the I²C read operation starts, all four ALS data registers are locked until the I²C read operation of register 0x8B is completed. This will ensure that the data in the registers is from the same measurement even if an additional integration cycle ends during the read operation. New measurement data is stored into temporary registers and the ALS_DATA registers are updated as soon as there is no on-going I²C read operation. The ALS ADC channel-1 data is expressed as a 16-bit data spread over two registers. The ALS_DATA_CH1_0 and ALS_DATA_CH1_1 registers provide the lower and upper byte respectively.

0x88	ALS_DATA_CH1_0 (default = 0x00)							
	B7	B6	B5	B4	B3	B2	B1	B0
	<i>ALS Data Ch1 Low</i>							

0x89	ALS_DATA_CH1_1 (default = 0x00)							
	B7	B6	B5	B4	B3	B2	B1	B0
	<i>ALS Data Ch1 High</i>							

Field	Address	Bits	Default	Type	Description
ALS Data Ch1 Low	0x88	7:0	00000000	R	ALS ADC channel 1 lower byte data
ALS Data Ch1 High	0x89	7:0	00000000	R	ALS ADC channel 1 upper byte data

Optical Sensor LTR-329ALS-01

ALS_DATA_CH0 Register (0x8A / 0x8B) (Read Only)

These two registers should be read after reading channel-1 data (from registers 0x88, 0x89). Lower address register should be read first (i.e read 0x8A first, then read 0x8B). See ALS_DATA_CH1 register information above. The ALS ADC channel-0 data is expressed as a 16-bit data spread over two registers. The ALS_DATA_CH0_0 and ALS_DATA_CH0_1 registers provide the lower and upper byte respectively.

0x8A	ALS_DATA_CH0_0 (default = 0x00)							
	B7	B6	B5	B4	B3	B2	B1	B0
	<i>ALS Data Ch0 Low</i>							

0x8B	ALS_DATA_CH0_1 (default = 0x00)							
	B7	B6	B5	B4	B3	B2	B1	B0
	<i>ALS Data Ch0 High</i>							

Field	Address	Bits	Default	Type	Description
ALS Data Ch0 Low	0x8A	7:0	00000000	R	ALS ADC channel 0 lower byte data
ALS Data Ch0 High	0x8B	7:0	00000000	R	ALS ADC channel 0 upper byte data

ALS_STATUS Register (0x8C) (Read Only)

The ALS_STATUS register stores the information about ALS data status. New data means data has not been read yet. When the measurement is completed and data is written to the data register, the data status bit will be set to logic 1. When the data register is read, the data status bit will be set to logic 0.

Optical Sensor LTR-329ALS-01

0x8C	ALS_PS_STATUS (default = 0x00)							
	B7	B6	B5	B4	B3	B2	B1	B0
	<i>ALS Data Valid</i>	<i>ALS Gain</i>			<i>ALS Interrupt Status</i>	<i>ALS Data Status</i>	<i>Reserved</i>	

Field	Bits	Default	Type	Description	
ALS Data Valid	7	0	R	0	ALS Data is Valid (default)
				1	ALS Data is Invalid
ALS Data Gain Range	6:4	000	R	000	ALS measured data in Gain 1X (default)
				001	ALS measured data in Gain 2X
				010	ALS measured data in Gain 4X
				011	ALS measured data in Gain 8X
				100	Invalid
				101	Invalid
				110	ALS measured data in Gain 48X
111	ALS measured data in Gain 96X				
Reserved	3	0	R	0	Don't care
ALS data status	2	0	R	0	OLD data (data already read), (default)
				1	NEW data (first time data is being read)
Reserved	1:0	00	R	--	Don't care

10. Device Operation(using Interrupt)

Below flow diagram illustrates the LTR-329ALS operation.

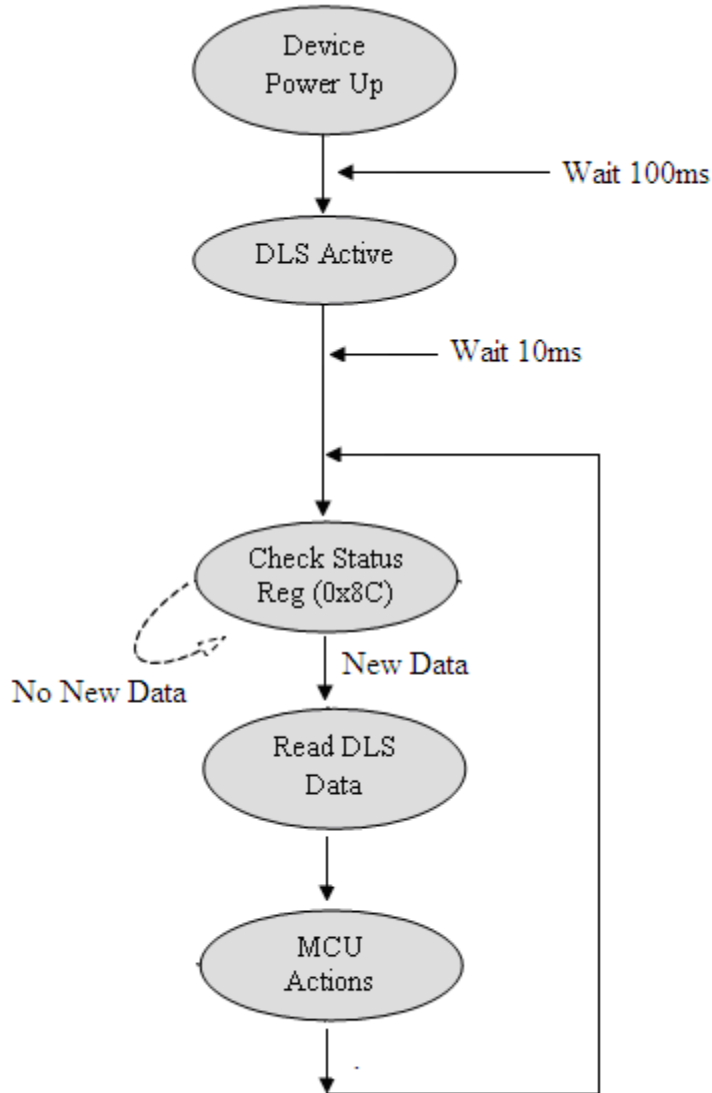

Optical Sensor LTR-329ALS-01

11. Pseudo Codes Examples

Control Registers

// The Control Register defines the operating modes and gain settings of the ALS of LTR-329.
// Default settings is 0x00 (in Standby mode).

Slave_Addr = 0x29 // Slave address of LTR-329 device

// Enable ALS

Register_Addr = 0x80 // ALS_CONTR register
Command = 0x01 // For Gain X1
// For Gain X96, Command = 0x1D

WriteByte(Slave_Addr, Register_Addr, Command)

ALS Measurement Rate

// The ALS_MEAS_RATE register controls the ALS integration time and measurement rate.
// Default setting of the register is 0x03 (integration time 100ms, repeat rate 500ms)

Slave_Addr = 0x29 // Slave address of LTR-329 device

// Set ALS Integration Time 200ms, Repeat Rate 200ms

Register_Addr = 0x85 // ALS_MEAS_RATE register
Command = 0x12 // Int time = 200ms, Meas rate = 200ms
// For Int time = 400ms, Meas rate = 500ms, Command = 0x1B

WriteByte(Slave_Addr, Register_Addr, Command)

ALS Data Registers (Read Only)

// The ALS Data Registers contain the ADC output data for the respective channel.
// These registers should be read as a group, with the lower address being read first.

Slave_Addr = 0x29 // Slave address of LTR-329 device

// Read back ALS_DATA_CH1

Register_Addr = 0x88 // ALS_DATA_CH1 low byte address
ReadByte(Slave_Addr, Register_Addr, Data0)
Register_Addr = 0x89 // ALS_DATA_CH1 high byte address
ReadByte(Slave_Addr, Register_Addr, Data1)

// Read back ALS_DATA_CH0

Register_Addr = 0x8A // ALS_DATA_CH0 low byte address
ReadByte(Slave_Addr, Register_Addr, Data2)
Register_Addr = 0x8B // ALS_DATA_CH0 high byte address
ReadByte(Slave_Addr, Register_Addr, Data3)

ALS_CH1_ADC_Data = (Data1 << 8) | Data0 // Combining lower and upper bytes to give 16-bit Ch1 data

ALS_CH0_ADC_Data = (Data3 << 8) | Data2 // Combining lower and upper bytes to give 16-bit Ch0 data

Optical Sensor LTR-329ALS-01

ALS Status Register (Read only)

// The ALS_STATUS Register contains the information on ALS data availability status.
// This register is read only.

Slave_Addr = 0x29 // Slave address of LTR-329 device

// Read back Register

Register_Addr = 0x8C // ALS_STATUS register address
ReadByte(Slave_Addr, Register_Addr, Data)

NewData_Status = Data & 0x04

// NewData_Status = 4(decimal) → ALS New Data
// ALS_Data_Valid = 0x00 → ALS New Data is valid (usable)
// ALS_Data_Valid = 0x80 → ALS New Data is invalid, discard and wait for
new ALS data

**Optical Sensor
LTR-329ALS-01**

12. Recommended Leadfree Reflow Profile

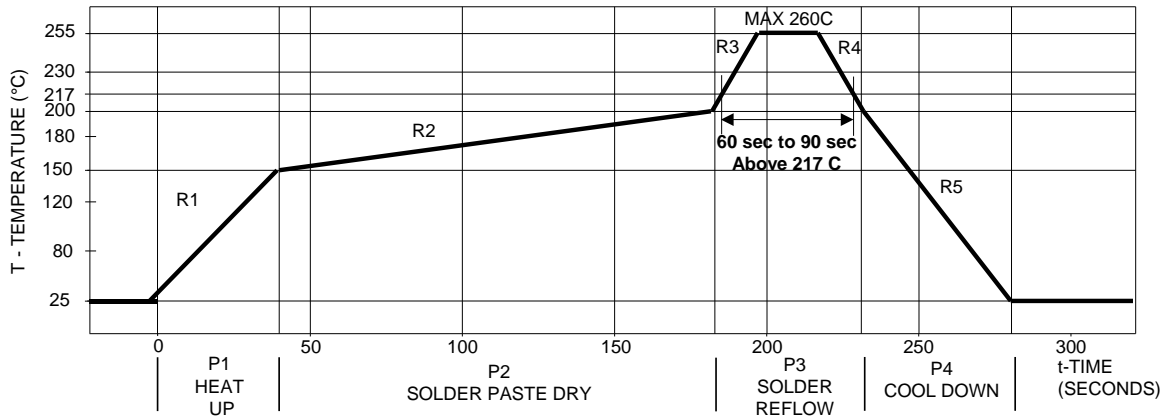

Process Zone	Symbol	ΔT	Maximum $\Delta T/\Delta$ time or Duration
Heat Up	P1, R1	25°C to 150°C	3°C/s
Solder Paste Dry	P2, R2	150°C to 200°C	100s to 180s
Solder Reflow	P3, R3	200°C to 260°C	3°C/s
	P3, R4	260°C to 200°C	-6°C/s
Cool Down	P4, R5	200°C to 25°C	-6°C/s
Time maintained above liquidus point , 217°C		> 217°C	60s to 90s
Peak Temperature		260°C	-
Time within 5°C of actual Peak Temperature		> 255°C	20s
Time 25°C to Peak Temperature		25°C to 260°C	8mins

It is recommended to perform reflow soldering no more than twice.

**Optical Sensor
LTR-329ALS-01**

13. Moisture Proof Packaging

All LTR-329ALS-01 are shipped in moisture proof package. Once opened, moisture absorption begins. This part is compliant to JEDEC J-STD-033A Level 3.

Time from Unsealing to Soldering

After removal from the moisture barrier bag, the parts should be stored at the recommended storage conditions and soldered within seven days. When the moisture barrier bag is opened and the parts are exposed to the recommended storage conditions for more than seven days, the parts must be baked before reflow to prevent damage to the parts.

Recommended Storage Conditions

Storage Temperature	10°C to 30°C
Relative Humidity	Below 60% RH

Baking Conditions

Package	Temperature	Time
In Reels	60°C	48 hours
In Bulk	100°C	4 hours

Baking should only be done once.

**Optical Sensor
LTR-329ALS-01**

14. Recommended Land Pattern and Metal Stencil Aperture

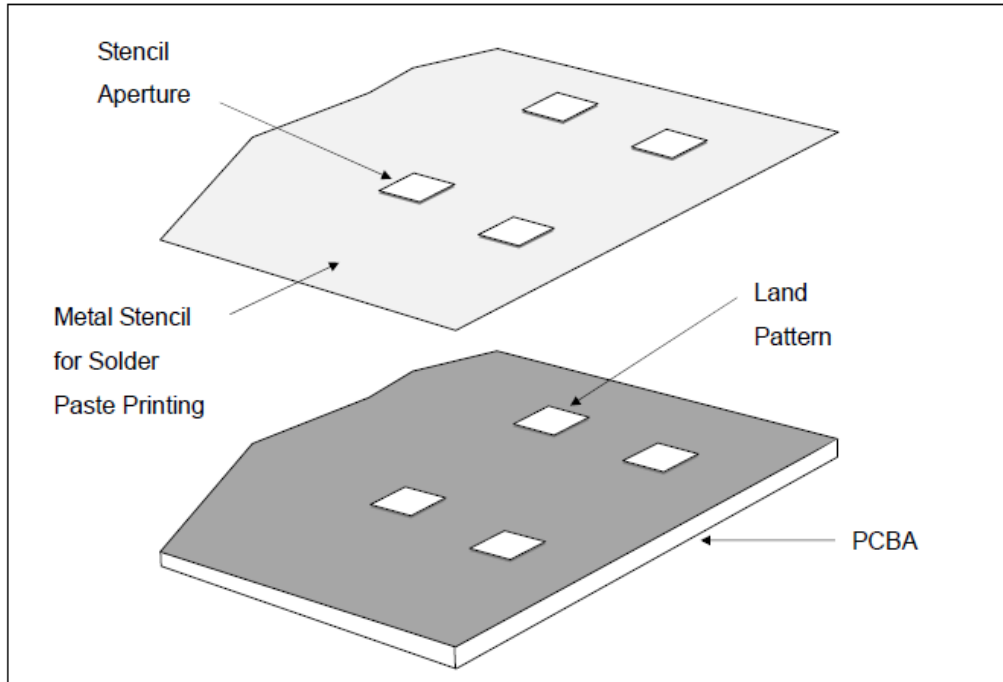

Recommended Land Pattern

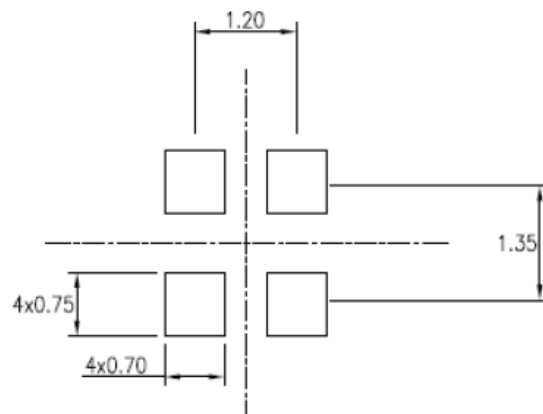

Note:

1. All dimensions are in millimeters

Optical Sensor LTR-329ALS-01

Recommended Metal Stencil Aperture

It is recommended that the metal stencil used for solder paste printing has a thickness (t) of 0.11mm (0.004 inches / 4 mils) or 0.127mm (0.005 inches / 5 mils).

The stencil aperture opening is recommended to be 0.72mm x 0.60mm which has the same dimension as the land pattern. This is to ensure adequate printed solder paste volume and yet no shorting.

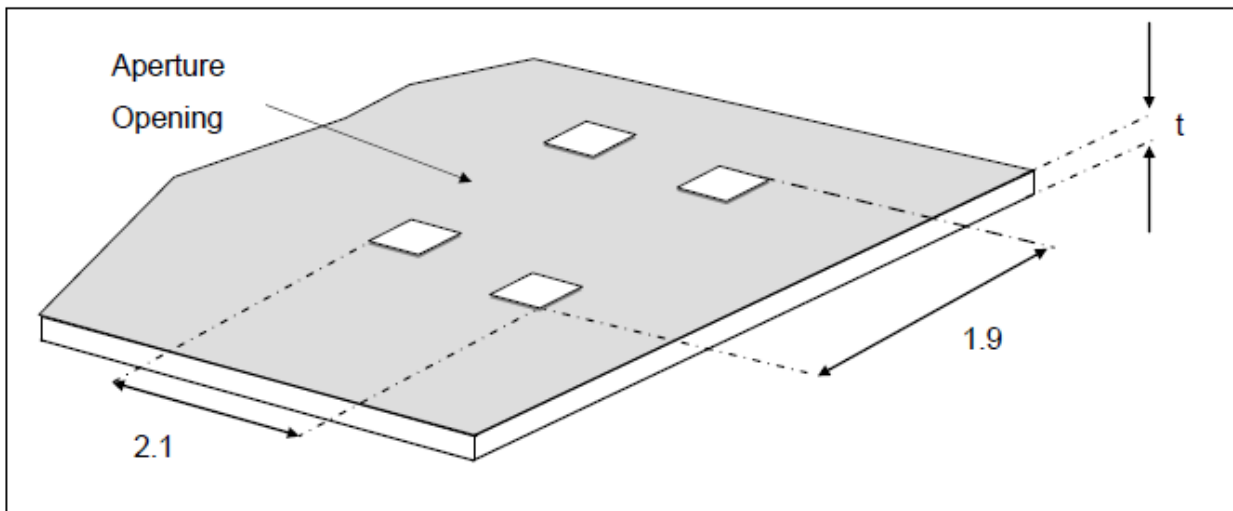

Note:

1. All dimensions are in millimeters

Optical Sensor LTR-329ALS-01

15. Package Dimension for Tape and Reel

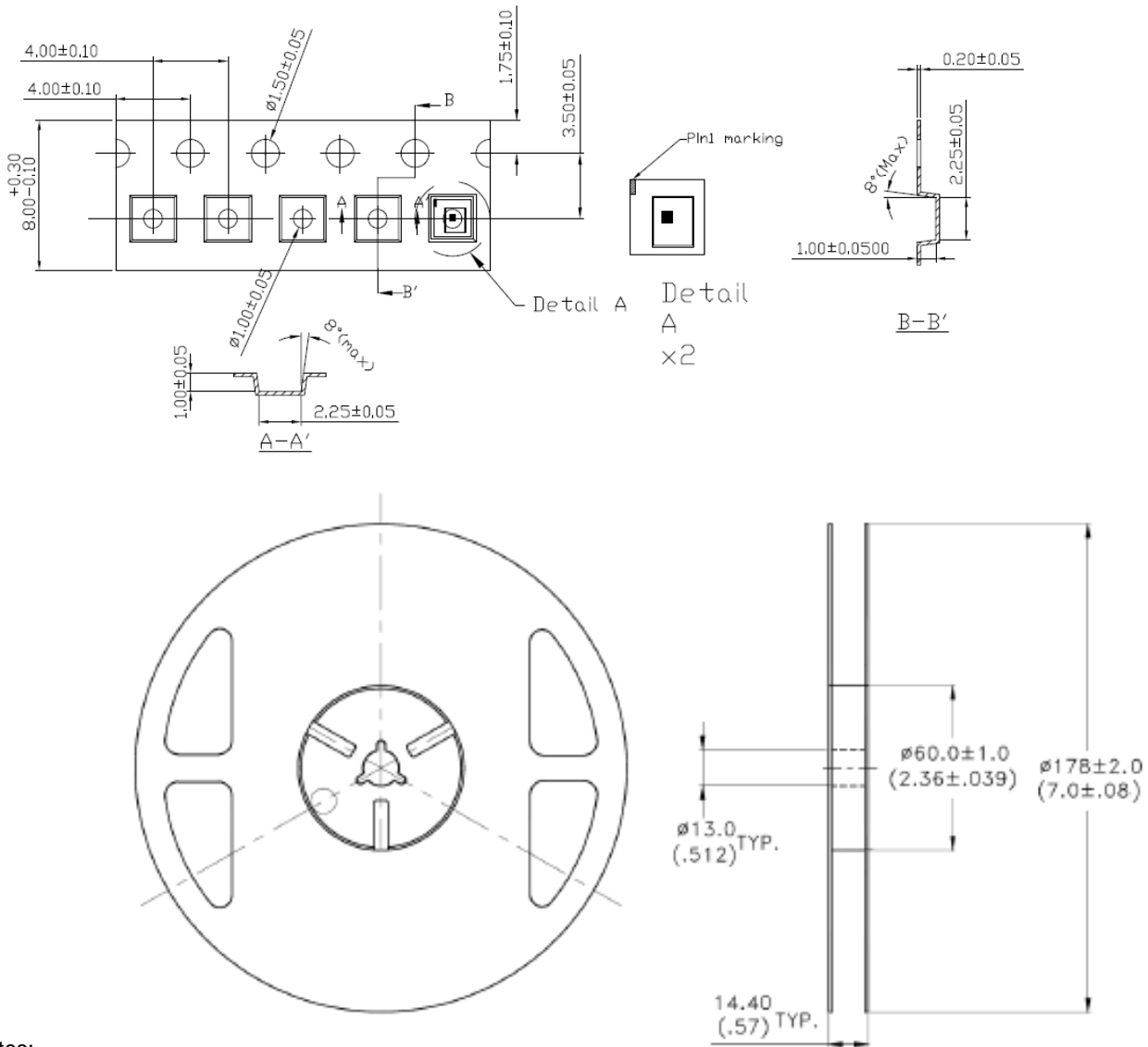

Notes:

1. All dimensions are in millimeters (inches)
2. Empty component pockets sealed with top cover tape
3. 7 inch reel - 2500 pieces per reel
4. In accordance with ANSI/EIA 481-1-A-1994 specifications.