

Super-Regeneration RF Receiver

W55RFS27R1B

Data Sheet

Contents

General Description	3
1.1 W55RFS27R1B Features	3
1.2 W55RFS27R1B Pad Definition	4
1.2.1 Pad Description	4
1.2.2 Mode selection	5
System Description	6
2.1 W55RFS27R1B System Block Diagram	6
2.2 W55RFS27R1B Functional Description	7
Electronic Characteristics	7
3.1 W55RFS27R1B Absolute Maximum Ratings	7
3.2 W55RFS27R1B DC Characteristics	8
3.3 W55RFS27R1B Ordering Information	8
3.4 W55RFS27R1B Package Information	9
3.4.1 W55RFS27R1B Bonding Pad List	9
3.4.2 W55RFS27R1B Bonding Pad Diagram	10
Design Information	11
4.1 W55RFS27R1B Reference Design	11
4.1.1 W55RFS27R1B Application Circuit	11
4.2 W55RFS27R1B <i>Smart-Detector^{WB}</i> Function	12
4.2.1 Introduction	12
4.2.2 Using <i>Smart-Detector^{WB}</i> in <i>Manual-mode</i>	12
4.2.3 Using <i>Smart-Detector^{WB}</i> in <i>uC-mode</i>	13
4.3 W55RFS27R1B Layout Guide	13
4.4 W55RFS27R1B Data Sheet Document History	14

General Description

nuvoTon W55RFS27R1B is a fully integrated S-R (Super-regenerative) RF receiver with full-function of baseband control command decoder for application of R/C vehicle, toy, or wireless data communication.

W55RFS27R1B provides both *uC-mode* for general purpose micro-controller programming interface and *manual-mode* for RF receiver with on-chip 6-function baseband command decoder.

W55RFS27R1B provides *Smart-Detector^{WB}* function which overcomes component deviation, maintain the best receiver sensitivity in mass-production. *Smart-Detector^{WB}* is also capable of adjusting itself to fit various kinds of

environmental problems. Some factors like temperature, moisture, or object caused antenna characteristic change could be recovered by the *Smart-Detector^{WB}* function.

The Super-Regenerative RF front-end architecture is convenient for 27MHz ~ 49MHz manufacturing with minimum external components. With wide range of operating voltage 2.1V ~ 5.5V, W55RFS27R1B is suitable for remote controlled toy on 2-battery or 3-battery application.

W55RFS27R1B cooperate with W55RFS27T1B is easy and convenient to provide simple remote control function with long control distance and low production cost.

1.1 W55RFS27R1B Features

- ❑ Operating frequency: 27MHz,35MHz, 40MHz, 49MHz
 - ❑ **Smart-Detector^{WB}** function overcomes the components deviation and environmental problem and maintain best sensitivity in mass-production and operation
 - ❑ Operating voltage: 2.1V ~ 5.5V
 - ❑ S-R (Super-regeneration) demodulation scheme
 - ❑ Receiving data rates up to 1.25Kbps for 50% duty cycle
 - ❑ **Manual-mode** supports 6-function baseband decoder, i.e, Forward, Backward, Left-turn, right-turn, and 2 user defined function F1 and F2
 - ❑ Minimization of current consumption in system
 - ❑ Very low power down current consumption (*uC-mode* only)
 - ❑ Less manual adjustment needed in production
 - ❑ Fewer external components required in production
 - ❑ Lower manufacture production cost
 - ❑ Dice form available for PCB bonding
 - ❑ Operating temperature: 0°C ~ 70°C
-

1.2 W55RFS27R1B Pad Definition

1.2.1 Pad Description

Symbol	Pad No.	I/O	Functional Description
GND	1	Ground	Ground return path
CMFB	2	O	Common-mode feedback capacitor connect
RBIAS	3	I	Resistor to adjust internal circuit bias
RSAW	4	O	Resistor to control internal saw generator
VDDA	5	Power	Regulated voltage output
OSCI _n	6	I	Oscillator tank input
OSCO _u	7	O	Oscillator tank output
GND _A	8	Ground	Regulator ground return path
Reset	9	I	Reset=0 resets whole chip, internally pull-high
Mode0	10	I	Mode select LSB, please see 1.2.2 for detail
Mode1	11	I	Mode select MSB, please see 1.2.2 for detail
TEST	12	I	TEST=1 reserved for chip testing, must be set "0" when operating.
F2	13	O/I	Decoder F2 output / uC-mode = \$ENB ("0" power down)*
F1	14	O/I	Decoder F1 output / uC-mode = Not used (Set "0" in uC-mode)*
R	15	O/I	Decoder Right-turn output / uC-mode = \$HOPCLK (Set "0" in uC-mode)*
L	16	O/I	Decoder Left-turn output / uC-mode = \$OAGC2 (Set "0" in uC-mode)*
B	17	O/I	Decoder Backward output / uC-mode = \$OAGC1 (Set "1" in uC-mode)*
F	18	O/I	Decoder Forward output / uC-mode = \$OAGC0 (Set "0" in uC-mode)*
RXD	19	O/I	Receiver data output
VSPLY	20	Power	Power input

(* uC-mode control please refer to sec.4.2 *Smart-Detector^{WB}* Function)

1.2.2 Mode selection

(MODE1,MODE0)	Function Description	Note
(0,0)	Disable <i>Smart-Detector^{WB}</i> Function	Function evaluation only
(0,1)	<i>uC-mode</i> , <i>Smart-Detector^{WB}</i> Function is external controlled	Baseband decoder is disabled in this mode
(1,0)	Enable half of <i>Smart-Detector^{WB}</i> function OAGC OFF , HOPPING ON	Function evaluation only
(1,1)	Enable <i>Smart-Detector^{WB}</i> function OAGC ON, HOPPING ON	Suitable for mass-production

System Description

2.1 W55RFS27R1B System Block Diagram

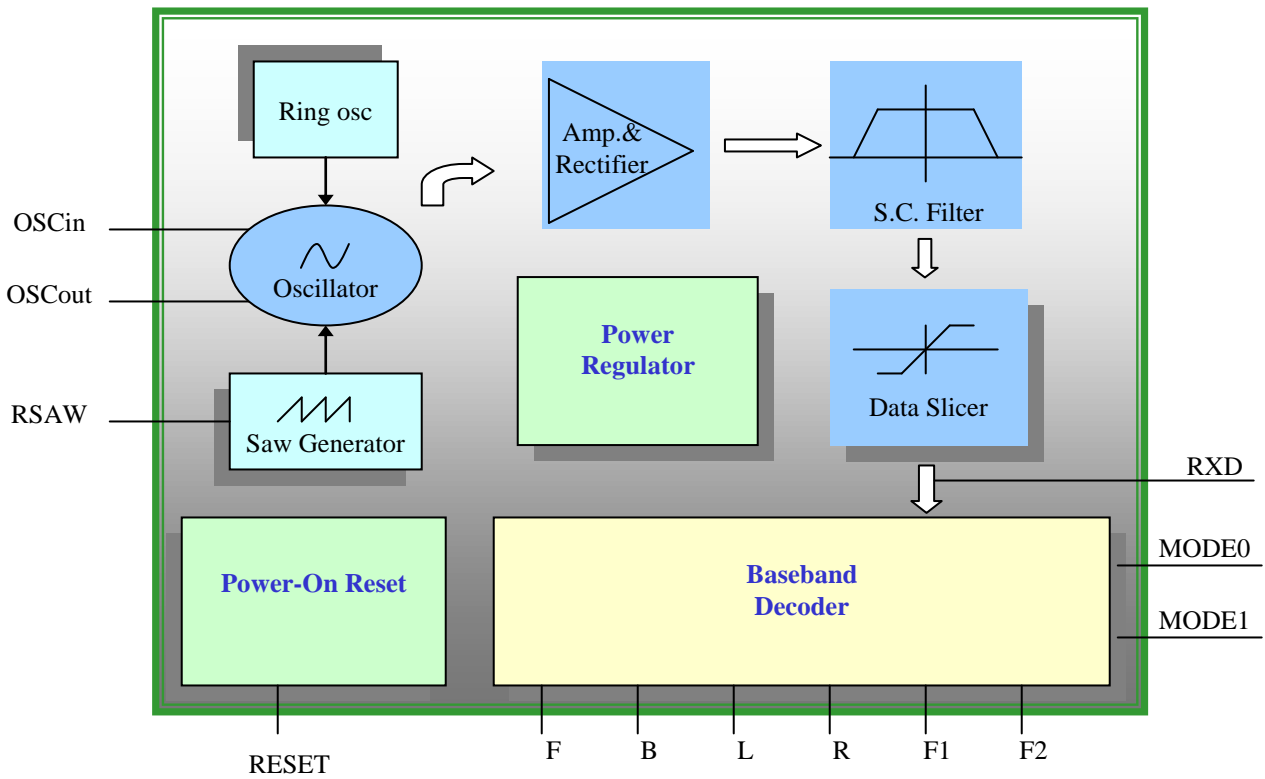

2.2 W55RFS27R1B Functional Description

Power Regulator

W55RFS27R1B build-in on chip power regulator provides a stable operating performance under operating voltage from 2.1V ~ 5.5V, the very wide range of operating voltage is suitable for mini R/C toy or R/C vehicle application. Especially for 2-battery or 3-battery .

RF Receiver

W55RFS27R1B has been implemented by using "Super-Regenerative" receiving architecture for R/C toy application. The high noise immunity structure is very suitable for getting higher RF

receiving performance in very high noise level environment. The **Smart-Detector^{WB}** function overcomes component deviation and various environmental problems, maintain the best receiver sensitivity in mass-production and operation.

Baseband Control Function Decoder

W55RFS27R1B build-in 6-function of general R/C toy baseband control function for R/C toy "Forward"; "Backward"; "Left-turn"; "Right-turn", and 2 more reserved control functions of "F1"; "F2".

Electronic Characteristics

3.1 W55RFS27R1B Absolute Maximum Ratings

Parameter	Rating	Unit
Supply Voltage to Ground Potential	- 0.3 to 6.5	V
Applied Input/Output Voltage	- 0.3 to 6.5	V
Power Dissipation (T _a = 70°C)	150	mW
Ambient Operating Temperature	0 to 70	°C
Storage Temperature	-40 to 85	°C

Note: Exposure to conditions beyond those listed under Absolute Maximum Ratings may adversely affect the life and reliability of the device.

3.2 W55RFS27R1B DC Characteristics

(VDD-VSS = 3 V, Ta = 25°C; unless otherwise specified)

Parameter	Sym.	Conditions	Min.	Typ.	Max.	Unit
Power Supply						
Operating Voltage	V _{DD}		2.1	-	5.5	V
Operating Current	I _{OP}		-	-	2.8	mA
Stand-by Current	I _{SBY}	\$ENB= 0	-	-	2	μA
Regulated Voltage	V _{DDA}		1.65	1.8	2.1	V
Digital Input/Output Pin						
Input High Voltage	V _{IH}		0.8*V _{DD}	-	V _{DD}	V
Input Low Voltage	V _{IL}		V _{SS}	-	0.1*V _{DD}	V
F,B,L,R,F1,F2 Output High Source	I _{OH}	V _{OH} =0.7 * V _{DD}	6	-	-	mA
F,B,L,R,F1,F2 Output Low Sink	I _{OL}	V _{OL} =0.3 * V _{DD}	6	-	-	mA
RXD Output High Source Current	I _{OH}	V _{OH} =0.7 * V _{DD}	2	-	-	mA
RXD Output Low Sink Current	I _{OL}	V _{OL} =0.3 * V _{DD}	2	-	-	mA
Crystal Oscillator						
Operation Frequency	F _C		27	-	49.8	MHz
On-chip Ring Oscillator frequency	T _{OSC}		170	200	250	KHz
Baseband Decoder Section						
Modulation Duty Cycle	M _{DYT}		40	50	60	%
Received Data Rate	R _{DTT}	50% Duty-cycle Manchester Code	-	1.25	-	Kbps

3.3 W55RFS27R1B Ordering Information

Part Number	Package	Remarks
W55RFS27R1B(H)	Dice form	
W55RFS27R1B(W)	Wafer form	

W55RFS27R1B provides two types in shipment: Dice form, and wafer form

3.4 W55RFS27R1B Package Information

3.4.1 W55RFS27R1B Bonding Pad List

 Window : (xl = -929.000, yl = -625.000),
 (xh = 929.000, yh = 625.000)
 Windows size : Width = 1858.000, length = 1250.000

=====
 ===

PAD NO	PAD NAME	PIN NAME	X	Y
1	* GND	* 1	-13.000	540.000
2	CMFB	2	-365.950	540.000
3	RBIAS	3	-472.950	540.000
4	RS AW	4	-579.950	540.000
5	VDDA	5	-689.350	540.000
6	VDDA	5	-801.150	540.000
7	OSCin	6	-795.075	-540.000
8	OS Cout	7	-667.875	-540.000
9	GNDA	8	-555.150	-540.000
10	reset	9	-128.675	-540.000
11	MODE0	10	-21.675	-540.000
12	MODE1	11	85.325	-540.000
13	TEST	12	192.325	-540.000
14	F2	13	302.925	-540.000
15	F1	14	790.325	540.000
16	R	15	675.875	540.000
17	L	16	561.425	540.000
18	B	17	446.975	540.000
19	F	18	332.525	540.000
20	RXD	19	218.075	540.000
21	VSPLY	20	98.400	540.000

(*: Bonding Sequence start from GND(Pin1))

3.4.2 W55RFS27R1B Bonding Pad Diagram

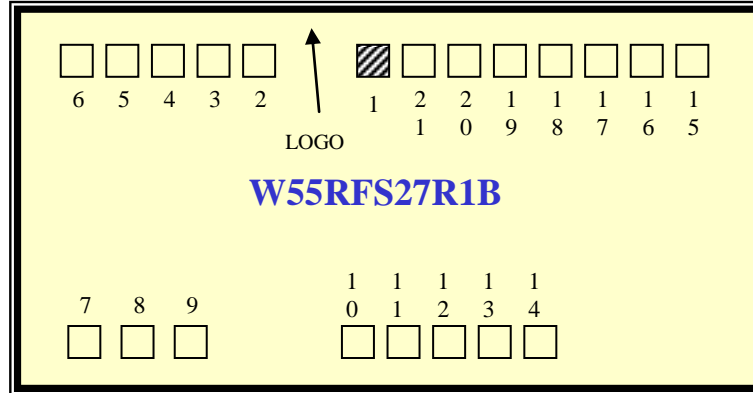

Design Information

4.1 W55RFS27R1B Reference Design

4.1.1 W55RFS27R1B Application Circuit

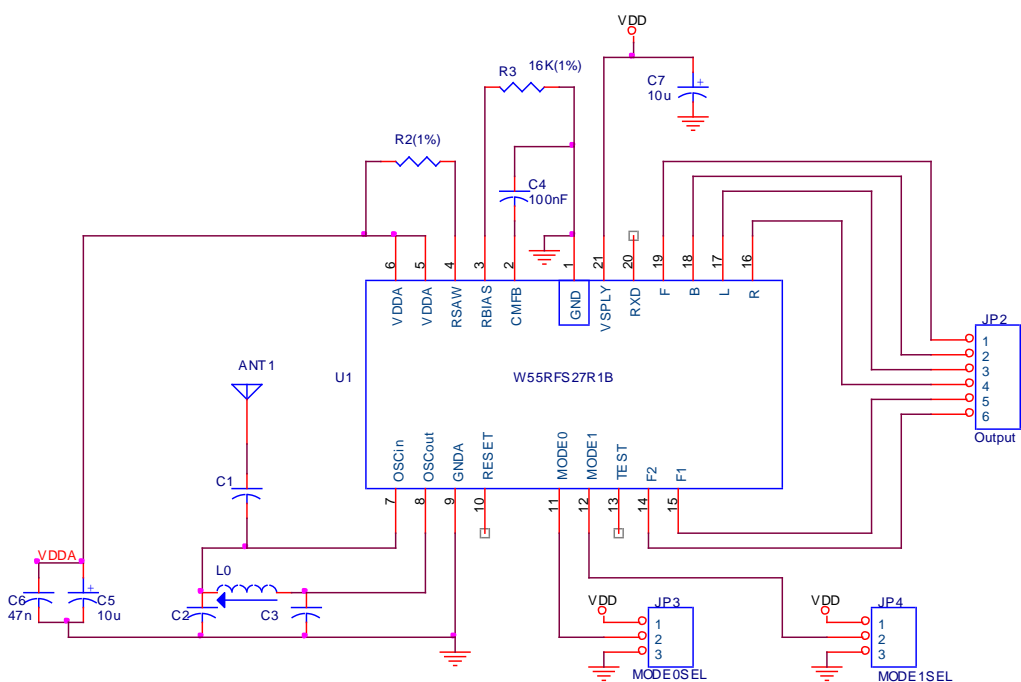

27MHz: C1=15pF, C2=27pF, C3=27pF, L0=1.5uH, R2=36K
 35MHz: C1=10pF, C2=24pF, C3=24pF, L0=1.2uH, R2=39K
 40MHz: C1= 7pF, C2=16pF, C3=18pF, L0=.82uH, R2=51K
 49MHz: C1= 4pF, C2=16pF, C3=18pF, L0=.82uH, R2=47K

Size	Document Number	Rev
A	W55RFS27R1B Application Circuit	A1
Date:	Wednesday, May 19, 2004	Sheet 1 of 1

(* Note: The components value is suitable for 15cm antenna. RSAW(R2) may need modified for different antenna.)

W55RFS27R1B Application Schematic BOM:

Item	Qty	Reference	Part
1	1	ANT1	ANTENNA
2	1	C1	4pF
3	1	C2	16P
4	1	C3	18P
5	1	C4	100nF
6	2	C7,C5	10u
7	1	C6	47n
8	1	JP2	Output
9	1	JP3	MODE0SEL
10	1	JP4	MODE1SEL
11	1	L0	0.82u
12	1	R2	47K(1%)
13	1	R3	16K(1%)
14	1	U1	W55RFS27R1B

4.2 W55RFS27R1B *Smart-Detector*^{WB} Function

4.2.1 Introduction

Smart-Detector Function enables on-chip OAGC(Oscillator Auto-Gain-Control) and Hopping clock function, is designed for recovery of components deviation and environment change. It dynamically searches the best operating condition and maintains best sensitivity in various environments.

The control mechanism is built with the communication protocol of W55RFS27T1BW55RFS27R1B, which is effective under *manual-mode* operation. While in uC-mode, the OAGC and hopping must be fixed or be controlled by external MCU.

4.2.2 Using *Smart-Detector*^{WB} in Manual-mode

- Set [MODE1:MODE0]=[00] to disable *Smart-Detector*^{WB}, then select a proper value for RSAW which makes the highest sensitivity. Note the default value is set OAGC[2:0] = {0,1,0} and HOPCLK=0.
- Set [MODE1:MODE0]=[11] to enable *Smart-Detector*^{WB}. Then the (OAGC2,OAGC1,OAGC0) is switched by following sequence. HOPCLK repeats “0” and “1” toggle every T seconds.

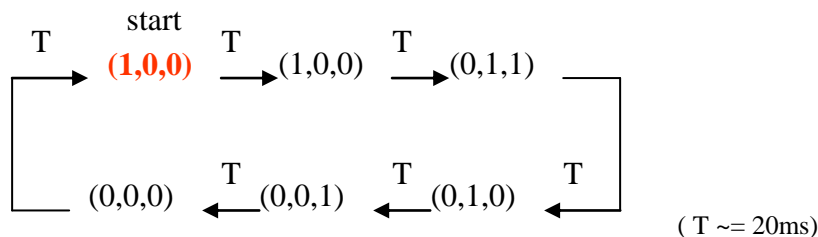

c). If a data packet is received, W55RFS27R1B stops OAGC and HOPCLK scan and holds the setting for a while(around 50ms), if no more data input, the OAGC and HOPCLK scan will be active again.

4.2.3 Using Smart-Detector^{WB} in uC-mode

- a). In *uC-mode*, [MODE1:MODE0]=[01], OAGC and HOPCLK are externally controlled. It can be fixed at a specific value or scanned as the sequence in manual-mode.
- b). When OAGC and HOPCLK are fixed, it should be set (OAGC2,OAGC1,OAGC0)=(0,1,0) and HOPCLK=0.
- c). If OAGC and HOPCLK are scanned as the proposed sequence; the switching time T should be adjusted depends on the data repeat time of the associate transmitter. Usually the switching time is twice the repeat transmission time of the transmitter. For example, if transmitter sends data every 10ms, then the switching time T should be 20ms.
- d). It is recommended to use fix setting (b) in *uC-mode* because it is difficult for MCU to control these pins. Components quality should be well controlled for the stability of mass-production.

4.3 W55RFS27R1B Layout Guide

- a). Antenna signal input path (ANT->C1->L0,C2,C3) must be short and without any noise source beside it.
- b). Oscillation tank components (L0,C2,C3) must be placed together and as closer to IC OSCin and OSCout pins as possible.
- c). Oscillator ground current return path (GNDA) must be shortest and widest to IC GNDA. It should be isolated with noise source, too.

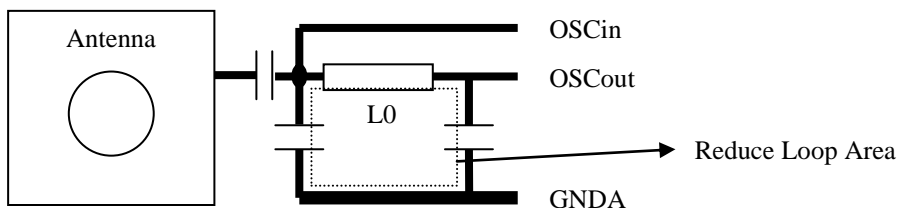

Pic.1 Graphic representation for a),b),c)

- d). Oscillation tank's ground is better to separate with other ground path and connect to chip's GNDA directly.

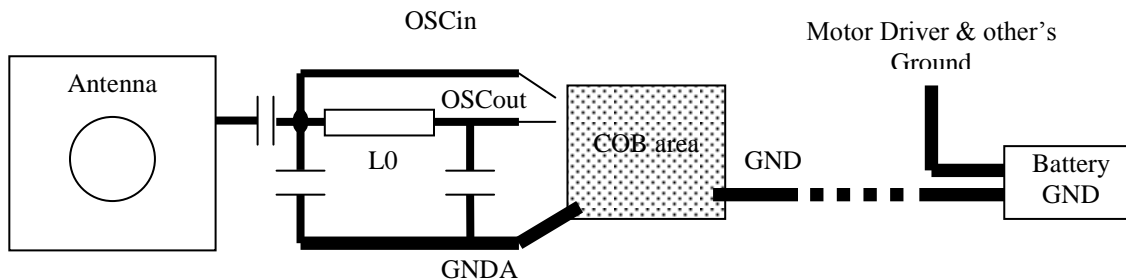

Pic.2 Graphic representation for d)

4.4 W55RFS27R1B Data Sheet Document History

Revision	Date	Description
A1.0	May 2004	Preliminary version
A2.0	Jul. 2004	Formal released version
A3.0	Feb. 2010	Logo changed

Important Notice

Nuvoton Products are neither intended nor warranted for usage in systems or equipment, any malfunction or failure of which may cause loss of human life, bodily injury or severe property damage. Such applications are deemed, "Insecure Usage".

Insecure usage includes, but is not limited to: equipment for surgical implementation, atomic energy control instruments, airplane or spaceship instruments, the control or operation of dynamic, brake or safety systems designed for vehicular use, traffic signal instruments, all types of safety devices, and other applications intended to support or sustain life.

All Insecure Usage shall be made at customer's risk, and in the event that third parties lay claims to Nuvoton as a result of customer's Insecure Usage, customer shall indemnify the damages and liabilities thus incurred by Nuvoton.

*Please note that all data and specifications are subject to change without notice.
All the trademarks of products and companies mentioned in this datasheet belong to their respective owners.*
