



PSA2045L THRU PSA2060L

PINGWEI ENTERPRISE

20.0AMPS. LOW VF MOS SCHOTTKY BARRIER RECTIFIERS

FEATURE

- . For surface mounted application
- . High current capability
- . Low forward voltage drop
- . Low power loss, high efficiency
- . High surge current capability
- . High temperature soldering guaranteed:
260°C/10 seconds at terminals.

MECHANICAL DATA

- . Terminal: Solder plated
- . Case: Molded with UL-94 Class V-0 recognized
Flame Retardant Epoxy

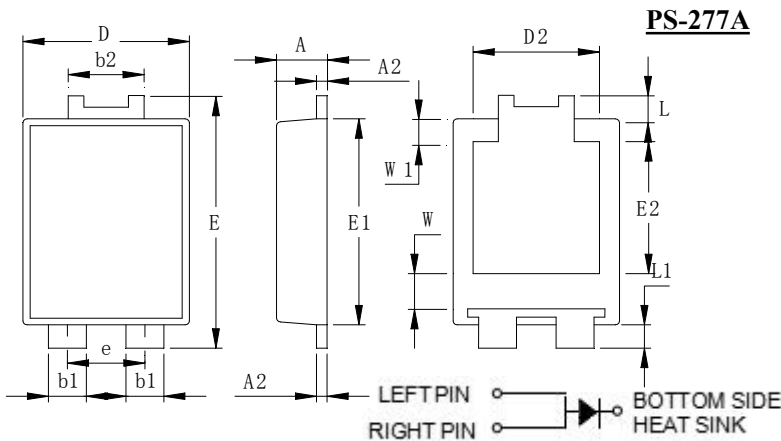

NO	Dimensions	NO	Dimensions
A	1.25±0.1	e	1.84Typ
A2	0.30±0.05	E1	6.25±0.1
b1	0.9±0.1	E2	3.6±0.2
b2	2.1±0.1	L	0.4±0.1
D	4.65±0.1	L1	0.4±0.1
D2	3.4Typ	W	1.2±0.2
E	7.05±0.1	W1	0.55±0.1

All Dimensions in mm

MAXIMUM RATINGS AND ELECTRICAL CHARACTERISTICS

Ratings at 25°C ambient temperature unless otherwise specified.

Single phase, half wave, 60Hz, resistive or inductive load. For capacitive load, derate current by 20%

Type Number	SYMBOL	PSA2045L	PSA2060L	units
Maximum Recurrent Peak Reverse Voltage	V_{RRM}	45	60	V
Maximum RMS Voltage	V_{RMS}	32	42	V
Maximum DC blocking Voltage	V_{DC}	45	60	V
Average Forward Rectified Output Current	$I_{F(AV)}$	20.0		A
Peak Forward Surge Current 8.3ms single half sine-wave superimposed on rated load (JEDEC method)	I_{FSM}	250.0		A
Maximum Instantaneous Forward Voltage at 2.0A DC	V_F	@T _A =25°C	0.33	0.35
Maximum Instantaneous Forward Voltage at 20.0A DC		@T _A =100°C	0.25	0.28
Maximum DC Reverse Current at rated DC blocking voltage	I_R	@T _A =25°C	0.45	0.55
		@T _A =100°C	0.40	0.48
Typical Junction Capacitance (Note1)	C_J	1200		pF
Typical Thermal Resistance (Note2)	$R_{(JA)}$	55		°C/W
	$R_{(JC)}$	12		
Storage Temperature	T_{STG}	-55 to +150		°C
Operating Junction Temperature	T_J	-55 to +150		°C

Note:

1. Measured at 1.0 MHz and applied reverse voltage of 4.0Vdc

2. Polyimide PCB, 2oz. Copper. Cathode pad dimensions 18.8mm x 14.4mm. Anode pad dimensions 5.6mm x 14.4mm.