



Solid State Devices, Inc.

14701 Firestone Blvd * La Mirada, Ca 90638
 Phone: (562) 404-4474 * Fax: (562) 404-1773
 ssdi@ssdi-power.com * www.ssdi-power.com

SSG55N60 series

**55 AMP /600 Volts
 1.65 V saturation
 ultrafast IGBT**

DESIGNER'S DATA SHEET

Part Number/Ordering Information ^{1/}
 SSG55N60

Screening ^{2/}

- = Not Screened
- TX = TX Level
- TXV = TXV
- S = S Level

Package Type

- M = TO-254
- Z = TO-254Z
- N = TO-258
- P = TO-259
- /3 = TO-3

Features:

- Lowest ON-resistance in the industry
- Hermetically Sealed, Isolated Package
- Low Total Gate Charge
- Fast Switching
- TX, TXV, S-Level screening available

Maximum Ratings	Symbol	Value	Units
Collector – Emitter Breakdown Voltage	V_{CES}	600	V
Gate – Emitter Voltage	V_{GE}	±20	V
Max. Continuous Collector Current	I_{D1} I_{D2}	55 27	A
Max. Instantaneous Drain Current (Tj limited)	I_{D3}	200	A
Clamped Inductive Load current	I_{LM}	200	A
Repetitive Reverse Voltage Avalanche Energy	E_{ARV}	20	mJ
Total Power Dissipation	P_D	195	W
Operating & Storage Temperature	T_{OP} & T_{STG}	-55 to +150	°C
Maximum Thermal Resistance (Junction to Case)	$R_{\theta JC}$	0.64 (typ 0.35)	°C/W

TO-254 (M)

TO-254Z (Z)

TO-258 (N)

TO-259 (P)

TO-3 (/3)

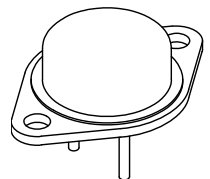
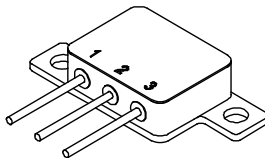
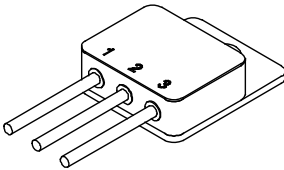
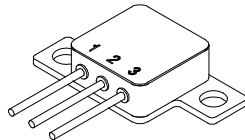
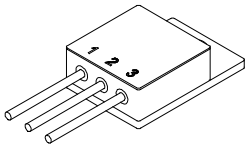

NOTES: *Pulse Test: Pulse Width = 300µsec, Duty Cycle = 2%.
 1/ For ordering information, price, and availability - contact factory.
 2/ Screening based on MIL-PRF-19500. Screening flows available on request.
 3/ Unless otherwise specified, all electrical characteristics @25°C.



Solid State Devices, Inc.

14701 Firestone Blvd * La Mirada, Ca 90638

Phone: (562) 404-4474 * Fax: (562) 404-1773

ssdi@ssdi-power.com * www.ssdi-power.com

SSG55N60 series

Electrical Characteristics ^{3/}		Symbol	Min	Typ	Max	Units
Collector to Emitter Breakdown Voltage	$V_{GE} = 0V, I_C = 250\mu A$	BV_{CES}	600	—	—	V
Emitter to Collector Breakdown Voltage	$V_{GE} = 0V, I_C = 1 A$	BV_{ECS}	18	—	—	V
Collector to Emitter Saturation Voltage	$V_{GE} = 15V, I_C = 27A, T_j = 25^\circ C$	$V_{CE(on)}$	—	1.65	2.0	V
	$V_{GE} = 15V, I_C = 55A, T_j = 25^\circ C$		—	2.0	—	
	$V_{GE} = 15V, I_C = 27A, T_j = 150^\circ C$		—	1.6	—	
Gate Threshold Voltage	$V_{CE} = V_{GE}, I_C = 0.25 mA$	$V_{GS(th)}$	3.0	—	6.0	V
Gate to Emitter Leakage	$V_{GE} = \pm 20V$	I_{GES}	—	—	± 100	nA
Zero Gate Voltage Collector Current	$V_{CE} = 600V, V_{GE} = 0V, T_j = 25^\circ C$	I_{CES}	—	0.5	250	μA
	$V_{CE} = 10V, V_{GE} = 0V, T_j = 25^\circ C$		—	—	2	μA
	$V_{CE} = 600V, V_{GE} = 0V, T_j = 150^\circ C$		—	—	5000	μA
Forward Transconductance	$V_{CE} = 15V, I_C = 27A, T_j = 25^\circ C$	g_{fs}	15	25	—	Mho
Total Turn-on Gate Charge	$V_{GE} = 15V$	Q_g	—	150	275	nC
Gate to Emitter Turn-on Charge	$V_{CC} = 400V$	Q_{ge}	—	25	40	
Gate to Collector Turn-on Charge	$I_C = 27A$	Q_{gc}	—	60	90	
Turn on Delay Time	$V_{GE} = 15V, V_{CC} = 480V, I_C = 27A, R_G = 5.0\Omega, T_j = 25^\circ C$	$t_{d(on)}$	—	50	70	nsec
Rise Time		t_r	—	125	—	
Turn off Delay Time		$t_{d(off)}$	—	250	300	
Fall Time		t_f	—	120	150	
Turn-On Switching Losses	$V_{GE} = 15V, V_{CC} = 480V, I_C = 27A, R_G = 5.0\Omega, T_j = 25^\circ C$	E_{on}	—	0.12	—	mJ
Turn-Off Switching Losses		E_{off}	—	0.55	—	
Total Switching Losses		E_{ts}	—	0.66	0.9	
Turn on Delay Time	$V_{GE} = 15V, V_{CC} = 480V, I_C = 27A, R_G = 5.0\Omega, T_j = 150^\circ C$	$t_{d(on)}$	—	90	120	ns
Rise Time		t_r	—	600	—	ns
Turn off Delay Time		$t_{d(off)}$	—	230	300	ns
Fall Time		t_f	—	1200	—	ns
Total Switching Losses		E_{ts}	—	1.6	—	mJ
Input Capacitance	$V_{GE} = 0V$	C_{ies}	—	4000	—	pF
Output Capacitance	$V_{CC} = 30V$	C_{oes}	—	250	—	
Reverse Transfer Capacitance	$f = 1 MHz$	C_{res}	—	20	—	

TO-254 (M)

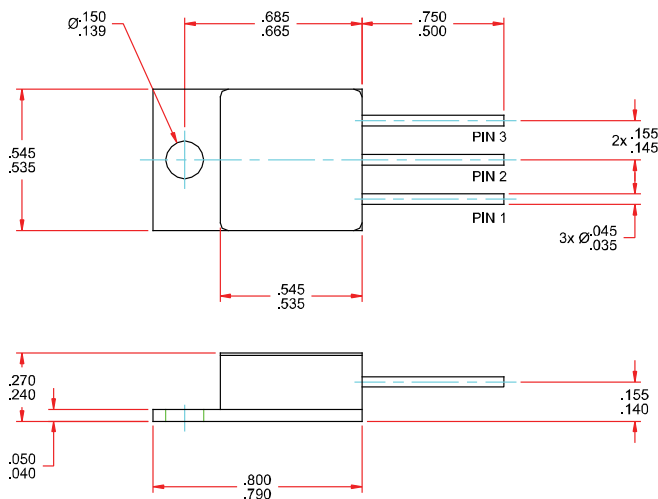

TO-254Z (Z)

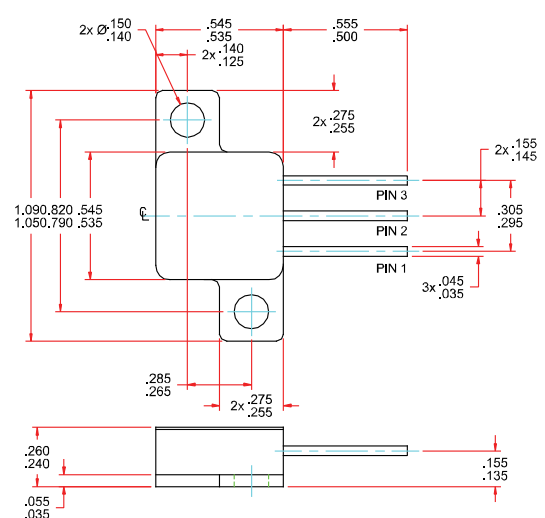

NOTE: All specifications are subject to change without notification. SCD's for these devices should be reviewed by SSDI prior to release.

DATA SHEET #: TG0005C

DOC



Solid State Devices, Inc.

14701 Firestone Blvd * La Mirada, Ca 90638
 Phone: (562) 404-4474 * Fax: (562) 404-1773
 ssdi@ssdi-power.com * www.ssdi-power.com

SSG55N60 series

TO-258 (N)

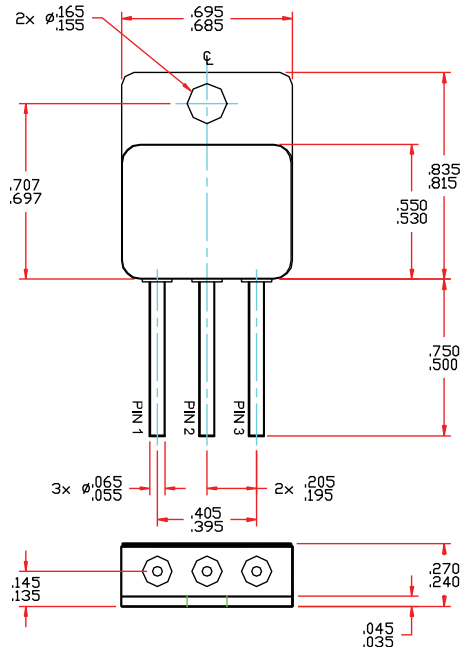

TO-259 (P)

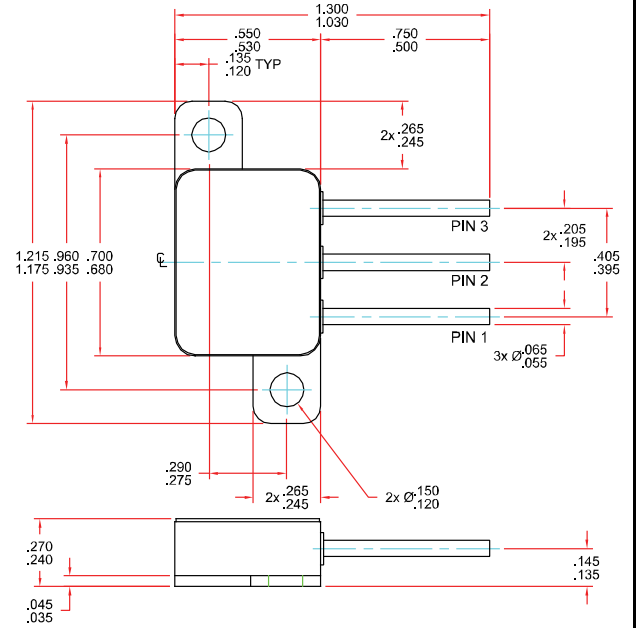

TO-3 (/3)

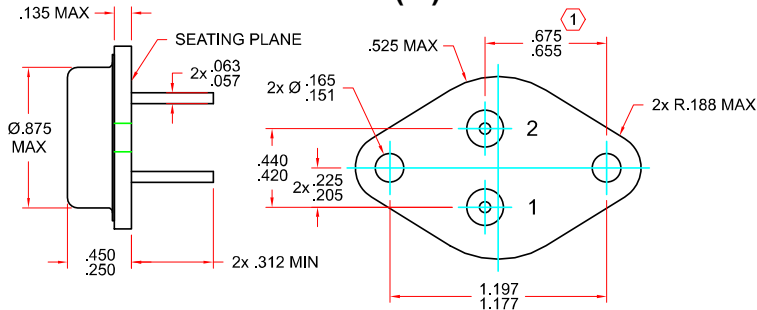

NOTES:

- ① THIS DIMENSION SHALL BE MEASURED AT POINTS $.050 - .055$ " BELOW THE SEATING PLANE. WHEN GAGE IS NOT USED, MEASUREMENT WILL BE MADE AT SEATING PLANE.
- THIS OUTLINE DOES NOT MEET THE MINIMUM CRITERIA ESTABLISHED BY JS-10 FOR REGISTRATION.

PIN ASSIGNMENT (Standard)

Package	Collector	Emitter	Gate
TO-254 (M)	Pin 1	Pin 2	Pin 3
TO-254Z (Z)	Pin 1	Pin 2	Pin 3
TO-258 (N)	Pin 1	Pin 2	Pin 3
TO-259 (P)	Pin 1	Pin 2	Pin 3
TO-3 (/3)	Case	Pin 2	Pin 1

Available Part Numbers:

- SSG55N60M
- SSG55N60Z
- SSG55N60N
- SSG55N60P
- SSG55N60/3

NOTE: All specifications are subject to change without notification. SCD's for these devices should be reviewed by SSDI prior to release.

DATA SHEET #: TG0005C

DOC