



LR1148

CMOS IC

600mA LOW DROPOUT LINEAR REGULATOR

■ **DESCRIPTION**

The UTC **LR1148** belonged to low-noise, low-dropout, linear regulators operate from 2.3V to 6V input and are guaranteed to deliver 600mA. Wide range of preset output voltage options are available. Built-in low on-resistance transistor provides low dropout voltage and large output current. The UTC **LR1148** is designed and optimized for battery-powered systems to work with low noise.

The UTC **LR1148** consumes less than 0.01μA in shutdown mode. Other features include ultra low dropout voltage, current limiting protection, thermal shutdown protection and high ripple rejection ratio.

■ **FEATURES**

- * 600mA Guaranteed Output Current
- * 0.01μA Shutdown Current
- * Ultra Low Dropout Voltage
- * Low Temperature Coefficient
- * Current Limiting Protection
- * Thermal Shutdown Protection
- * Excellent Line/Load Transient

■ **ORDERING INFORMATION**

Ordering Number		Package	Pin Assignment					Packing
Lead Free	Halogen Free		1	2	3	4	5	
LR1148L-xx-AF5-R	LR1148G-xx-AF5-R	SOT-25	I	G	S	A	O	Tape Reel

Note: Pin Assignment: I:V_{IN} O:V_{OUT} G:GND S:EN A:ADJ

<p>LR1148L-xx-AF5-R</p> <ul style="list-style-type: none"> (1) Packing Type (2) Package Type (3) Output Voltage Code (4) Lead Free 	<ul style="list-style-type: none"> (1) R: Tape Reel (2) AF5: SOT-25 (3) xx: refer to Marking Information (4) L: Lead Free, G: Halogen Free
--	--

■ **MARKING INFORMATION**

PACKAGE	VOLTAGE CODE	MARKING
SOT-25	AD :ADJ	<p>Voltage Code ← SRXX → L: Lead Free G: Halogen Free</p>

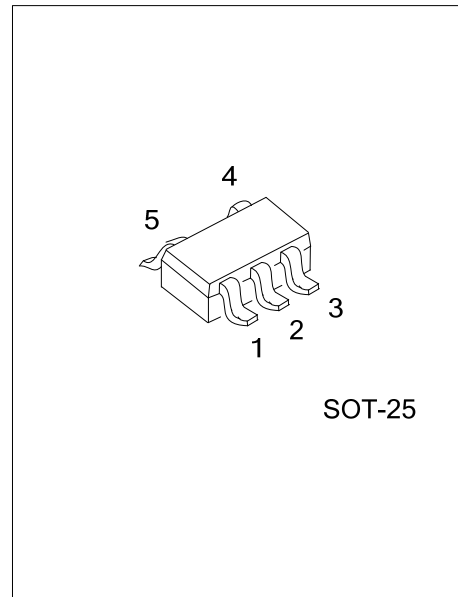

■ PIN CONFIGURATION

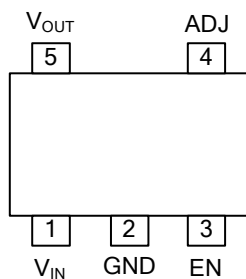

■ PIN DESCRIPTION

PIN NAME	DESCRIPTION
V _{IN}	Power Input Voltage. Supply voltage can range from 2.3V to 6V. Bypass with a 1μF capacitor to GND.
GND	Ground
EN	Active-Low Shutdown Input. A logic low at EN reduces supply current to 0.01μA. Connect EN to V _{IN} for normal operation.
V _{OUT}	Output Voltage
ADJ	Voltage-adjust Input. Connect ADJ to GND for preset output. Connect an external resistive voltage-divider from V _{OUT} to ADJ to set the output voltage between 0.8V and 5V.

■ BLOCK DIAGRAM

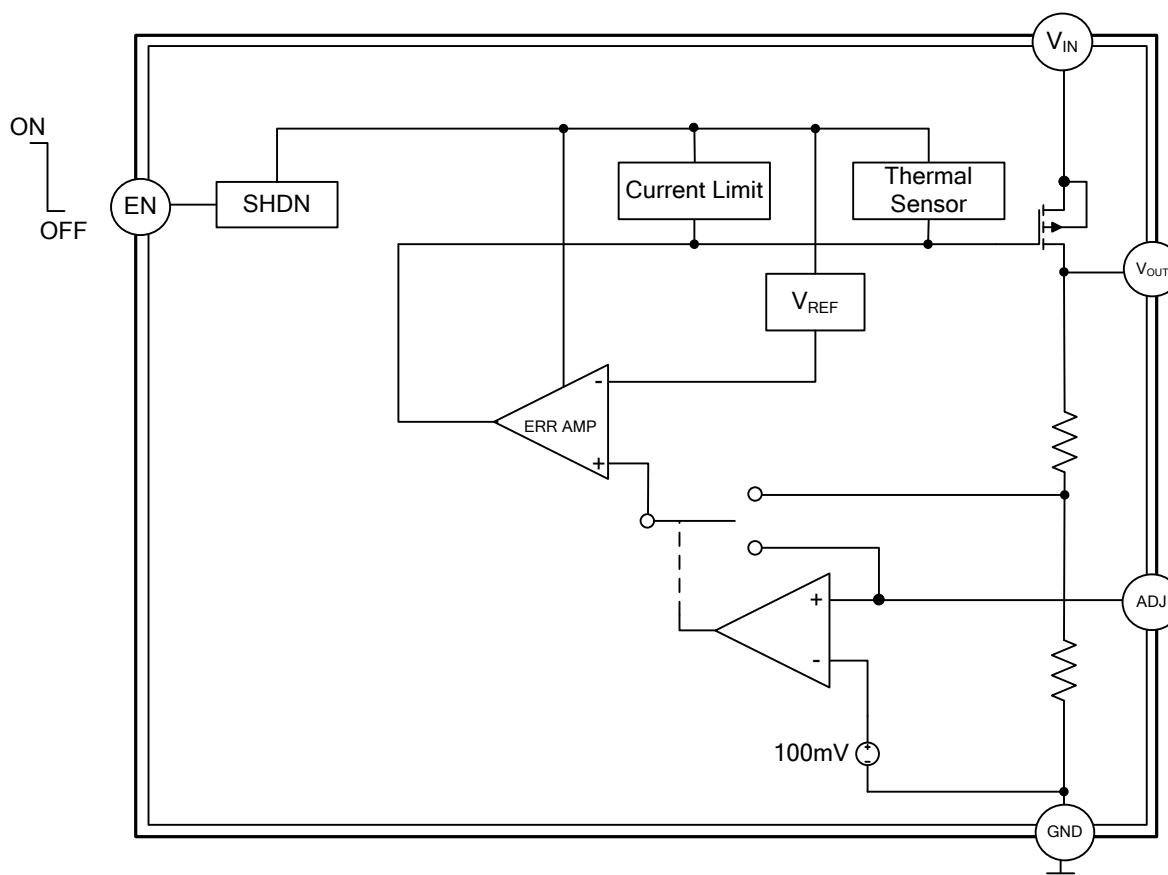

■ ABSOLUTE MAXIMUM RATING (T_A=25°C)

PARAMETER	SYMBOL	RATINGS	UNIT
Supply Voltage	V _{IN}	6.5	V
Power Dissipation	P _D	360	mW
Junction Temperature	T _J	+125	°C
Ambient Operating Temperature	T _{OPR}	-40 ~ +85	°C
Storage Temperature	T _{STG}	-65 ~ +150	°C

Note: Absolute maximum ratings are those values beyond which the device could be permanently damaged. Absolute maximum ratings are stress ratings only and functional device operation is not implied.

■ THERMAL DATA

PARAMETER	SYMBOL	RATINGS	UNIT
Junction to Ambient	θ _{JA}	260	°C/W
Junction to Case	θ _{JC}	81	°C/W

■ ELECTRICAL CHARACTERISTICS

(C_{IN} = 1μF, C_{OUT} = 1μF, T_A = 25°C, unless otherwise specified)(Note 1)

PARAMETER	SYMBOL	TEST CONDITIONS	MIN	TYP	MAX	UNIT
Input Voltage(Note 2)	V _{IN}		2.3		6	V
Output Voltage Accuracy (Preset Mode)	V _{OUT}	T _A = 25°C, I _{OUT} = 1mA ~ 0.6A	-2		2	%
		T _A = 0~85°C, I _{OUT} = 1mA~0.6A	-3		3	%
Maximum Output Current	I _{OUT}			600		mA
Short-Circuit Current Limit	I _{LIMIT}	V _{OUT} = 0V		1		A
Ground Pin Current	I _{GND}	I _{OUT} = 0mA		70		μA
		I _{OUT} = 1mA to 600mA		80		μA
Dropout Voltage (Note3)	V _D	I _{OUT} = 600mA	V _{OUT(NOM)} ≤ 1.8V	500	1200	mV
			1.8V < V _{OUT(NOM)}	200	450	
Line Regulation (Note4)	$\frac{\Delta V_{OUT}}{\Delta V_{IN} \times V_{OUT}}$	V _{IN} = V _{OUT} + V _D ~ 6V		0.08	0.55	%/V
Load Regulation(Note4,5)	ΔV _{OUT}	V _{IN} = V _{OUT} + V _D , I _{OUT} = 10mA ~ 600mA		0.25	1.0	%
Output Voltage Noise	eN	f = 10Hz to 100kHz, C _{BP} = 0.1nF		24		μV _{RMS}
Shutdown Supply Current	I _{OFF}	EN = GND		0.01	5	μA
Shutdown Threshold	V _{IH}		2			V
	V _{IL}				0.4	V
Thermal Shutdown Temperature	T _{SHDN}			170		°C
Thermal Shutdown Hysteresis	DT _{SHDN}			20		°C
ADJ Voltage	V _{REF}	Measured on ADJ, I _{OUT} = 10mA	0.774	0.8	0.826	V
ADJ Mode Threshold				100		mV
Adjustable Output Voltage			0.8		5	V

Note: 1. Specifications are production tested at T_A = 25°C. Specifications over the -40°C to 85°C operating temperature range are assured by design, characterization and correlation with Statistical Quality Controls(SQC).

- The minimum operating value for V_{IN} is equal to either [V_{OUT(NOM)} + V_D] or 2.3V, whichever is greater
- Dropout voltage is defined as the voltage from the input to output when output is 2% below the nominal value.
- Output voltage line regulation is defined as the change in output voltage from the nominal value resulting from a change in the input line voltage. Output voltage load regulation is defined as the change in output voltage from the nominal value as the load current increases from no load to full load.
- Regulation is measured at constant junction temperature by using a 20ms current pulse. Devices are tested for load regulation in the load range from 10mA to 600mA

■ TYPICAL APPLICATION CIRCUIT

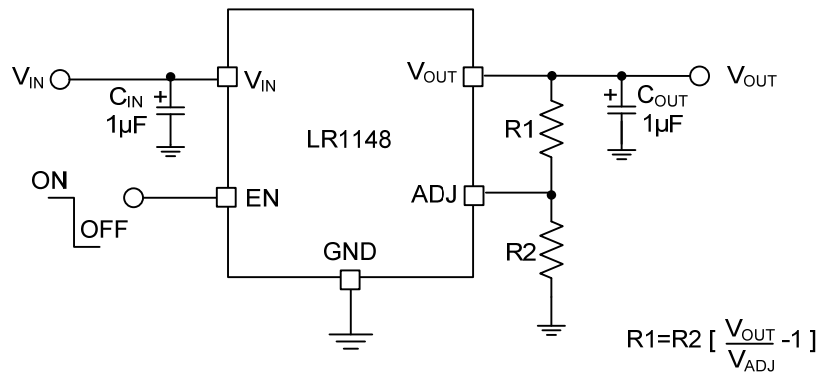

UTC assumes no responsibility for equipment failures that result from using products at values that exceed, even momentarily, rated values (such as maximum ratings, operating condition ranges, or other parameters) listed in products specifications of any and all UTC products described or contained herein. UTC products are not designed for use in life support appliances, devices or systems where malfunction of these products can be reasonably expected to result in personal injury. Reproduction in whole or in part is prohibited without the prior written consent of the copyright owner. The information presented in this document does not form part of any quotation or contract, is believed to be accurate and reliable and may be changed without notice.