

PART NUMBER	REV	FIRST USED	POWER UNIT	FEED TYPE
1385838-1	B	122500-1	LEADMAKER	POST FEED
1385838-2	B	565435-5	BENCH MODEL K	PRE FEED
1385838-3	B	354500-1	BENCH MODEL G	PRE FEED

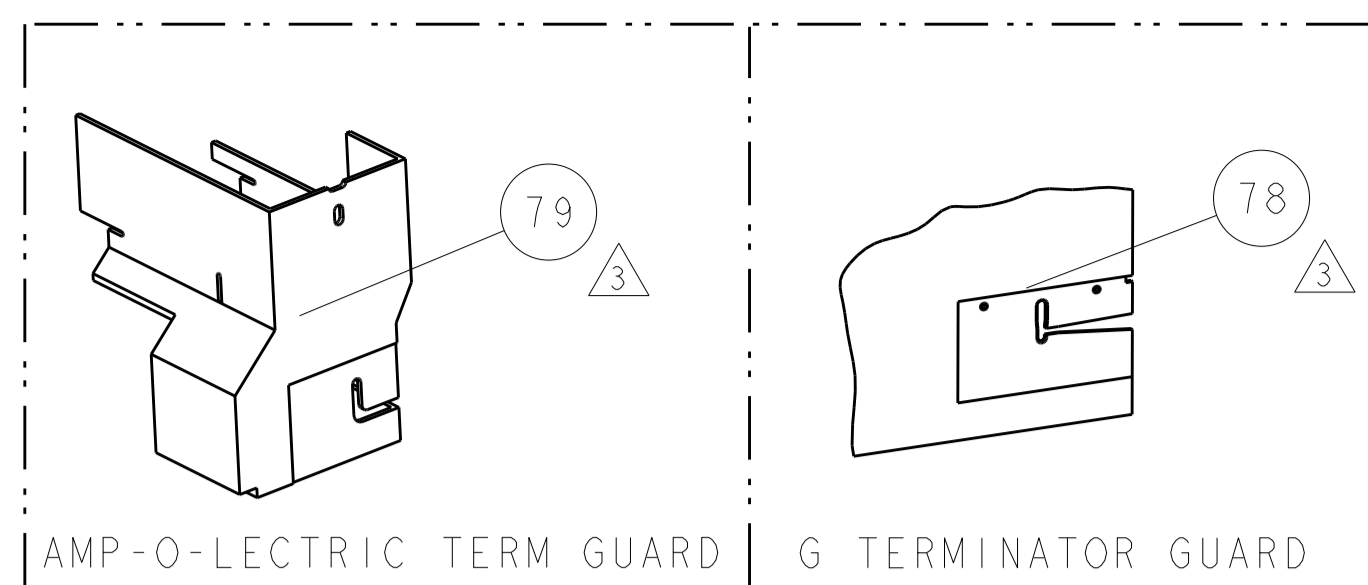

TERMINAL NAME: NSF-0.3

TE PN	MFR PN	MITSUBISHI TERMINAL AND CRIMP SPECS			
1642755-1	MT095-94280				
		PAD LTR	CRIMP HEIGHT	WIRE SIZE	
		A	.053±.002[1.35±0.05mm]	1.25 mm2	
		B	.045±.002[1.14±0.05mm]	0.85 mm2	
		C			
		D			
		CRIMP	SIZE	TYPE RANGE	
		WIRE	.092 [2.34mm]	F 1.25-.085mm2	
		INSUL	.112 [2.84mm]	F 2.3mm MAX	
WIRE STRIP LENGTH	TERM APPL SPEC	FEED	APPL INSTRUCTIONS	SET UP GAGE	
.177-.216	NONE	.591	408-8040	458637-1	

LOC	DIST	REVISIONS			
A	66	REV	DATE	BY	CHKD
		A	22OCT2004	LG	TE
		A1	15JUN2006	MY	GB
		B	16AUG2010	MY	TE
		B1	27MAR2015	JH	JT

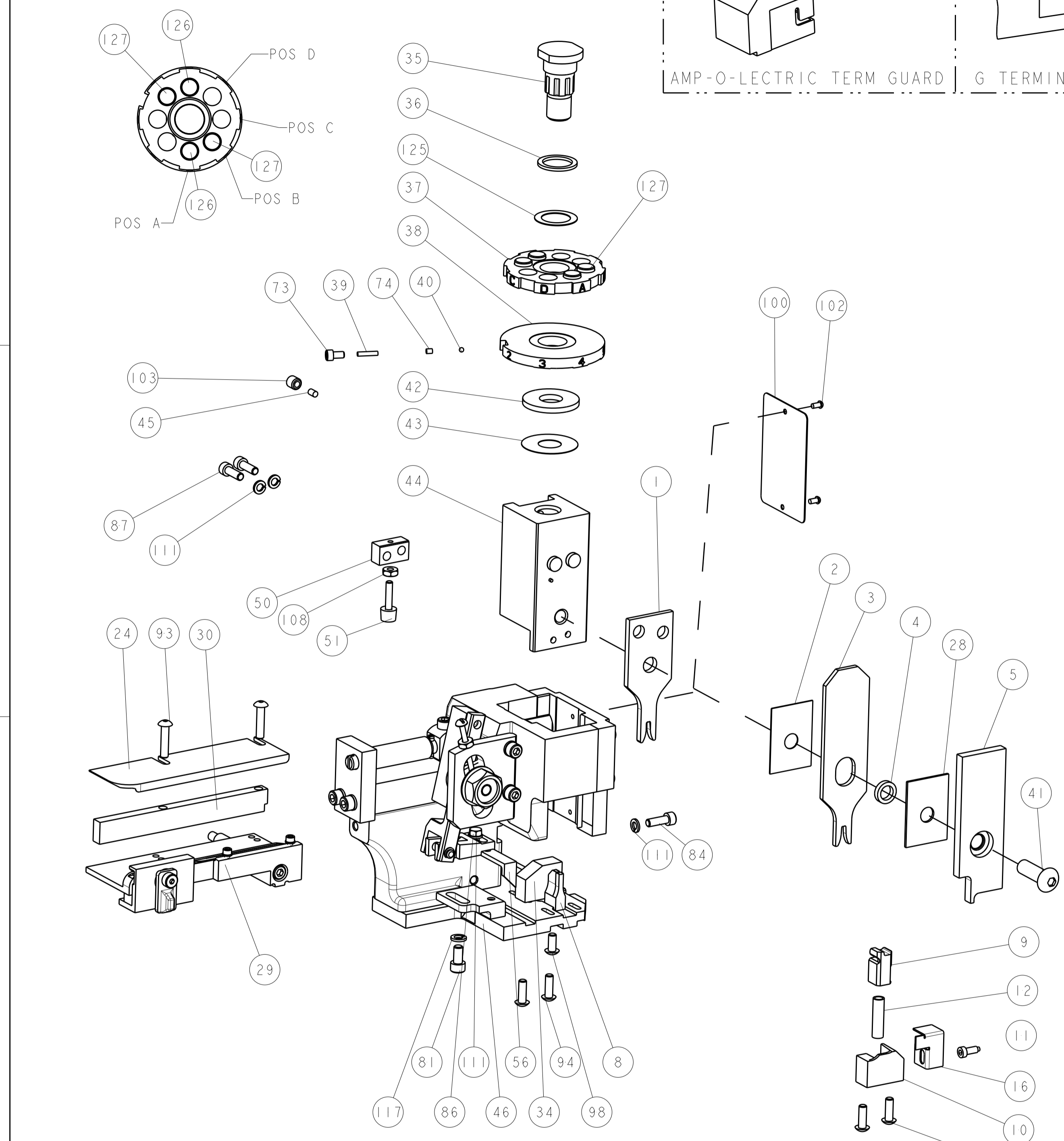

- △ RECOMMENDED SPARE PARTS
- △ GREASE LIGHTLY
- △ GUARD MUST BE IN PLACE WHEN OPERATING APPLICATOR IN A BENCH MACHINE

-	-	-	-	-	-	129
-	-	-	-	-	-	128
-	-	-	-	-	-	127
2	2	2	-	4-354779-0	PIN, WIRE DISC, .3190	126
2	2	2	-	2-354779-4	PIN, WIRE DISC, .3110	125
1	1	1	-	986950-1	WASHER, FLAT PRECISION	124
1	1	1	-	217238-1	GENERAL INSTRUCTION PKG	123
1	1	1	-	4088040	SF APPL INST 408-8040	122
-	-	-	-	-	-	121
-	-	-	-	-	-	120
-	-	-	-	-	-	119
-	-	-	-	-	-	118
1	1	1	-	21024-5	WASHER, SPRG LOCK, REG NO 10	117
-	-	-	-	-	-	116
-	-	-	-	-	-	115
-	-	-	-	-	-	114
-	-	-	-	-	-	113
-	-	-	-	-	-	112
4	4	4	-	21024-4	WASHER, SPRG LOCK, REG NO 8	111
-	-	-	-	-	-	110
-	-	-	-	-	-	109
1	1	1	-	21018-5	NUT, HEX, REG 6-32	108
-	-	-	-	-	-	107
-	-	-	-	-	-	106
-	-	-	-	-	-	105
-	-	-	-	-	-	104
1	1	1	-	21009-2	SCR, SET, SELF LOCKING 1/4-20 X .250	103
2	2	2	-	21017-2	SCREW, DRIVE	102
-	-	-	-	-	-	101
1	1	1	-	461264-1	PLATE, IDENTIFICATION	100
-	-	-	-	-	-	99
1	1	1	-	22733-8	SCR, BHSC, SELF-LOCKING, 8-32 X .375	98
-	-	-	-	-	-	97
-	-	-	-	-	-	96
-	-	-	-	-	-	95
4	4	4	-	2-21002-2	SCR, BTN SKT HD CAP 8-32 X .500	94
2	2	2	-	2-21002-4	SCR, BTN SKT HD CAP 8-32 X .750	93
-	-	-	-	-	-	92
1	1	1	-	1-21002-7	SCR, BTN SKT HD CAP 6-32 X .375	91
-	-	-	-	-	-	90
-	-	-	-	-	-	89
-	-	-	-	-	-	88
-	-	-	-	-	-	87
2	2	2	-	2-21000-7	SCR, SKT HD CAP 8-32 X .500	86
1	1	1	-	2-22603-0	SCR, HEX HD CAP 8-32 X .312	85
-	-	-	-	-	-	84
1	1	1	-	2-21000-7	SCR, SKT HD CAP 8-32 X .500	83
-	-	-	-	-	-	82
-	-	-	-	-	-	81
1	1	1	-	3-21000-4	SCR, SKT HD CAP 10-32 X .375	80
-	-	-	-	-	-	79
-	-	-	-	-	-	78
-	-	-	-	-	-	77
-	-	-	-	-	-	76
-	-	-	-	-	-	75
-	-	-	-	-	-	74
1	1	1	-	690603-1	SPRING ASSIST AMP-O-MATOR APPLICATOR	73
-3	-2	-1	U/M	PART NO	DESCRIPTION	ITEM NO

-	-	-	-	23030-1	SCR, SKT HD CAP 6-32 x .25	73
-	-	-	-	-	-	72
-	-	-	-	-	-	71
-	-	-	-	-	-	70
-	-	-	-	-	-	69
-	-	-	-	-	-	68
-	-	-	-	-	-	67
-	-	-	-	-	-	66
-	-	-	-	-	-	65
-	-	-	-	-	-	64
-	-	-	-	-	-	63
-	-	-	-	-	-	62
-	-	-	-	-	-	61
-	-	-	-	-	-	60
-	-	-	-	-	-	59
-	-	-	-	-	-	58
-	-	-	-	-	-	57
1	1	1	-	458537-2	PAWL, FEED	56
-	-	-	-	-	-	55
-	-	-	-	-	-	54
-	-	-	-	-	-	53
-	-	-	-	-	-	52
1	1	1	-	811242-2	BUMPER, HOLD DOWN	51
1	1	1	-	690753-1	SPACER, TONKER	50
1	-	-	-	690602-6	CAM, PRE FEED, 1 5/8	49
-	1	-	-	690602-5	CAM, POST FEED, 1 1/8	48
-	-	1	-	690501-4	CAM, POST-FEED 1 5/8	47
1	1	1	-	459456-1	APPL. BASIC SUB ASSEMBLY	46
1	1	1	-	690191-1	PLUG, NYLON	45
1	1	1	-	455673-1	RAM	44
1	1	1	-	690125-1	SHIM SUB-ASSY	43
1	1	1	-	690124-1	WASHER, RAM (.115)	42
1	1	1	-	7-21002-9	SCR, BTN SKT HD CAP 5/16-24 X 1.00	41
1	1	1	-	23241-6	BALL, STEEL	40
1	1	1	-	690170-1	SPRING, COMPRESSION	39
1	1	1	-	1-690142-1	DISC, INSULATION	38
1	1	1	-	354777-1	WIRE DISC, ASSEMBLY	37
1	1	1	-	22480-5	SPRING, COMPRESSION	36
1	1	1	-	690212-1	POST, RAM	35
1	1	1	-	690786-1	TERMINAL SUPPORT	34
-	-	-	-	-	-	33
-	-	-	-	-	-	32
-	-	-	-	-	-	31
1	1	1	-	1320908-1	SPACER, STRIP GUIDE	30
1	1	1	-	1633091-1	ASSEMBLY, STRIP GUIDE	29
1	1	1	-	1-455888-0	SPACER, CRIMPER	28
-	-	-	-	-	-	27
-	-	-	-	-	-	26
-	-	-	-	-	-	25
1	1	1	-	1320928-1	STRIP GUIDE	24
-	-	-	-	-	-	23
-	-	-	-	-	-	22
-	-	-	-	-	-	21
-	-	-	-	-	-	20
1	1	1	-	691353-1	STRIPPER	19
-	-	-	-	-	-	18
-	-	-	-	-	-	17
1	1	1	-	318563-1	GUARD, FRONT CHIP	16
-	-	-	-	-	-	15
-	-	-	-	-	-	14
-	-	-	-	-	-	13
1	1	1	-	3-22280-3	SPRING, COMPRESSION	12
1	1	1	-	690461-1	STOP, SHEAR	11
1	1	1	-	690459-1	SHEAR HOLDER, FRONT	10
1	1	1	-	454276-1	FLOATING SHEAR, FRONT	9
1	1	1	-	1-1633116-3	ANVIL, COMBINATION	8
-	-	-	-	-	-	7
-	-	-	-	-	-	6
1	1	1	-	1-455889-4	DEPRESSOR, SHEAR	5
1	1	1	-	238011-9	BLOCK, CRIMPER SPACER	4
1	1	1	-	1-1424909-1	CRIMPER, INSULATION F	3
1	1	1	-	455888-4	SPACER, CRIMPER	2
1	1	1	-	1-1673600-4	CRIMPER, WIRE	1

