

Pb Free Plating Product

MUR8020PT



80Amperes,200Volts Heatsink Common Cathode Ultra Fast Recovery Rectifiers

APPLICATION

- Freewheeling, Snubber, Clamp
- Inversion Welder
- PFC
- Plating Power Supply
- Ultrasonic Cleaner and Welder
- Converter & Chopper
- UPS

PRODUCT FEATURE

- Ultrafast Recovery Time
- Soft Recovery Characteristics
- Low Recovery Loss
- Low Forward Voltage
- High Surge Current Capability
- Low Leakage Current

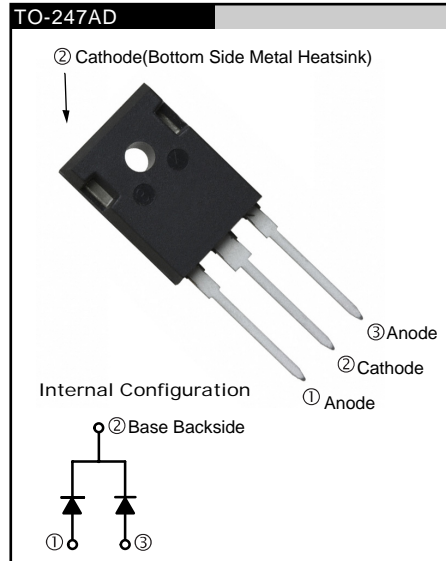

GENERAL DESCRIPTION

MUR8020PT using the latest FRED FAB process(planar passivation chip) with ultrafast and soft recovery characteristic.

Absolute Maximum Ratings

Parameter	Symbol	Test Conditions	Values	Units
Repetitive peak reverse voltage	V_{RRM}		200	V
Continuous forward current	$I_{F(AV)}$	$T_c = 110^\circ\text{C}$	80	A
Single pulse forward current	I_{FSM}	$T_c = 25^\circ\text{C}$	800	
Maximum repetitive forward current	I_{FRM}	Square wave, 20kHz	320	
Operating junction	T_j		175	$^\circ\text{C}$
Storage temperatures	T_{stg}		-55 to +175	$^\circ\text{C}$

Electrical characteristics ($T_a=25^\circ\text{C}$ unless otherwise specified)

Parameter	Symbol	Test Conditions	Min	Typ.	Max.	Units
Breakdown voltage Blocking voltage	V_{BR}, V_R	$I_R=100\mu\text{A}$	200			V
Forward voltage (Per Diode)	V_F	$I_F=40\text{ A}$		0.97	1.20	
		$I_F=40\text{ A}, T_j=125^\circ\text{C}$		0.86	1.00	
Reverse leakage current(Per Diode)	I_R	$V_R=V_{RRM}$			10	μA
		$T_j=150^\circ\text{C}, V_R=200\text{V}$			100	
Reverse recovery time(Per Diode)	t_{rr}	$I_F=0.5\text{A}, I_R=1\text{A}, I_{RR}=0.25\text{A}$		37	50	ns
		$I_F=1\text{A}, V_R=30\text{V}, di/dt=-200\text{A}/\mu\text{s}$		25	40	

Thermal characteristics

Paramter	Symbol	Typ	Units
Junction-to-Case	$R_{\theta JC}$	0.8	$^\circ\text{C}/\text{W}$

Electrical performance (typical)

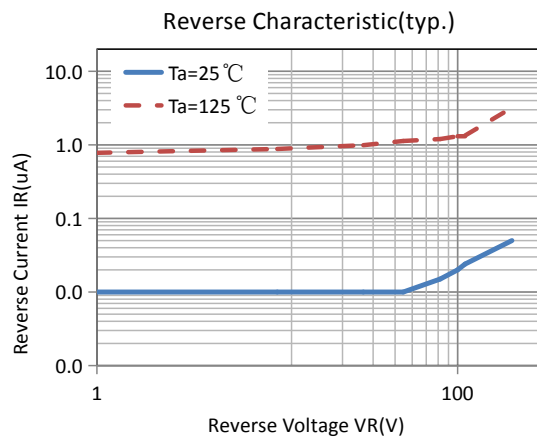
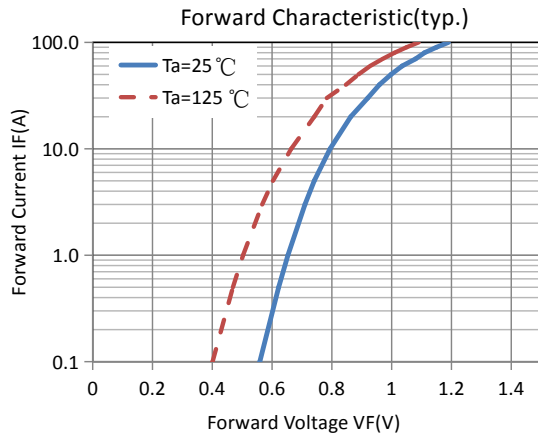

Package Information

TO-247 PACKAGE

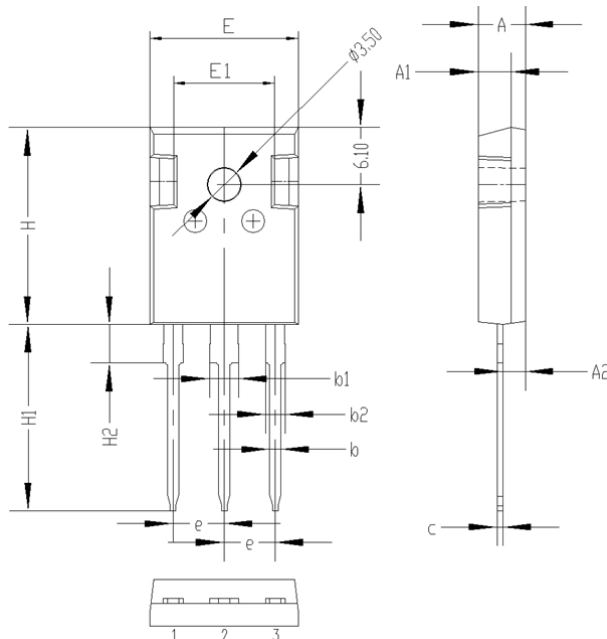

Symbol	Dimensions (millimeters)	
	Min.	Max.
A	4.80	5.20
A1	3.30	3.70
A2	2.10	2.50
b	1.00	1.40
b1	2.90	3.30
b2	1.90	2.30
c	0.40	0.80
e	5.25	5.65
E	15.6	16.0
E1	10.6	11.00
H	20.8	21.2
H1	19.4	20.4
H2	3.90	4.30
G	5.90	6.30
ΦP	3.30	3.70