



DS2740EVKIT High-Precision Coulomb Counter IC Evaluation Kit

www.maxim-ic.com

FEATURES

- Demonstrates the Capabilities of the DS2740 High-Precision Coulomb Counting IC Including:
 - Real-Time Current Measurements
 - High-Precision Current Accumulation
 - Identification
 - Programmable I/O Operation
- Interfaces to the USB Port of a PC Running Windows® XP or Older Operating System



PD122402*
DS2740EVKIT+ TSSOP

INDEX

Evaluation Kit Contents
Equipment Needed
Introduction
Setup and Installation
 Board Connections
 Software Installation
 Selecting the COM Port
Program Menus
Program Tabs
 Meters Tab
 Data Log Tab
 Memory Tab
 Pack Information Tab

Windows XP is a registered trademark of Microsoft Corp.

INTRODUCTION

The DS2740 evaluation kit (EV kit) makes performance evaluation, software development, and prototyping with the DS2740 high-precision coulomb counting IC easy. The evaluation board interfaces to a PC running Windows XP or older through a DS9123O USB adapter and RJ-11 cable connection.

The DS2740 EV kit evaluation software gives the user complete control of all functions of the DS2740. Separate control tabs allow the user access to all memory locations, all status registers, and real-time updates of all monitored parameters. The software also incorporates a data-logging feature to monitor a battery over time.

The evaluation board circuit is designed to provide the DS2740 with accurate parameter measurements and protect the DS2740 from ESD damage.

**Kit demonstration boards will vary as they are improved upon over time. For information on the demonstration board circuits visit our website at www.maxim-ic.com.*

EVALUATION KIT CONTENTS

- 1 pc. TSSOP Evaluation Board
- 1 pc. DS9123 Serial Port Adapter
- 1 pc. RJ-11 Phone Cable

EQUIPMENT NEEDED

- 1) A PC running Windows XP or older operating system with an available USB port.
- 2) Cables with mini-grabber style clips or the ability to solder directly to connection pads.
- 3) A Lithium-Ion (Li+) battery or 3-cell NiMH stack and a power supply and/or load circuit.

ORDERING INFORMATION

PART	TYPE
DS2740EVKIT+	EV Kit

+Denotes lead(Pb)-free and RoHS compliant.

SETUP AND INSTALLATION

Board Connections

Connections to the demonstration board are best made either by soldering directly to the pads or by using cables with mini-grabber clips. Communication to the board can be accomplished by connecting the RJ-11 jack to the DS91230 USB adapter with the 2 conductor cable provided. Then the DQ and PAC- terminals on the RJ-11 jack can be wired directly to the DQ and PAC- pads on the demonstration board.

Figure 1 shows the recommended circuit for the DS2740 EV kit board. The Li+ cell or NiMH cell stack is connected between the BAT+ and BAT- pads. If a Li+ cell is used a protection circuit must be included between the battery and the demo board. The user system load circuit/charger is connected from BAT+ to PAC-. The evaluation software can be run with or without a load or charger as long as a cell is connected between the BAT+ and BAT- terminals providing a minimum of 2.7V to power the DS2740.

Figure 1. PD122402 Cell, Load, and Charger Connections

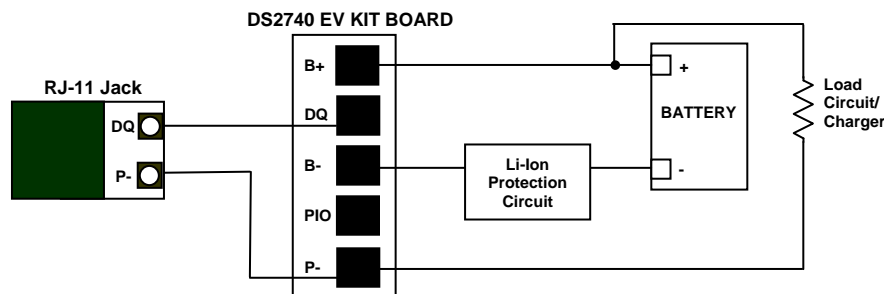

Software Installation

To install the DS2740 EV kit software, exit all programs currently running and download the latest DS2740 EV kit software from our website at www.maxim-ic.com. Unzip the compressed file and run SETUP.EXE to begin the installation process. Follow the prompts to complete the installation. The DS2740 EV kit software can be uninstalled in the *Add/Remove Programs* tool in the *Control Panel*. After the installation is complete, open the DS2740K folder and run DS2740K.EXE or select DS2740K from the program menu. A splash screen containing information about the evaluation kit appears as the program is being loaded.

All relevant data sheets and application notes on the DS2740 and DS2740 EV kit can be found on our website at www.maxim-ic.com.

Selecting the COM Port

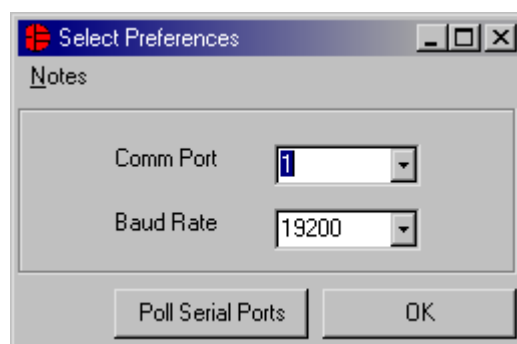

The first time the software runs, the *Port Settings* window appears. In this window, select the COM port to which the DS91230 is attached and the desired communication rate, then hit OK. The DS2740 EV kit software saves this COM port selection and automatically uses the selection each time the program starts. To change the COM port later, click the *Preferences* option on the menu bar, select *Edit Preferences*, and then select the appropriate port. To attempt to automatically locate the DS91230, click the *Poll Ports* button. Warning: automatically polling for the DS91230 can disrupt other devices connected to your computer's COM ports.

PROGRAM MENUS

Several pull-down menu options have been provided to simplify use of the DS2740 EV kit software for the user. Their functions are individually detailed below.

Registers Menu

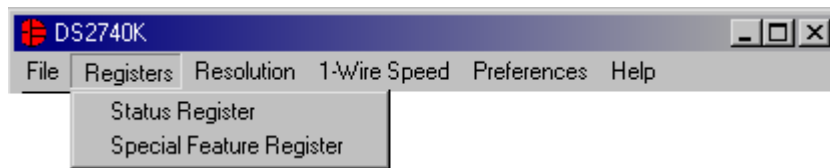

The *Registers Menu* gives immediate access to the *Status* and *Special Feature Registers* in the DS2740. Selecting one of the registers will open an individual control window giving the user a description of each register bit and the ability to read or write it. See the Status register window example in the next section. The individual control window can also be displayed by left clicking on any label referring to any of the bits of the *Status* or *Special Feature Registers*.

Status Register

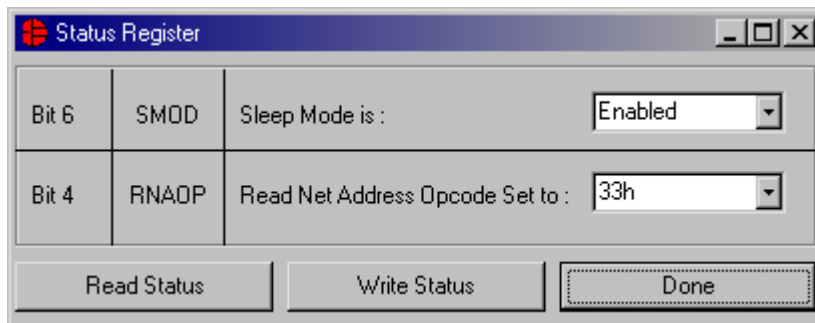

The present states of all register bits are displayed immediately upon opening the register window. Read/write locations contain a selection field to allow the user to determine their state.

Resolution Menu

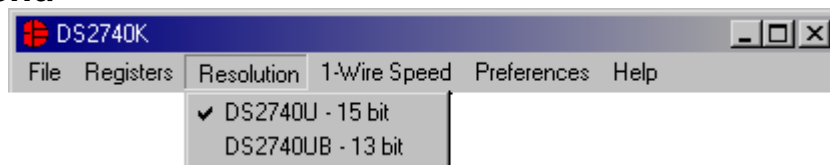

The *Resolution Menu* allows the user to select which version of the DS2740 is being used. This selection will affect the value of the units used to calculate the current. The software cannot detect which version of the DS2740 is being used, so if the wrong version is selected, the current reading will be off by a factor of 4.

1-Wire Speed Menu

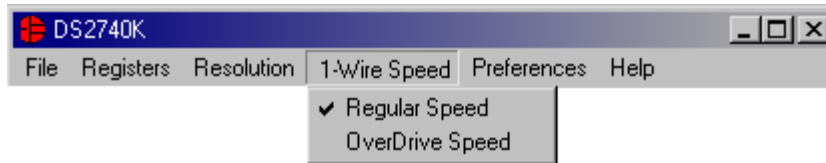

The *1-Wire*[®] *Speed Menu* allows the user to select with which 1-wire speed the device is set. The speed is determined by the state of the pin 1 (OVD pin). If pin 1 has a value of 1, the device communicates with 1-wire overdrive timing. If pin 1 has a value of 0, the device communicates with regular 1-Wire timing.

Preferences Menu

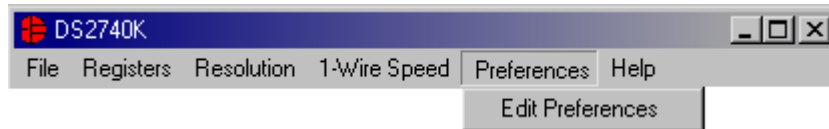

The *Preferences Menu* allows the user to change COM port settings at any time. *Edit Preferences* opens the *Select Preferences* window. See *Selecting the COM Port* above.

Help Menu

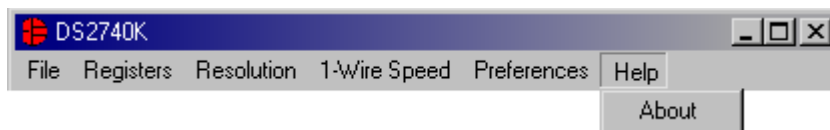

Selecting the *About* topic from the *Help Menu* will open a window containing information about this program and Dallas Semiconductor.

PROGRAM TABS

All functions of the program are divided under four tabs in the main program window. Left click on the appropriate tab to move to the desired function page. Located under the *Meters* tab is all information on real-time updates measured by the DS2740: current, accumulated charge, and the state of the SMOD, RNAOP and PIO bits of the *Status* and *Special Feature Registers*. The *Data Log* tab allows the user to store all real-time information to a file. The *Memory* tab displays the contents of every register and memory location inside the DS2740 and allows the user to alter the data. The *Pack Information* tab gives the user the ability to choose with which device on the 1-Wire bus to communicate and set the value of the sense resistor.

1-Wire is a registered trademark of Maxim Integrated Products, Inc.

Meters Tab

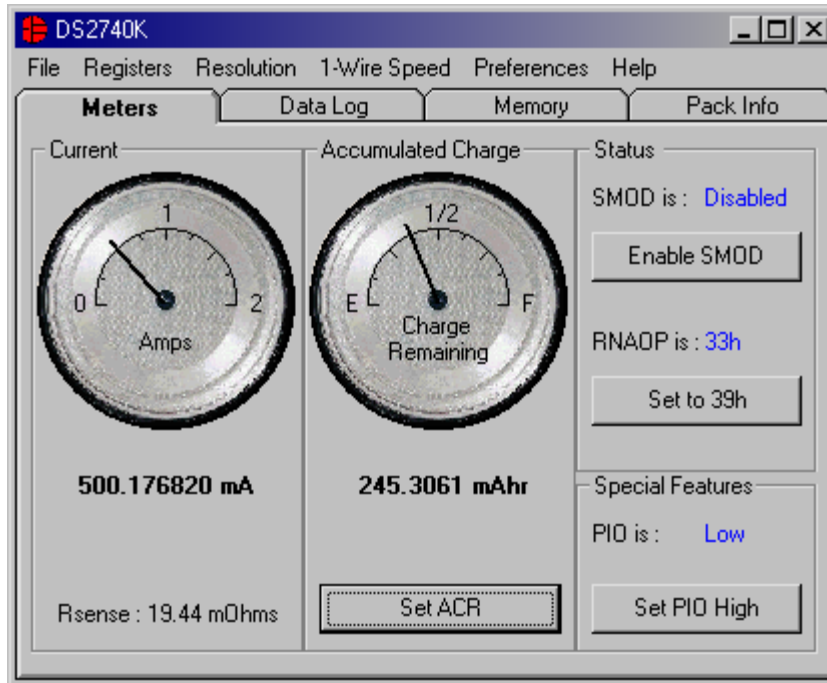

The *Meters Screen* displays the latest real-time measurements of current and accumulated charge with both analog meter readouts and digital values. The sense resistor value used to calculate the current reading is shown in the current section. Left click on it or go to the sense resistor sub-tab under *Pack Info* to change this value.

The values of the SMOD, RNAOP, and PIO bits of the *Status* and *Special Feature Registers* are also displayed. The user also has the ability to toggle the value of these bits by left clicking on the associated button.

Set Accumulated Current Register

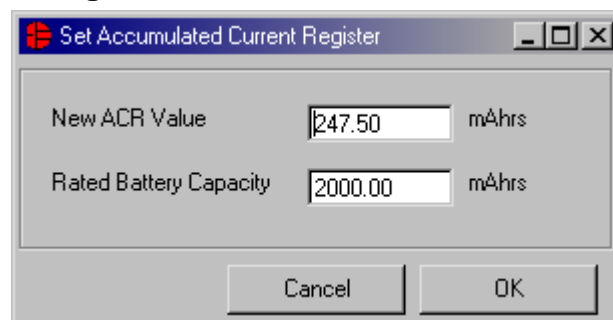

The user can bring up the *Set Accumulated Current Register* window by left clicking the *Set ACR* button. This window allows the user to enter values for the *Accumulated Current Register* and *Rated Battery Capacity* in mA. Clicking the *OK* button will write the *New ACR Value* to the *DS2740's Accumulated Current Register*. The *Rated Battery Capacity* is used to determine full-scale range on the *Accumulated Charge Meter* and is only a software value; it is not stored on the device.

Data Log Tab

Real-Time Graphs

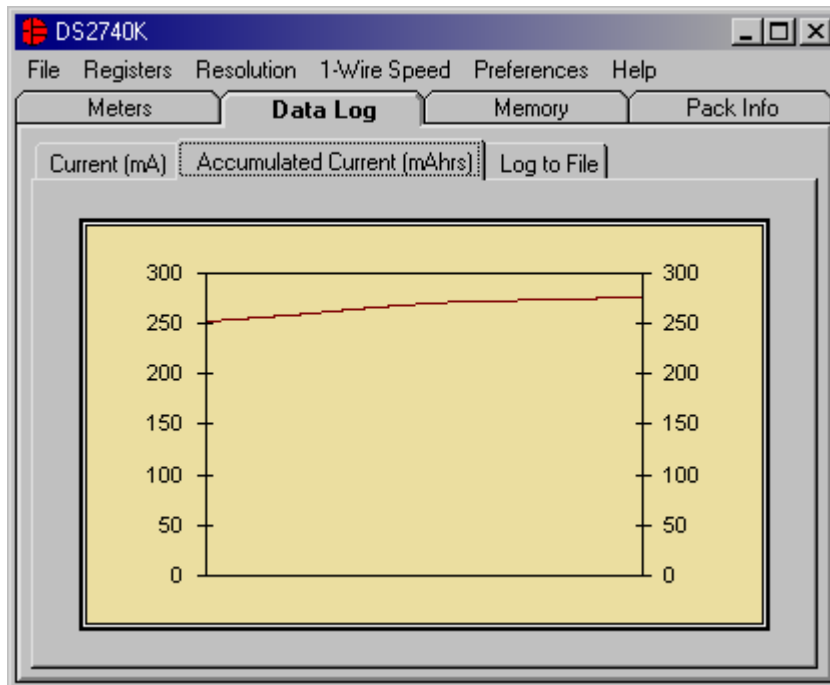

The *Data Log Tab* allows the user to see the DS2740's parameter measurements graphed over time. There are separate sub-tabs for current and accumulated current. Each graph displays the last 500 data points collected by the DS2740 EV kit software. The sampling interval can be adjusted using the menu located at the bottom of the window. The interval can be set from as slow as every 15 minutes to as fast as communication and the PC will allow. The *Clear Graphs* button will clear all data from both graphs, but does not reset the log to file function.

Log Data to File

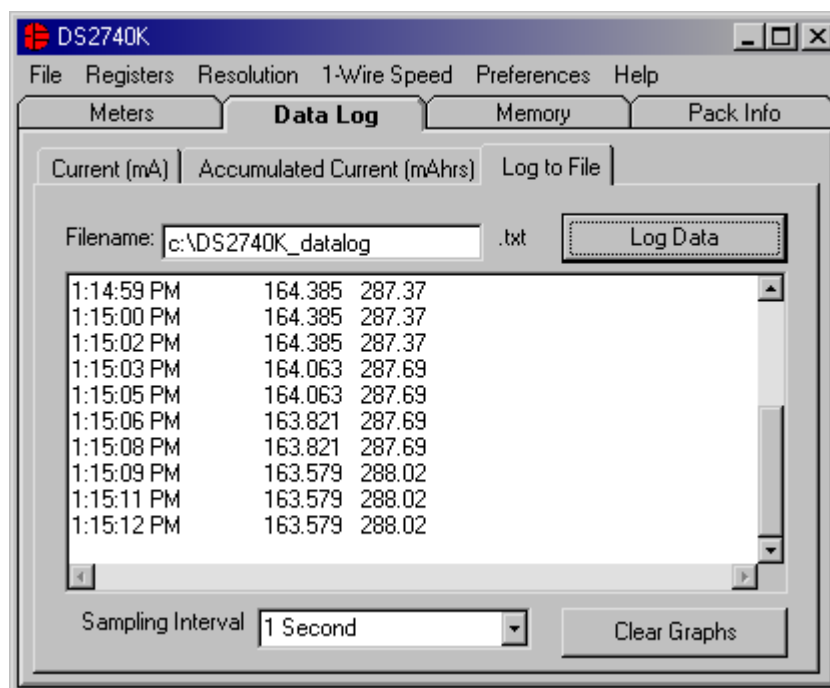

The *Log to File* sub-tab contains control information for storing all log data to an ASCII file. The default filename is c:\DS2740K_datalog.txt, but can be modified in the filename text field. The *Log Data* button toggles data logging off and on. Data will be stored at the same interval selected for updating the graphs in the tab-delimited format of:

“Time<tab>Current<tab> ACR”

for easy import into a spreadsheet. The 50 most recent samples are displayed in the window for observation. Warning: the *Log Data* function overwrites previous file information. To prevent the loss of data previously stored in the file, change the filename before clicking the *Log Data* button.

Memory Tab

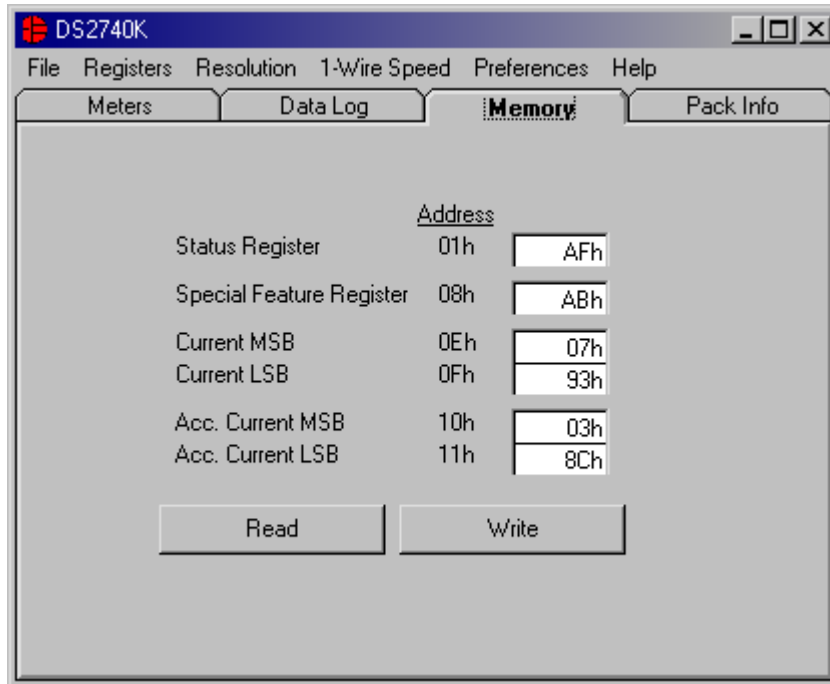

The *Memory Tab* gives the user access to all 6 user registers inside the DS2740. Most values can be modified by clicking in that address' text box and typing a new value in hexadecimal format. The *Current Register* and some bits in the *Status* and *Special Feature Registers* are read-only so they can not be modified by the user. The *Write* button will write all of the data locations displayed to the corresponding location inside the DS2740. The *Read* button will update the text boxes with data from the DS2740.

Pack Information Tab

Device Select

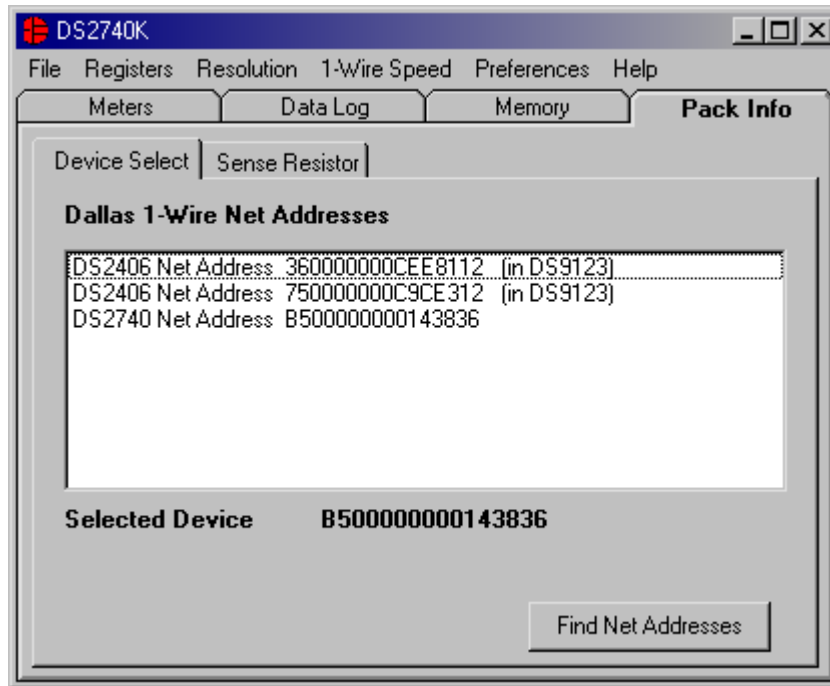

The *Device Select* sub-tab allows the user to choose with which device on the 1-Wire bus to communicate. Clicking on the *Find Net Addresses* button will begin a SEARCH NET ADDRESS operation on the 1-Wire bus. All 1-Wire devices found on the bus and communicating at the selected 1-Wire speed will be listed in the *Net Addresses* field. To communicate to any device on the bus, click on its address inside the *Net Addresses* field to select it. The program will now use this device for all operations (communicating using the *Match Net Address* command) until a different DS2740 is chosen.

Sense Resistor

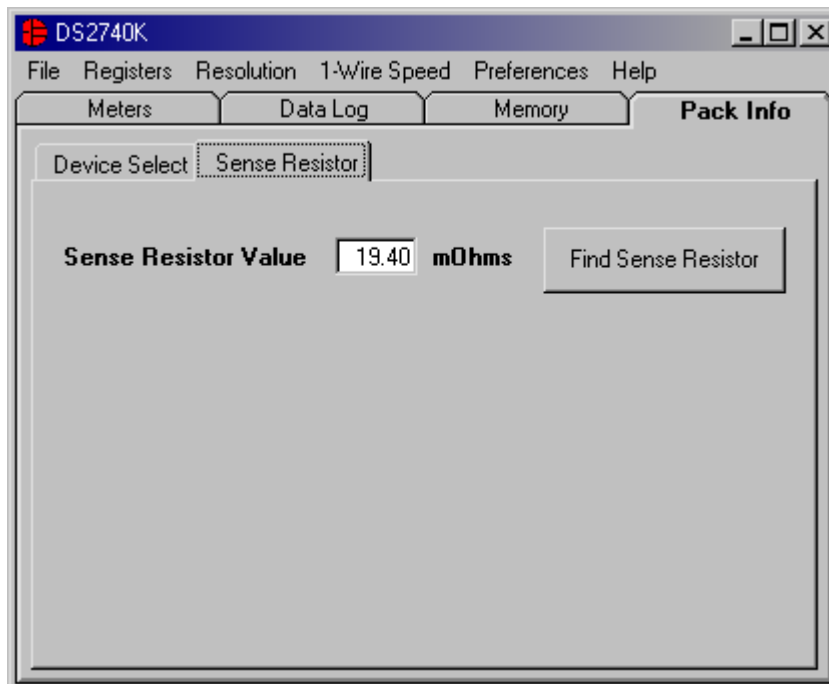

The *Sense Resistor* sub-tab allows the user to more accurately measure the current by entering the exact value of the sense resistor that is used. Enter the value of the resistor in $m\Omega$ s in the *Sense Resistor Value* field. This value will be used in software to calculate the current flowing through the sense resistor.

Find Sense Resistor

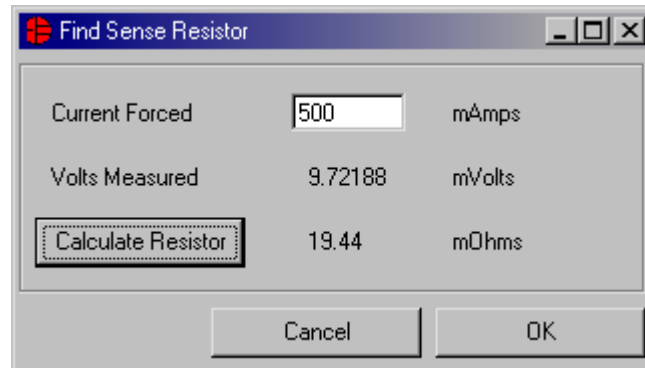

The *Find Sense Resistor* button opens the *Find Sense Resistor* window. The user can then determine the resistance by forcing a known current and measuring the voltage drop with the DS2740. The program uses this value to convert the voltage difference from the SNS and VSS pins into mAmps. If this value does not match the value of the external resistor, current measurements will be inaccurate. If the value is 0 the program automatically defaults to a resistor of $20m\Omega$ s. This is a software value only, it is not stored on the DS2740.

DS2740 EV Kit Schematic

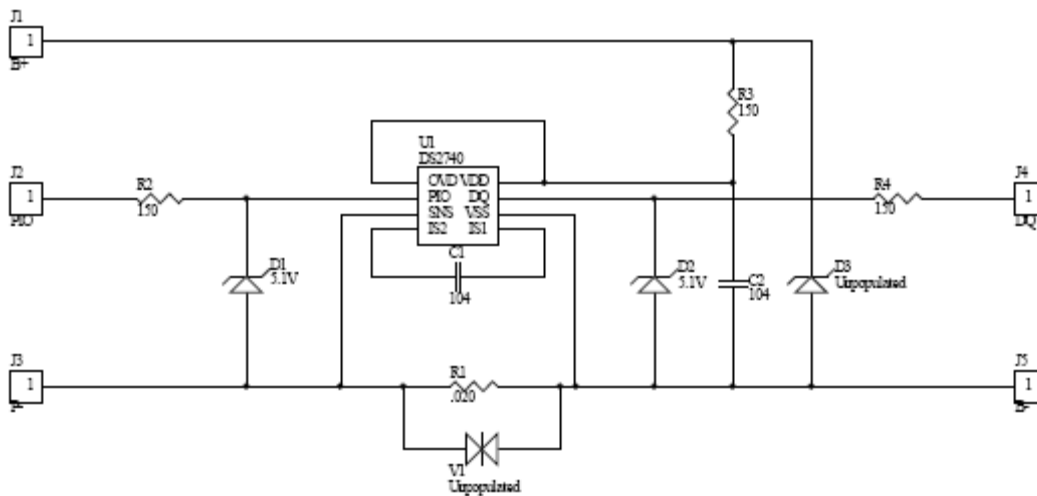

REVISION HISTORY

REVISION NUMBER	REVISION DATE	DESCRIPTION	PAGES CHANGED
0	4/03	Initial release.	—
1	10/09	Changed the part number from DS2740K to DS2740EVKIT.	All