

This document, including the design, configuration and mechanical features revealed herein are the sole, confidential and proprietary property of TRU Corporation. Reproduction or use thereof, in whole or part, is prohibited without the prior written consent of TRU Corporation.

REV.	DESCRIPTION	DATE	APPROVED
-	ORIGINAL ISSUE	09/18/08	AM

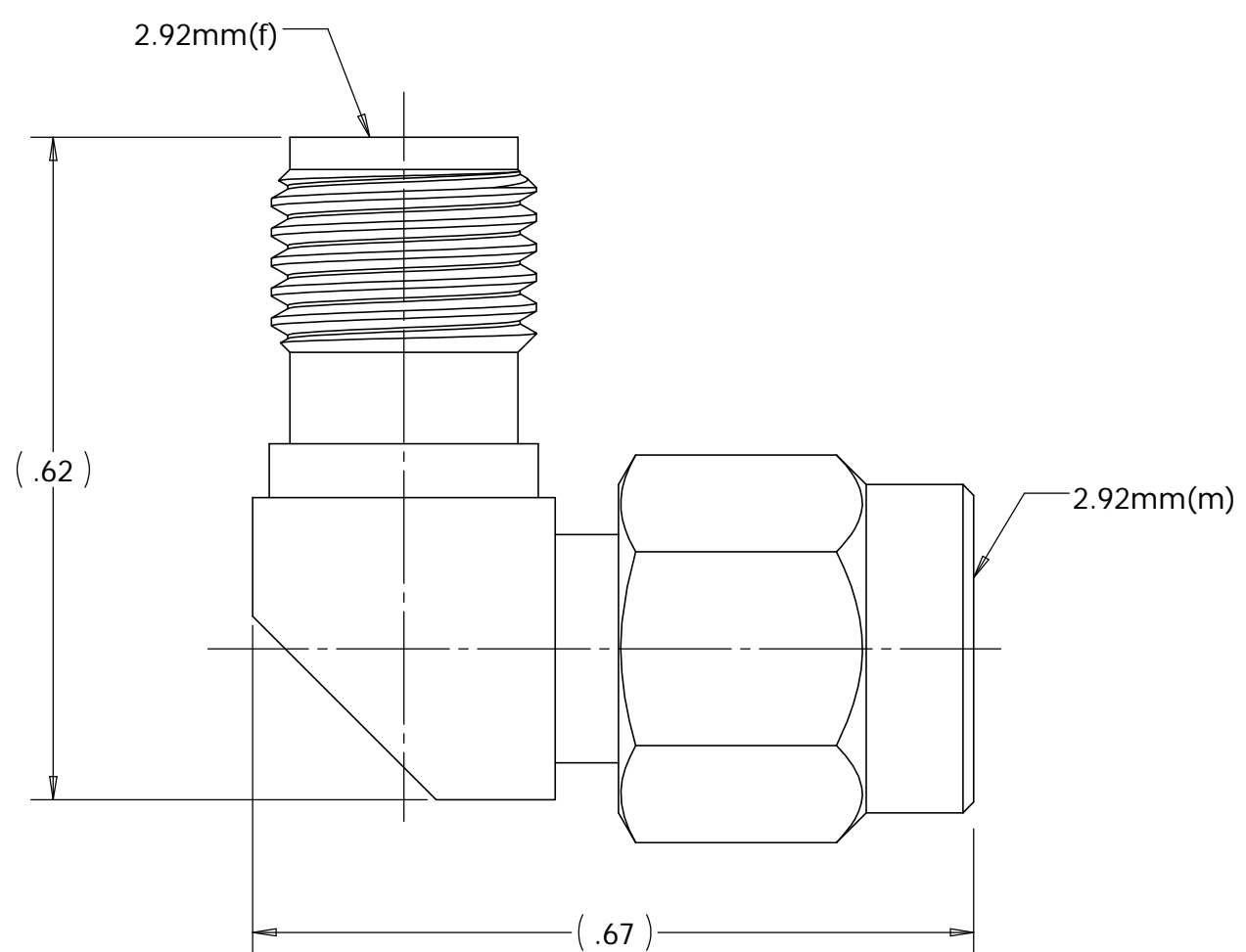

ENGINEERING DATA

ELECTRICAL:

FREQUENCY RANGE: DC to 40GHz
 VSWR MAX: 1.40:1

INSERTION LOSS MAX: $.06x\sqrt{\text{FREQ (GHz)}}$

MECHANICAL:

INTERFACE PER IEEE 287

MATERIAL:

BODIES & COUPLING NUT: STAINLESS STEEL
 CONTACTS: BERYLLIUM COPPER
 SUPPORT BEAD: PPO OR EQUIVALENT

FINISH:

BODIES & COUPLING NUT: PASSIVATED
 CONTACTS: GOLD PLATED

NOTES:

- ALL DIMENSIONS SHOWN ARE REFERENCE ONLY.

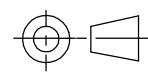
MATERIAL	DO NOT SCALE DRAWING	DRAWN AM	DATE 09/12/08	 TRU CORPORATION 245 LYNNFIELD STREET, PEABODY, MA 01960 The Custom Interconnect Leader™
	UNLESS OTHERWISE SPECIFIED: DIMENSIONS ARE IN INCHES	ENG APPR. AM	DATE 09/15/08	
COMMENTS:	TOLERANCES: FRACTIONS: $\pm 1/64$.XX : $\pm .01$.XXX : $\pm .005$ ANGLES: $\pm 1/2^\circ$ MACHINED SURFACES: $63/\sqrt{\quad}$	MFG APPR.	DATE	TITLE: 2.92mm(f) to 2.92mm(m) R/A ADAPTER
		OTHER APPR.	DATE	
surface area: sq inch	weight: lbs	THIRD ANGLE PROJECTION 		SIZE B
		DWG. NO. TRU-11223-RA		REV -
		CAGE CODE: 92180		SCALE: 6:1
				SHEET 1 OF 1